

AC 2010-1595: A HIGH-PERFORMANCE WIRELESS REFLECTANCE PULSE OXIMETER FOR PHOTO-PLETHYSMOGRAM ACQUISITION AND ANALYSIS IN THE CLASSROOM

Kejia Li, Kansas State University

Kejia Li received his B.S. degree in Electronic and Information Technology and Instrumentation from Zhejiang University, China, in 2008. He is currently pursuing the M.S. degree in Electrical & Computer Engineering at Kansas State University. He works as a Research Assistant in Medical Component Design Laboratory with research interests in embedded system design, digital signal processing, and hemodynamics.

Steve Warren, Kansas State University

Steve Warren received a B.S. and M.S. in Electrical Engineering from Kansas State University in 1989 and 1991, respectively, followed by a Ph.D. in Electrical Engineering from The University of Texas at Austin in 1994. Dr. Warren is an Associate Professor in the Department of Electrical & Computer Engineering at Kansas State University. Prior to joining KSU in August 1999, Dr. Warren was a Principal Member of the Technical Staff at Sandia National Laboratories in Albuquerque, NM. He directs the KSU Medical Component Design Laboratory, a facility supported by the National Science Foundation that provides resources for the research and development of distributed medical monitoring technologies and learning tools that utilize biomedical contexts. His research focuses on (1) plug-and-play, point-of-care medical monitoring systems that utilize interoperability standards, (2) wearable sensors and signal processing techniques for the determination of human and animal physiological status, and (3) educational tools and techniques that maximize learning and student interest. Dr. Warren is a member of the American Society for Engineering Education and the Institute of Electrical and Electronics Engineers.

A High-Performance Wireless Reflectance Pulse Oximeter for Photo-Plethysmogram Acquisition and Analysis in the Classroom

Abstract

Pulse oximetry is an essential health-monitoring technique in both clinical and home care environments. From an engineering education perspective, pulse oximeter technology offers excellent study material in areas such as light-based sensor construction, embedded system design, control theory, and digital signal processing. However, off-the-shelf pulse oximeters do not provide suitable educational platforms for several reasons: (a) their design layouts and internal data flows are inaccessible to the user, (b) units that display photo-plethysmographic/pulse waveforms or make those signals available to the user provide data that have already been filtered in an unspecified manner, and (c) sensor sites are usually constrained to fingertips, ear lobes, or other locations for which commercial transmittance probes are already constructed.

This paper presents the novel design and initial application of a high-performance, wireless reflectance pulse oximeter that exhibits a filter-free design and offers full access to relevant waveform data. A unique embedded control system extracts the DC (baseline) and AC (time-varying) signal components from the original reflectance signal without the use of any analog filter circuitry, ensuring high-fidelity pulsatile waveforms that can offer several thousand peak-to-valley digitization levels. All red and near-infrared signal data can be stored on the unit or transmitted in real-time to a personal computer via a wireless ZigBee or wired USB link mapped to a serial port. Sampling frequencies of 240 Hz or higher can be easily realized for all waveform channels simultaneously, so all signal information is retained, and ambient noise (e.g., 120 Hz flicker from room lights) is unaliased. These data are logged and displayed graphically by a MATLAB interface, which also incorporates a communication control panel and a set of pre-defined signal processing modules for signal compensation, real-time filtering, fast Fourier transformation, and oxygen saturation level calculation.

The pulse oximeter and MATLAB interface were initially employed in a Fall 2009 biomedical instrumentation laboratory. For this laboratory, students viewed photo-plethysmograms from various body locations, applied linear-phase filters for artifact removal, and determined cardiovascular parameters such as respiration rate, reflection index, and stiffness index. Overall, the students' experience was highly positive, and all of the formal learning objectives were successfully addressed.

I. Introduction

A pulse oximeter is a medical device that can non-invasively yield cardiopulmonary data that are useful in both clinical and ambulatory care environments.¹ Photo-plethysmograms obtained by the optical sensing circuitry in a pulse oximeter provide information similar to that offered by an electrocardiogram² (e.g., pulse rate and respiration rate³) but can also be used to determine arterial blood oxygen saturation, blood pressure,⁴ and other vascular parameters.^{5,6} For example, a reflection index correlates to endothelial function,⁵ and a stiffness index can provide an arterial stiffness measure that relates to pulse wave velocity.⁶

According to the World Health Organization, cardiovascular disease (CVD) is the leading cause of mortality in the developed world,⁷ so the development of pulse oximeters which offer high-fidelity photo-plethysmographic data that can facilitate early detection of CVD is an important step towards the creation of effective CVD-prevention therapies. From an engineering education perspective, pulse oximeter technology offers excellent study material in areas such as light-based sensor construction, embedded system design, control theory, and digital signal processing.

This paper presents a new high-performance, wireless reflectance pulse oximeter and a corresponding MATLAB interface that were utilized in a Fall 2009 biomedical instrumentation course. Section *II. Background* provides an overview of the pulse oximeter hardware/software and introduces a new classroom application for photo-plethysmographic analysis. Section *III. Methods*, lays out the classroom laboratory experience and the associated self-assessment approach. Results from the laboratory experience and the assessment surveys are summarized in Section *IV. Results and Discussion*.

II. Background

A. Circuit- and System-Level Elements of a Novel Pulse Oximeter

The wireless reflectance pulse oximeter presented here⁸ is a successor to the modules developed in 2006⁹ and 2002¹⁰ in Kansas State University's Medical Component Design Laboratory. In the *Future Work* section of the paper that described the 2006 module,⁹ the authors noted that a wireless link would be a helpful upgrade that would require a battery pack, a wireless protocol stack, and consequently a larger device. After comparing the specifications of six common wireless medical networks,¹¹ the authors chose IEEE 802.15.4 for this new pulse oximeter design because of its low power consumption, adequate data rate, and suitable transmission range. Off-the-shelf development toolkits are also widely available for this standard. Finally, numerous mesh network topologies already exist that can utilize IEEE 802.15.4, including ZigBee and 6LoWPAN, which enables efficient IPv6 communication.¹² ZigBee is employed in the pulse oximeter design discussed here. The upgrades and features incorporated in this newer design are not limited to the ZigBee wireless link. They include

- a robust and powerful microprocessor with a 16 MHz 32-bit RISC CPU,
- a high speed, precision analog-to-digital converter (ADC) and digital-to-analog converter (DAC),
- an optimized radial sensor geometry that incorporates a cost-effective, bi-color light-emitting diode (LED) excitation source surrounded by large-area photodiodes (detectors),
- a unique filter-free control system to achieve high fidelity photo-plethysmographic signals that can offer thousands of peak-to-valley digitization levels,
- flash memory for local storage in the absence of a wireless connection,
- a USB-based battery charging system.
- a novel firmware design, and
- a MATLAB interface to control data acquisition settings and facilitate post processing.

Detailed technical information for this pulse oximeter is contained in a separate paper.⁸ Figure 1 depicts the physical unit, which has dimensions of 41 mm by 36 mm (excluding the antenna

board). The double-sided device incorporates a microprocessor with an integrated ADC, DAC, and IEEE 802.15.4 wireless module as well as a bi-color excitation LED (SMT 660/910), detection circuitry (photodiodes and their operational amplifiers), and a power management system (battery, charger chip, and USB bridge chip).

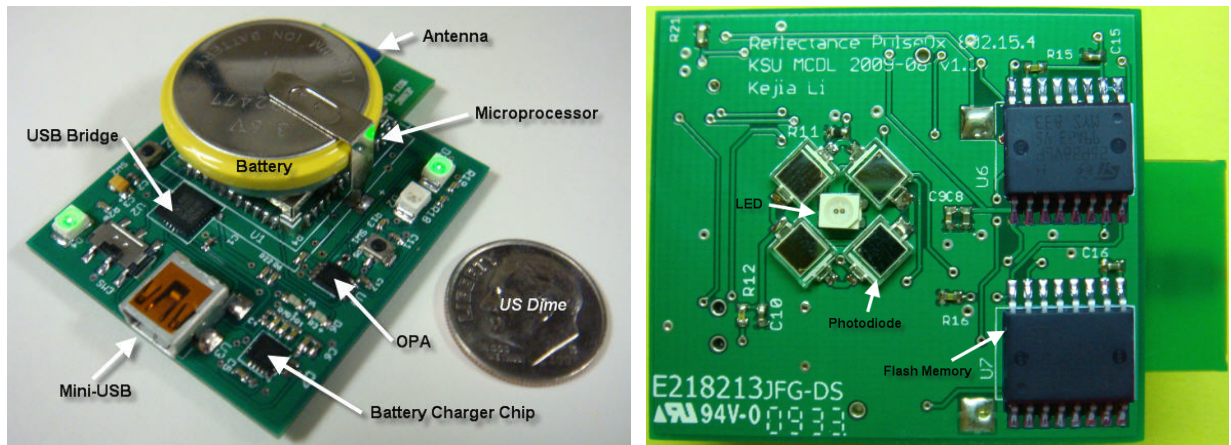

Figure 1. Top (left) and bottom (right) views of the wireless reflectance pulse oximeter.⁸

Figure 2 shows a functional depiction of the system. The tissue is excited by the LEDs under the control of the DAC and the digital input/output (DIO) port, which contributes to the realization of adaptive LED intensity functionality. I.e., given a low-quality signal from a poorly perfused subject, the control system raises the LED current to provide more excitation light, and vice versa. The AC signal extraction process and signal sampling are coordinated by another DAC, two ADCs, and an operational amplifier unit, where the DAC outputs a baseline (reference) voltage estimated from a time-windowed segment of the detector signal.⁸

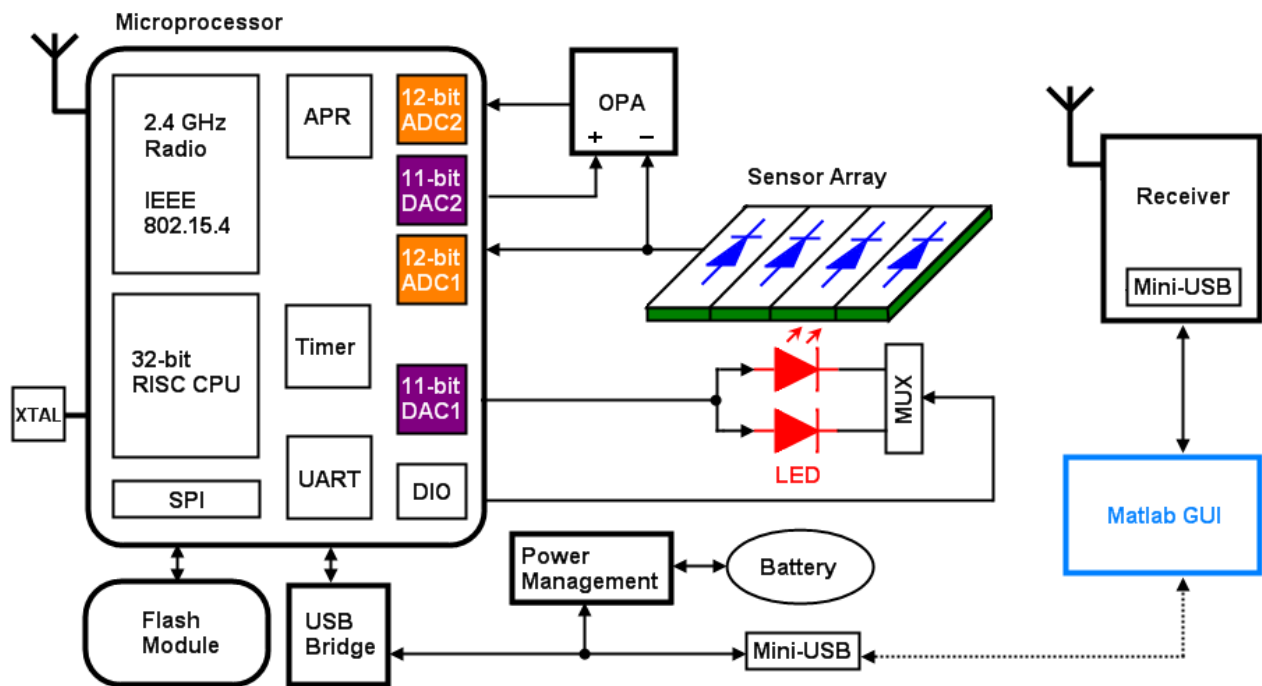

Figure 2. Functional layout for the new pulse oximeter.⁸

Lowpass and highpass filters are usually employed by pulse oximeter designers to extract the photo-plethysmographic signals and to eliminate noise, such as in the MIT ring sensor design.¹³ However, filters can distort signals and remove information that would otherwise be useful for further hemodynamic assessments. The filter-free design of this module ensures high signal quality, and the high sampling frequency (a default of 240 Hz) prevents frequency aliasing of the majority of the ambient noise in the local monitoring environment.

B. MATLAB Acquisition and Post-Processing Interface

A MATLAB interface (see Figure 3) allows a user to set/view communication parameters, visualize photo-plethysmographic data, process these data in real time, and log raw data to files.

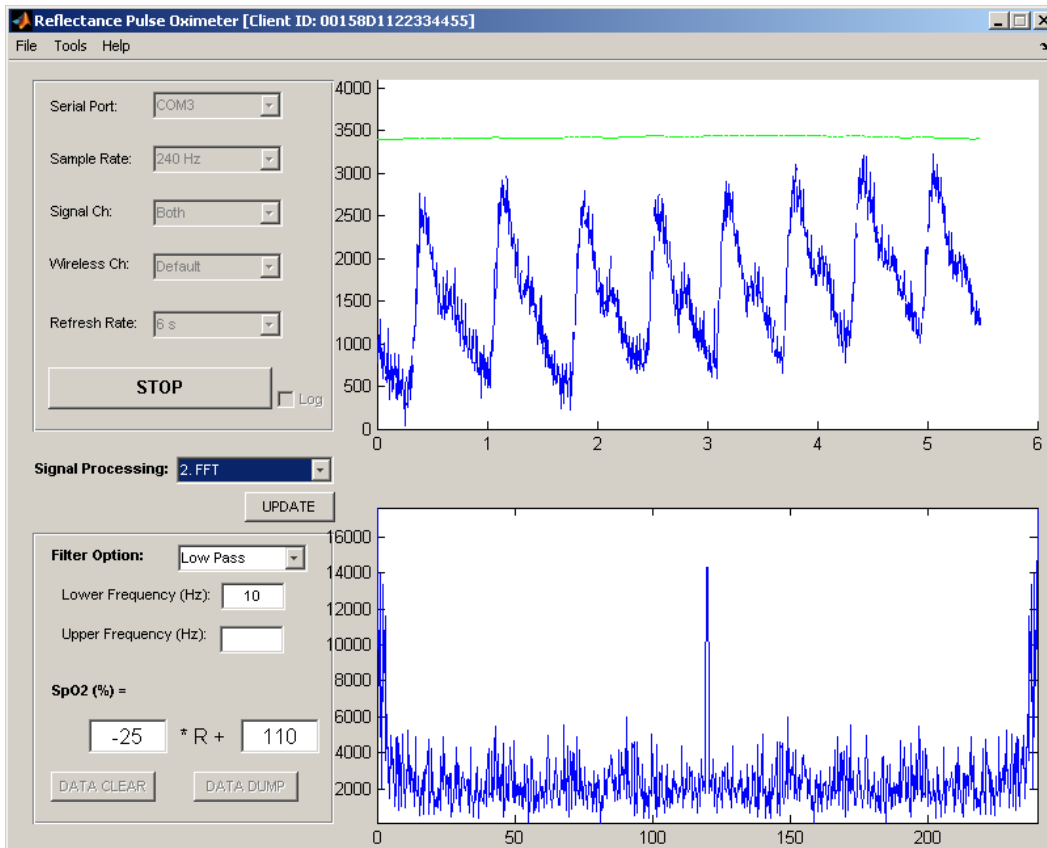

Figure 3. MATLAB interface for the pulse oximeter. In this example, a Fast Fourier Transform (FFT) operation is applied to the current data segment.

C. Digital Volume Pulse (DVP) Analysis

Digital volume pulse (DVP) analysis, a technique utilized in the laboratory experience described in Section III. *Methods*, is a new addition to KSU pulse oximetry laboratories that utilize custom pulse oximeter designs.^{9,10} DVP analysis utilizes a representative cycle of a photo-plethysmogram obtained from the fingertip. Figure 4 illustrates an individual cycle of the waveform, where the systolic (or direct) component with height “b” results from the direct transmission of the systolic pressure wave from the aorta to the fingertip. The diastolic (or

reflected) component with height “a” results from a reflection of the pressure wave from the peripheral arteries to the aorta and then back to the fingertip. The relative height of the diastolic component depends on the tone of the small peripheral arteries; greater elasticity will induce a larger secondary hump. The reflection index (RI) is the relative measure of the height of the diastolic component compared to the height of the systolic component:

$$RI_{DVP} = \frac{a}{b} \times 100\% \quad (1)$$

The peak-to-peak time (PPT) depends on the pulse wave velocity (PWV) in the aorta and the large arteries; the PWV increases with increased arterial stiffness. The stiffness index (SI) that correlates well with the aortic PWV⁶ and is of similar magnitude to that of the PWV⁷ is the measure of the subject height divided by the PPT:

$$SI_{DVP} = \frac{\text{Subject_Height}}{PPT} \quad (2)$$

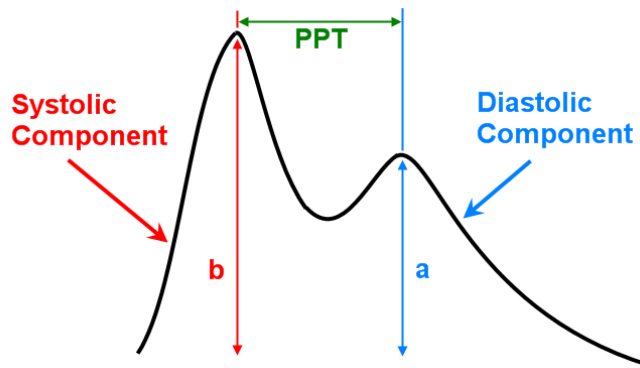

Figure 4. Digital volume pulse analysis.

III. Methods

A. Laboratory Experience with the New Pulse Oximeter

The new wireless pulse oximeter design and its accompanying MATLAB interface were initially applied within the context of a Fall 2009 Biomedical Instrumentation course jointly taught by faculty in the KSU Department of Electrical & Computer Engineering (College of Engineering) and the KSU Department of Anatomy & Physiology (College of Veterinary Medicine). Ten undergraduate and graduate students were enrolled in this course. Ten sets of devices were manufactured, programmed, and tested; the instructors let the students work in pairs (five groups of two students). A commercial pulse oximeter (Smiths Medical BCI[®] 3180) was employed as a comparison standard for the blood oxygen saturation values calculated by the custom system. In terms of *learning objectives*, the instructors anticipated that *each student should be able to do the following upon completion of the laboratory*:

- Explain the physiologic origin of a transmittance/reflectance photo-plethysmogram
- Describe the hardware and software components required to determine blood oxygen saturation using light-based sensors
- Calculate blood oxygen saturation given a set of red/infrared plethysmograms
- Assess the character and spectral content of these time-varying signals
- Extract physiologic data from a photo-plethysmogram

- Describe person-to-person variations in plethysmographic data
- Calculate calibration coefficients using different approaches
- Extract cardiovascular parameters such as respiration rate and peak-to-peak time from the photo-plethysmographic waveform
- Counteract the effects of mild motion artifact

These learning objectives were supported by required background reading (lecture notes) and the following step-by-step laboratory protocols:

1. Module setup (driver installation and serial port allocation) and MATLAB interface configuration (sampling rate, signal channel, wireless channel, etc.).
2. Initial acquisition of fingertip photo-plethysmograms to identify ambient light and motion artifact in a set of scenarios (covered sensor, uncovered sensor, slight motion, etc.).
3. Recording of 40 seconds of quality photo-plethysmographic data with a stable baseline, high peak-to-valley values, and a non-saturated AC component. This included the calculation of the calibration ratio, $R = \{I_{ac}/I_{dc}\}_{red}/\{I_{ac}/I_{dc}\}_{ir}$, which was updated every 0.5 seconds using the Fourier transform method^{14, 15} applied to the previous 4 seconds of data.
4. Calculation of the blood oxygen saturation level by plugging the R array into a published calibration curve ($SpO_2 = -25R + 110$ ¹⁶) or the module's own experimental calibration curve ($SpO_2 = -23.7R + 109.2$ ⁸). These results and their mean/median values were compared to blood oxygen saturation values reported by the BCI 3180 pulse oximeter.
5. Acquisition of another 40 seconds of quality photo-plethysmographic data from the other group member and a qualitative comparison of these signals and oxygen saturation levels.
6. Measurements at the palm, wrist, ear lobe, and temple to perceive variations in the shape of the plethysmogram at body locations with differing vascular profiles.
7. Recording of 120 seconds of photo-plethysmographic data from the temple while counting the number of respiration cycles. This was accompanied by a thought exercise related to the extraction of respiration rate from a photo-plethysmogram.
8. Extraction of cardiovascular parameters from several consecutive cycles of a fingertip photo-plethysmogram acquired with the infrared channel, which should have a better signal-to-noise ratio than the red channel. Given a notch or inflection point on the down slope of every cycle, Equations 1 and 2 were then be used to calculate the corresponding reflectance index (RI) and stiffness index (SI) indicated during each cycle.

Reference algorithms for photo-plethysmogram analysis were provided to students in the form of MATLAB M-files (`loadme_spo2.m` for protocol steps 3-5, `loadme_resp.m` for step 7, and `loadme_dvp.m` for step 8).

B. Learning Self-Assessment Survey

A laboratory assessment was performed by processing survey feedback from all ten students. The survey consisted of two elements: (a) students' perceptions of their own learning given the stated learning objectives and (b) students' impressions of the overall experience. The results are tallied and discussed in the following section.

IV. Results and Discussion

A. Pulse Oximeter Performance and Student Practice

The new pulse oximeter design exceeded expectations in this initial laboratory experience. Due to the adaptive-LED-intensity mechanism (which seeks to optimize signal quality independent of a subject's relative perfusion), all ten students acquired high-quality photo-plethysmographic data and derived meaningful analysis results, which has not always been the case with previous pulse oximeter designs.^{9,10} Figure 5 shows a team of students acquiring fingertip data with a goal to identify the ambient noise component. By applying an FFT operation to the current data segment, they found a 120 Hz spike in the frequency domain, where the spike is caused by 120 Hz flicker from the full-wave-rectified fluorescent room lights. Figure 6 illustrates the use of the BCI[®] 3180 pulse oximeter (left) and temple-based measurements for the determination of respiration rate (right).



Figure 5. Photo-plethysmogram acquisition from the fingertip and ambient noise analysis.



Figure 6. Blood oxygen saturation determination using the BCI[®] 3180 pulse oximeter (left) and photo-plethysmogram measurement on the temple to assess respiration rate (right).

Photo-plethysmogram acquisition at the wrist can be a challenge with a reflectance pulse oximeter since perfusion is relatively low in the tissue surrounding the radial and ulnar arteries. Attaining a high quality waveform can require the application of pressure to the device in order to give the optical sensor access to the relatively deep major arteries.^{9, 17} The large area photodiodes used in this new reflectance sensor help significantly, as illustrated in Figure 7, which contains a wrist photo-plethysmogram (blue curve) that demonstrates up to 3000 digitization levels from peak to valley. To demonstrate the effectiveness and flexibility of the MATLAB interface, Figure 7 also displays a filtered version of the signal, where the filter is a 200-order, linear phase lowpass filter with a cutoff frequency of 10 Hz. Note the absence of noise in the signal and the time delay of 414 ms imposed by the filter. Using the pulse oximeter, students were able to obtain high quality waveforms from many other locations, including the palm, forehead, and ear lobe.

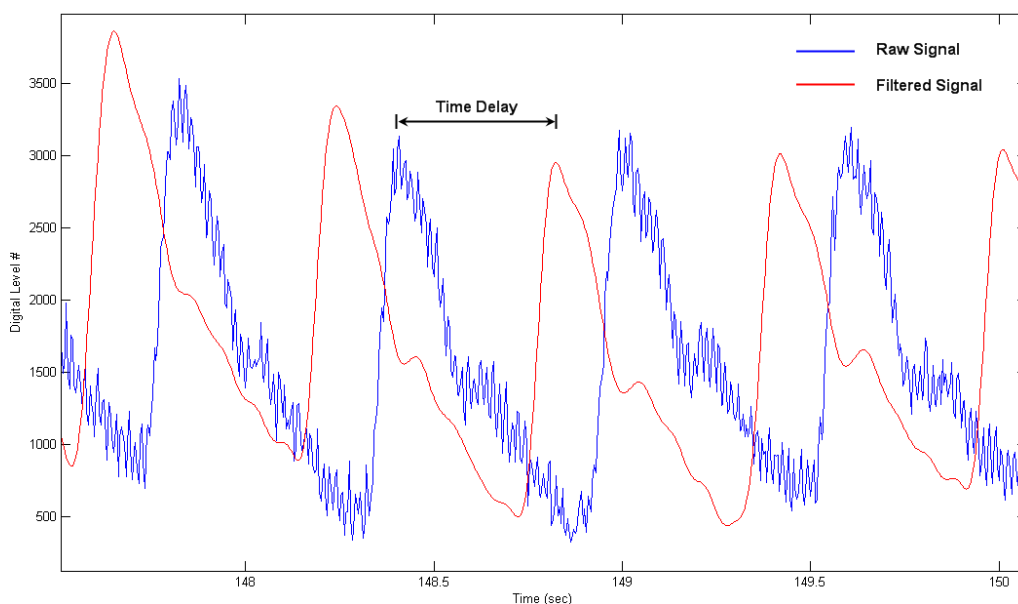

Figure 7. Wrist photo-plethysmogram (blue) and the filtered, noise-free signal (red).

DVP analyses were also successful. As an example, one group calculated the following cardiovascular parameters: $b = 971$ digital levels, $a = 694$ digital levels, $PPT = 0.17$ sec, $RI = 71.4\%$ and $SI = 10.5$ m/s.

B. Student Survey Results and Laboratory Assessment

The first survey element addressed the laboratory learning objectives, evaluating students' self-perceived abilities with respect to each objective both before and after the laboratory experience. Table 1 compiles the results for this survey element, where the “○” and “●” columns represent the average of the ten students' perceived levels of comfort and proficiency before and after the laboratory, respectively. The “▲” column represents average improvement for each objective.

The overall self-perceived improvement in ability is apparent as noted in the “▲” column, where the average improvement is 2.0 out of 5, or a “qualitative” 40% improvement compared to their perceived ability prior to the laboratory. While the variation in the average improvement is

relatively small (a range of ± 0.3), a couple of ideas surface. First, the most improvement is perceived for objectives where students were asked to *do* something specific (Obj. 3 – Calculate SpO₂; Obj. 5 – Extract data; Obj. 9 – Extract cardiovascular parameters). The least improvement relates to objectives that are more vague (Obj. 2 – Describe ...; Obj. 6 – Describe ...), objectives where tasks were performed for the students by software already provided by the instructor (Obj. 7 – Calculate calibration coefficients ...), or objectives that were not emphasized as much as previously planned (Obj. 8 – Counteract the effects ...). When asked, “Do any other ‘learned objectives’ stand out as skills or abilities that you now possess based upon your pulse oximetry laboratory experience?” one student responded, “I know better how different artifacts are introduced into the signal.”

Table 1. Learning Objectives Survey Results

On a scale of 1 to 5, note your level of ability with respect to the following learning objectives both before and after the laboratory experience, where “1” means no ability/understanding and “5” means high confidence.

Learning Objectives	○	●	▲
Explain the physiological origin of a transmittance/reflectance photo-plethysmogram	2.1	4.1	2.0
Describe the hardware and software components required to determine blood oxygen saturation using light-based sensors	1.9	3.8	1.9
Calculate blood oxygen saturation (SpO ₂) given a set of red/infrared plethysmograms	1.5	3.7	2.2
Assess the character and spectral content of these time-varying signals	2.1	4.1	2.0
Extract physiologic data from a photo-plethysmograph	1.8	4.1	2.3
Describe person-to-person variations in plethysmographic signal data	2.1	4.0	1.9
Calculate calibration coefficients using different approaches	1.8	3.5	1.7
Counteract the effects of mild motion artifact	1.7	3.5	1.8
Extract cardiovascular parameters such as respiration rate and peak-to-peak time (PPT)	2.2	4.4	2.2
<i>Average</i>	1.9	3.9	2.0

The second survey element (“Materials and Protocols”), evaluated students’ impressions of the overall laboratory experience. These results are tallied in Table 2. In Table 2, the “Impression” column presents the average satisfaction score for the ten students. The “Comment” column is a terse aggregation of the student feedback. E.g., a protective case is recommended by one student (area 1), and some students noted the driver setup was troublesome (area 5). Based upon the responses to areas 6 (“B. First Trial ...”) and 10 (“F. Digital Volume ...”), the instructors need to spend more time prior to the laboratory discussing the theoretical underpinnings of these signals and the related processing approaches.

Overall, most of the comments were positive, and when asked, “Do you have any other overall impressions or comments that you wish to share?” most of the students responded that they were impressed by the new pulse oximeter module and found the laboratory to be enjoyable:

- Student A: “It was overall an enjoyable and informative experience.”
- Student B: “Impressive with both the device and the MATLAB script, especially the usability of the MATLAB interface.”
- Student C: “The pulse oximeter was very easy to use and set up as well as the interface.”
- Student D: “It was a fun lab, and the device was very impressive. It was fun to test the device in different environments to see the response.”
- Student E: “Fairly interesting. The device seems to work effectively without any trouble. It doesn’t seem really expensive to build, though it’s fairly sophisticated.”

Table 2. Materials and Protocols Survey Results

On a scale of 1 to 5, note your impressions of the overall experience in the following areas, including laboratory protocols A-F, where a “1” denotes a dislike for the individual experience and a “5” denotes enjoyment. Feel free to comment on a given item.

Materials and Protocols	Impression	Comment
Appearance and usability of the wireless pulse ox module	4.6	Really interesting. Stability issue. Case. Easy to use. Worked well.
Signal visualization and processing with the MATLAB GUI	4.8	Easy to use. Very impressive. Tricky.
MATLAB scripts for signal plots, calculations, and etc.	4.6	
Help from the instructor and laboratory assistant	5.0	Mostly aware of what’s going on ...
A. Module Setup	4.0	Driver setup was confusing. Not the plug-and-play type.
B. First Trial and Signal Observation	3.9	Tough to know what signal meant at first.
C. Measurement on the Fingertip and Oxygen Saturation Calculation	4.5	Able to get a good signal. Pretty accurate and fairly straight forward.
D. Person-to-Person Variations	4.3	Cool to see. Very Apparent. Could see variations but maybe noise. My signal was poor.
E. Measurement on the Temple and Respiration Rate	4.5	Fun.
F. Digital Volume Pulse Analysis	3.7	

V. Conclusion

A high-performance, wireless reflectance pulse oximeter was designed for applications in research and education. When compared to conventional pulse oximeters that also provide photo-plethysmograms, it features (1) a filter-free signal extraction design that prevents signal distortion and retains signal information that is often discarded and (2) adaptive LED intensity functionality that optimizes the opportunity to acquire a high-quality signal from individuals with low peripheral perfusion. Additionally, it offers full access to high-data-rate signals in an open control system and is bundled with a user friendly MATLAB interface for data visualization, processing, and storage.

A Fall 2009 Pulse Oximetry laboratory in a Biomedical Instrumentation course provided the initial venue for student/device interactions. All ten students that participated managed to acquire quality data sets and use them for further analyses. According to student survey feedback, all participants were impressed by the new pulse oximeter module and found the laboratory to be enjoyable and informative. The survey-based laboratory assessment indicated a 40% qualitative improvement in students’ self-perceptions of their abilities relative to the learning objectives for the laboratory.

References

- [1] S. Warren, J. Yao, and G. E. Barnes, "Wearable Sensors and Component-Based Design for Home Health Care," in *2nd Joint EMBS-BMES Conference*, Houston, TX, Oct. 23-26, 2002, pp. 1871-1872
- [2] M. J. Drinnan, J. Allen, and A. Murray, "Relation between Heart Rate and Pulse Transit Time during Paced Respiration," *Physiological Measurement*, vol. 22, pp. 425-432, Aug. 2001.
- [3] K. Nakajima, T. Tamura, and H. Miike, "Monitoring of Heart and Respiratory Rates by Photoplethysmography Using a Digital Filtering Technique," *Medical Engineering & Physics*, vol. 18, pp. 365-372, July 1996.
- [4] K. Meigas, R. Kattai, and J. Lass, "Continuous Blood Pressure Monitoring Using Pulse Wave Delay," in *23rd Annual International Conference of the IEEE EMBS*, Oct. 25-28, 2001, pp. 3171-3174.
- [5] P. J. Chowienczyk, R. P. Kelly, H. MacCallum, S. C. Millasseau, T. L. G. Andersson, R. G. Gosling, J. M. Ritter, and E. E. Änggård, "Photoplethysmographic Assessment of Pulse Wave Reflection: Blunted Response to Endothelium-Dependent Beta2-Adrenergic Vasodilation in Type II Diabetes Mellitus," *Journal of the American College of Cardiology*, vol. 34, pp. 2007-2014, 1999.
- [6] S. C. Millasseau, R. P. Kelly, J. M. Ritter, and P. J. Chowienczyk, "Determination of Age-Related Increases in Large Artery Stiffness by Digital Pulse Contour Analysis," *Clinical Science (London)*, vol. 103, pp. 371-377, Oct. 2002.
- [7] S. R. Alty, N. Angarita-Jaimes, S. C. Millasseau, and P. J. Chowienczyk, "Predicting Arterial Stiffness From the Digital Volume Pulse Waveform," *IEEE Transactions on Biomedical Engineering*, vol. 54, pp. 2268-2275, Dec. 2007.
- [8] K. Li and S. Warren, "High-Fidelity Wireless Reflectance Pulse Oximetry Based on Filter-Free and Surface-Integratable Design," unpublished.
- [9] D. Thompson and S. Warren, "A Small, High-Fidelity Reflectance Pulse Oximeter," in *2007 Annual Conference and Exposition of the ASEE*, Honolulu, HI, June 24-27, 2007.
- [10] J. Yao and S. Warren, "Stimulating Student Learning with a Novel 'In House' Pulse Oximeter Design," in *2005 Annual Conference and Exposition of the ASEE*, Portland, OR, June 12-15, 2005, pp. 12-15.
- [11] M. R. Yuce and C. K. Ho, "Implementation of Body Area Networks Based on MICS/WMTS Medical Bands for Healthcare Systems," in *30th Annual Conference of the IEEE EMBS*, Aug. 20-25, 2008, pp. 3417-3421.
- [12] J. W. Hui and D. E. Culler, "Extending IP to Low-Power, Wireless Personal Area Networks," in *IEEE Internet Computing*, vol. 12, July-Aug. 2008, pp. 37-45.
- [13] S. Rhee, B. H. Yang, and H. Asada, "Artifact-Resistant, Power-Efficient Design of Finger-Ring Plethysmographic Sensors," *IEEE Transactions on Biomedical Engineering*, vol. 48, pp. 795-805, July 2001.
- [14] J. T. Love, S. Warren, G. R. Laguna, and T. J. Miller, "Personal Status Monitor," Sandia National Laboratories SAND97-0418, Feb. 1997.
- [15] J. E. Scharf, S. Athan, and D. Cain, "Pulse Oximetry Through Spectral Analysis," in *12th Southern Biomedical Engineering Conference*, New Orleans, LA, 1993, pp. 227-229.
- [16] Y. Mendelson and B. D. Ochs, "Noninvasive Pulse Oximetry Utilizing Skin Reflectance Photoplethysmography," *IEEE Transactions on Biomedical Engineering*, vol. 35, pp. 798-805, Oct. 1988.
- [17] E. Geun, H. Heo, K. C. Nam, and Y. Huh, "Measurement Site and Applied Pressure Consideration in Wrist Photoplethysmography," in *23rd ITC-CSCC*, 2008, pp. 1129-1132.