

A Milestone-Driven RF Electronics Course for Engineering Technology

Walter E. Thain, Jr.
Southern Polytechnic State University

Abstract

A unique radio-frequency (RF) electronics course was introduced in the Electrical and Computer Engineering Technology (ECET) Department at Southern Polytechnic State University (SPSU). The course was adapted from a two-quarter version currently taught at the California Institute of Technology. Significant modifications were necessary to tailor the course to a single-semester format. Based on the construction and extensive testing of a transceiver with a 7 MHz carrier frequency, the course at SPSU not only tied together concepts students learned in previous courses, but challenged them to see how these principles are applied to practical RF systems. The course also required students to refine their laboratory testing techniques in order to make measurements of sufficient accuracy necessary to quantify the transceiver performance. The course was structured around major milestones at the end of which students must have completed a specified portion of the transceiver construction and testing. After the final milestone, students had a working transceiver.

I. Introduction

With the rapid growth in RF wireless communications systems, it is important that Electrical Engineering Technology programs provide curricula to meet industry demand for graduates with experience in this area. Wireless communications systems consist of transmitter and receiver signal processing subsystems of varying complexity. Wireless system complexity and the diversity in signal modulation techniques used make it impossible to provide a student with sufficient background in one or two courses. Courses in this field usually take either the system-level approach or the circuit-level approach. In the system-level approach, theory behind the transmitter and receiver signal processing is presented with little attention given to the actual circuits that perform these functions. In the circuit-level approach, more detail is presented regarding the design of circuits such as modulators, oscillators, filters, demodulators, and matching networks. Circuit-level courses may even discuss design techniques for particular frequency ranges such as VHF or microwave.

Unfortunately, no matter what approach is taken, wireless communications courses usually do not discuss complete, operational receiver and transmitter systems. The RF Transceivers course discussed here provides this crucial element by involving students with the fabrication and testing of a complete transmitter and receiver unit (transceiver). Thus, students learn transceiver design principles at the system level and the circuit level. The transceiver circuit is an amateur-

radio Morse-code transceiver operating at a 7 MHz carrier frequency (40 meter band). It is essentially a narrowband single-sideband AM communication system that includes classic RF subsystem blocks such as a crystal oscillator, a voltage-controlled oscillator, double-balanced mixers, tuned circuits, a 2-watt Class-C transmitter, matching networks, and a narrowband crystal-resonator filter.

The Southern Polytechnic State University course was adopted from a two-quarter Electrical Engineering laboratory course developed by David Rutledge at the California Institute of Technology. He authored a textbook to accompany the course that presents the theory of the transceiver circuit operation as well as step-by-step laboratory exercises involving the circuit fabrication and testing.¹ The text also includes general-purpose analog Electrical Engineering concepts that are not directly related to the transceiver circuit but are important components of students' background in this field. The greatest challenge to the design of the SPSU version of the course was to reduce the scope from a two-quarter time frame to a single-semester format such that the course retained all the theoretical and laboratory content necessary for students to build, test, and understand the complete transceiver.

In his preface, Rutledge explains the philosophy behind his approach to the textbook as providing a practical, real-world connection between communication theory and circuit implementation, a connection that is often lost in modern Electrical Engineering curricula. Indeed, Electrical Engineering Technology programs seek to include this connection as much as possible in their courses and this is one of the key motivations behind the introduction of this course at SPSU. One important difference in philosophy between the Caltech and SPSU implementations is that at Caltech, the course serves to familiarize students with basic Electrical Engineering concepts through experimentation with a practical system; while at SPSU, it is used more as a capstone course that draws together concepts students learn in earlier courses while also introducing them to practical implementations of RF circuits.

Prior to offering any new course, it is necessary to consider the students' background and capabilities. SPSU's ECET department has a large undergraduate program and a small, but growing graduate program. The latter has a high percentage of international students. Of the graduate students, most have Electrical Engineering degrees and the rest have Electrical Engineering Technology degrees. When the RF Transceivers course was implemented, it was first offered as a graduate special topic course in the Spring 2002 semester to see how students handled the mix of theory and practical implementation. Following that experience, it was offered as a special topic course in Fall 2002 to senior-level ECET students. The undergraduate version was essentially the same as the graduate version with a slight reduction in content. After that, the suitability of the course as a permanent addition to either the graduate or undergraduate program was evaluated.

II. The Transceiver

At the heart of the new course is the NorCal 40A Morse-code transceiver. A block diagram is shown in Fig. 1. It uses a classic beat-frequency oscillator receiver with one intermediate frequency (IF) of 4.9 MHz. The receiver bandwidth is set to about 400 Hz by a coupled-

resonator crystal IF filter. The IF signal is downconverted to a 600 Hz audio tone. An operator deciphers the Morse code information from the long and short tones output by the receiver. An automatic gain control (AGC) circuit keeps the audio tone amplitude relatively constant over a large input signal dynamic range. The transmitter has three amplifier stages, the last being an efficient Class-C type. The transmitter is keyed on and off by the operator. Receiver and transmitter tuning is achieved using a voltage-controlled, variable-frequency oscillator (VFO). A 5th-order passive low-pass passive filter is connected to the antenna and used for the transmitted and received signals. The transceiver schematic and a detailed theory of operation are not included here; however, Table 1 lists some key components and subsystems included in the circuit that make it attractive as the basis for a practical RF course.

The transceiver is available as a kit from Wilderness Radio.² The kit is of high quality and uses a

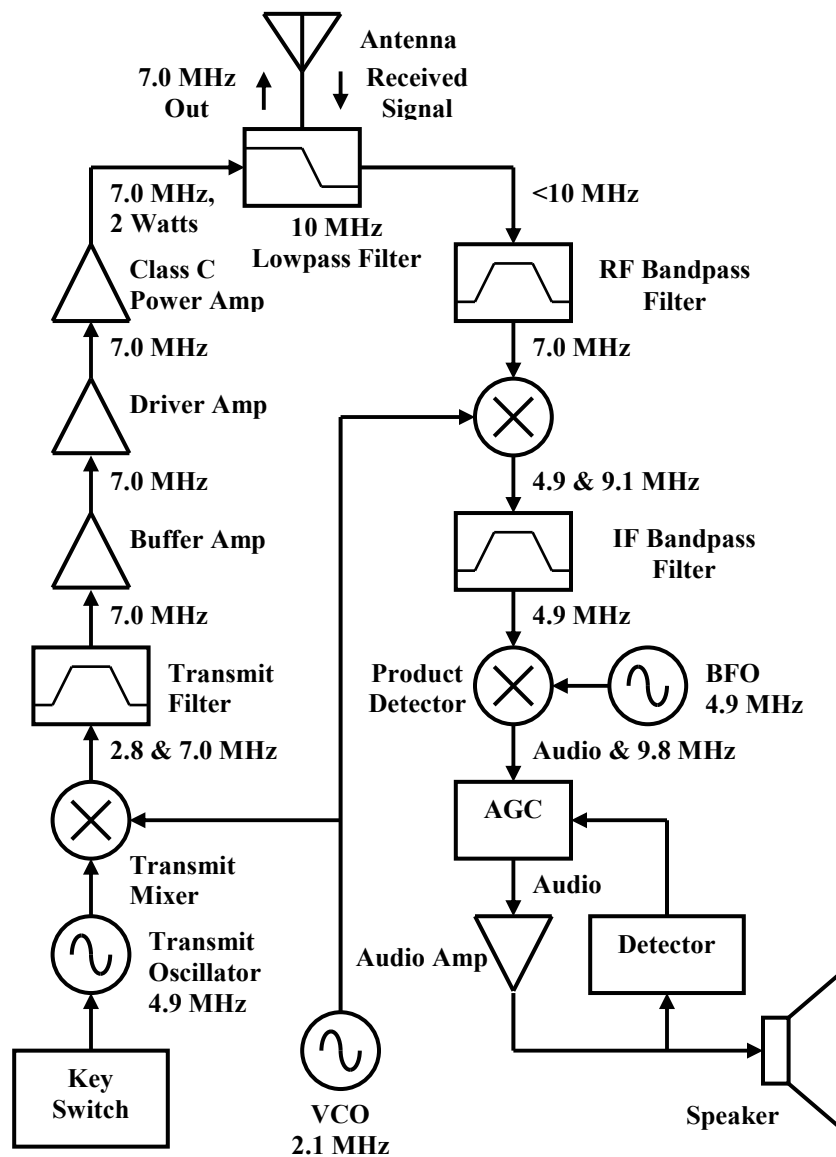

Fig. 1. Block diagram of the NorCal 40A transceiver.

silk-screened, double-sided circuit board with plated through holes. The circuit layout is good; the board has short traces and uses a ground plane where possible. An enclosure is included that gives the finished transceiver a professional-looking appearance. The kit includes an assembly and testing manual, but the steps in the manual do not correlate well to those in the Rutledge text. An assembled transceiver with top and bottom covers removed is shown in Fig. 2.

Table 1. Key components and subsystems in the NorCal 40A transceiver.

Series and parallel tuned circuits
Hand-wound transformers (tuned and untuned) for impedance matching
“L” matching network
Narrowband Cohn coupled-resonator crystal filter with 4.9 MHz center
High-quality integrated circuit mixers
Class-A and Class-C RF amplifiers
BJT and JFET amplifiers
Fixed Clapp crystal oscillator
Varactor-tuned Clapp VFO
Fifth-order passive Butterworth low-pass filter with 10 MHz cutoff
AGC circuit using JFETs as variable resistors
Transistor switches
Audio op amp circuit

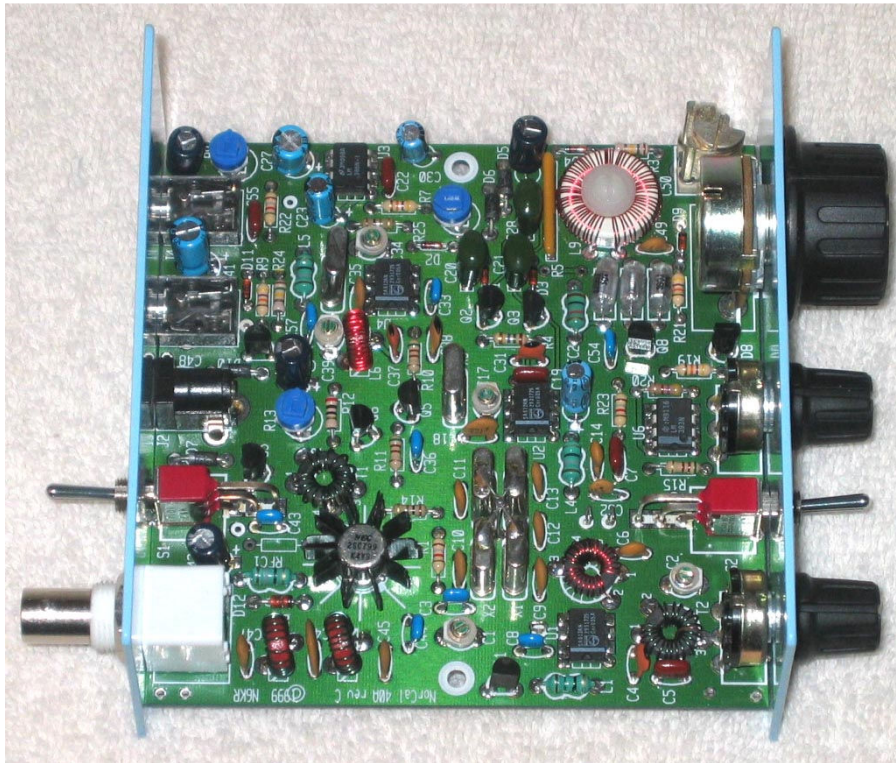

Fig. 2. Photograph of assembled transceiver.

III. The New RF Transceivers Course

The original Caltech course consisted of two 10-week quarters. Each week there were 2.5 hours of lecture and three hours of laboratory time allocated. The laboratory was operated as an open lab without scheduled lab times and was supported by teaching assistants. Students were expected to perform two laboratory problems each week. There were 40 laboratory problems in the text, so students completed all of them in the 20 weeks comprising the two quarters. Not all of these laboratory problems were concerned directly with the transceiver construction and testing. Other Electrical Engineering concepts were covered in the text and some problems were associated with those. This suited the Caltech implementation of this course as a general purpose Electrical Engineering laboratory. Additional information about the Caltech course can be found in Rutledge's *IEEE Microwave Magazine* article.³

The new SPSU course was organized into one 15-week semester with 2.5 hours of lecture each week and a scheduled three-hour laboratory session for 12 of those weeks. The course instructor was present during the scheduled lab session, which was the normal practice in the ECET department. Students were given open access to the lab at other times, but no instructor or teaching assistant was present. The reduced class and lab time allocated for the SPSU course with respect to the Caltech implementation required a reduction in the course content and the number of laboratory problems. Therefore, the SPSU course was restricted to only the textbook content and laboratory problems related to the transceiver construction, simulation, and testing. This meant that only 21 of the 40 laboratory problems were necessary. This suited the intent of the SPSU course as a capstone in the area of wireless communications. Table 2 is a simplified course outline showing the major topics covered.

To give the course more of a capstone flavor, the laboratory portion was organized into four milestones. Each milestone required students to execute a number of laboratory problems from the text and write a concise report summarizing the results of their measurements. They were given the flexibility of completing the laboratory problems at their own pace, as long as the milestone deadlines were met. In the report, they were encouraged to address some of the construction and testing challenges they encountered and were required to include photocopies of

Table 2. Simplified Course Outline.

Week	Topic
1	Introduction, modulation, RF system overview
2	The NorCal 40A overview, circuit components
3	Impedance, RC filters, resonance
4-5	Filters
6	Transformers
7-8	Transistor switches, transistor amplifiers
9-10	Power amplifiers
11	Fixed and voltage-controlled oscillators
12-13	Mixers
14-15	Audio amplifiers, automatic gain control

their lab notes. The photocopies enabled the instructor to correlate elements of the report with their actual results as well as to help the instructor provide relevant comments to the students' regarding their measurement and analysis techniques. At the end of each milestone, the instructor examined the circuit board to ensure that the students had assembled all of the subsystems required for that milestone. Also, emphasis was placed on students maintaining good laboratory notebooks, just as is required in industry.

Students were organized into pairs working with one transceiver. Thus, they benefited from team interaction, but each had to carry a significant part of the workload in the laboratory. Also, this allowed students to share the transceiver parts cost of \$135. It was felt that groups of three or more per transceiver would greatly diminish the laboratory experience, as some would refrain from engaging in lab work. Some ambitious students chose to work alone on a transceiver and were rewarded for taking on the higher workload and cost with extra credit toward their grade. Not all students were suited to working alone on this type of project, so the instructor exercised the right to permit or deny any requests to do so. Regarding grading, 40% of the course grade was allocated to the laboratory portion and the milestone reports and 60% to the classroom portion, the latter evaluated entirely using written exams. The extra credit granted to soloists was 4 points on their final course grade which normally had a maximum of 100.

The SPSU RF Transceivers course was designed to minimize the use of special-purpose laboratory test equipment. A typical bench set up included a dc power supply, a 100 MHz oscilloscope with 10:1 probes, a 15 MHz function generator, a digital multimeter, miscellaneous cables, BNC adapters and 50 ohm BNC loads. The only specialized equipment used consisted of three 110 dB RF variable attenuators employed in the receiver dynamic range measurement. Students had to share these, which did present a problem since some groups required them at the same time. Regarding the function generator, a synthesized model was used that allowed precise output frequency control. This was useful when testing the frequency response of the IF crystal filter. In lieu of a synthesized function generator, a very stable oscillator combined with a frequency counter permits sufficiently accurate measurements. At Caltech, the laboratory included roof-mounted antennas for testing the receiver's ability to detect actual signals. This was not done at SPSU and was not necessary in order to functionally test the receiver; but it would be a welcome addition to the laboratory. Also, students were required to have their own soldering equipment and basic tools in order to assemble the circuit. A couple of soldering stations were provided in the lab, but this was insufficient to handle the demand.

IV. How the Course Fits in SPSU's ECET Curriculum

Prior to the RF Transceivers course, SPSU had two ECET undergraduate courses in the academic catalog focusing on wireless communications systems. The Wireless Communications Systems course introduced students to signal processing schemes used in contemporary wireless receivers and transmitters, concepts behind cellular telephone system implementations, electromagnetic signal propagation, and antenna design. The laboratory component of the course consisted almost entirely of a group project in which students designed, built and tested a UHF antenna. Due to the varied nature of the course content and the time commitment needed for the antenna design and fabrication project, it was not possible to give students a thorough treatment of transceiver design in either the classroom or the laboratory.

The Communications Circuit Applications course was concerned with classic AM and FM transceivers, including single-sideband AM. These topics were discussed from a theoretical and system level with some attention given to practical implementations of individual blocks such as oscillators, phase-locked loops, and matching networks. The laboratory component of the course required students to build and test circuits illustrating key concepts on solderless breadboards, all at frequencies around 100 kHz. This was well below RF, but it ensured that students could achieve success using the solderless breadboard. However, this course did not give students the big picture with respect to a system implementation since they did not build a complete transmitter or receiver.

At the graduate level, there was one Wireless Communication Systems course in the SPSU academic catalog that was more of an advanced version of the undergraduate course. Other special topic courses such as Microwave Systems, Radar Systems, and Antennas have been offered regularly by adjunct professors from industry when they were available, but these have not been added permanently to the catalog. The ECET department is seeking to add permanent graduate courses this area.

V. Instructor and Student Experiences

The RF Transceivers course was challenging to run the first time, since the instructor was creating course notes and constructing the transceiver himself, sometimes completing steps only a week or so before the students. The first offering was to graduate students, who did not have too much difficulty in the classroom but a number struggled in the laboratory. It was clear that for some this was their first construction project, and quite a few were not too comfortable setting up and executing the measurements. Students with an Electrical Engineering Technology background or industry experience had a distinct advantage in the laboratory. It should be noted that there were some graduate students for whom communications systems and RF circuits were not their primary areas of interest. Due to the small size of SPSU's ECET graduate program, it is difficult to offer a large enough number of courses each semester to allow them to concentrate in one area of interest.

The graduate class size was 21 with a single lab section. This lab section was too large for a single instructor without the aid of student assistants; but, unfortunately none were available. Several teams required a considerable amount of instructor attention, which was impossible for one instructor to provide in a timely manner. When the course was taught the second time to undergraduate students, the class size was only nine. This was a much more manageable size and the experience gained from the graduate course allowed the instructor to warn the undergraduate students of difficulties they would encounter with particular lab problems.

The laboratory portion of the course was time consuming. Even though students were warned at the beginning of the course that they would have to invest a lot of time in the lab, they did not realize just how much until about the third or fourth week. Even the best students needed to spend more time per week on average than the assigned three-hour lab time. More troubleshooting time was required for those with poor construction skills. These students also required more personal attention from the instructor.

A survey was distributed to the students to get their feedback on the course. For the graduate class, almost all students found the course to be valuable. The most appreciated aspects of the course were the experience they gained constructing a functionally complete RF transceiver, learning to make good laboratory measurements, and learning troubleshooting skills. A majority found the lecture content valuable and challenging, but not as much as the laboratory work. By far the most popular complaint from the graduate students was the large student/instructor ratio in the laboratory. Almost equal in frequency was the complaint was that the laboratory portion of the course took too much time. Some also commented that their understanding of lecture material would benefit from more worked-out examples.

For the most part, comments from the undergraduate class were the same as from the graduate class. However, some students felt that some of the lecture content was hard to grasp. As expected, there were no complaints about the student/instructor ratio since the class size was nine. The nature of the comments did show that students with an Engineering Technology background were more comfortable in the lab, even though they may not have performed the particular measurements required in this course.

VI. Conclusions

RF Transceivers was an excellent course and was well suited for Engineering Technology students. Students in both the graduate and undergraduate versions appreciated the comprehensive way in which a wireless transceiver was examined and the hands-on experience they gained working with a well-designed circuit. Implementing the SPSU version as a milestone-based course was successful, as it permitted students some flexibility as to when they accomplished the laboratory problems and it required them to manage their time wisely. This is valuable for students without industry experience. The flexibility also benefited the instructor, since lectures did not have to be as tightly coupled to the laboratory schedule as was the case with the Caltech course. Also, adapting the course to serve as a capstone in the area of wireless systems appeared to work well. However, for the most part the course did not have a significant design component, although there were some design and simulation laboratory problems. Also, using the course as Caltech did as an introductory undergraduate Electrical Engineering laboratory would not be well suited to an Electrical Engineering Technology program like SPSU's, since every course but two in our curriculum already had an accompanying laboratory component and the subject matter would be too challenging for the average sophomore and junior.

The textbook is very good and the instructions for the laboratory problems are thorough. Occasionally students have trouble understanding the procedures, but a little clarification by the instructor is all that is needed. It would be nice if there were more worked out examples or practice problems in the text, but the Caltech implementation as a laboratory course does not require it. An instructor can create some additional practice problems for students. Nevertheless, the textbook is written in such a way that it is easy for an instructor to design a course around it. Included in the text are lists of equipment needed for each laboratory problem, data sheets for all ICs and transistors in the transceiver, and a tutorial on using the Puff circuit simulator that is included with the text and used in several laboratory problems.

Advice to those considering adopting this course is as follows. Build one of the transceivers yourself, performing each step and calculation you expect your students to make and do so well in advance of the students the first time through. Also, laboratory teaching assistants should build the transceiver prior to working with students in the lab. The single-semester version of the course implemented at SPSU is very challenging and time consuming. The course will not work well in a single quarter or a semester format consisting of less than 14 or 15 weeks. Even though courses in a 5- or 10-week short semester format have the same class and lab hours as a 15-week semester, students will have great difficulty managing the laboratory time commitment. Reducing the number of laboratory problems below the 21 implemented in SPSU's course is possible, but will detract from the value of the course. Check on availability of the transceiver kits prior to listing the course for students to enroll to ensure that you can order them and receive them in time. Last but not least, it is recommended that the laboratory student/instructor ratio be kept small.

There are some important concerns with a course like this. One is the cost of the kit, which is high even if two students share it. Subsidizing the cost or providing the kits for students would help. Also, there is no second source for the kit. If Wilderness Radio stops selling it, either your department will have to support it or you must stop offering the course. Another concern is that the text does not have a great amount of theoretical depth in any particular area since most of the concepts presented are oriented toward the laboratory problems. Indeed, it would be difficult to add more depth to the course and complete it in one semester. Also, the NorCal40A is an amateur radio transceiver and Federal Communications Commission (FCC) regulations require that anyone using it to transmit have an appropriate amateur license. Therefore, students are not legally permitted to use the transceiver to transmit, but they can receive with no restrictions. Lastly, there are occasions when specialized test equipment is required for some laboratory problems, such as the stepped RF attenuators used to test receiver dynamic range. It is up to the instructor to decide how to teach the course, which laboratory problems to include, and to choose the test equipment to include in the laboratory. The equipment lists the text includes for each laboratory problem help considerably.

Finally, recall that the both the graduate and undergraduate version of the RF Transceivers course were offered experimentally as special topics courses and have not been added to the SPSU catalog. It is felt that the undergraduate version should be added, but the graduate version may not be challenging enough with respect to the technical content. Concerning its suitability for Electrical Engineering programs, either the Caltech version or the SPSU version of the course would probably be a good fit in an undergraduate program that emphasizes applied courses.

References

1. Rutledge, David, *The Electronics of Radio*, New York, Cambridge University Press, 1999.
2. URL: <http://www.fix.net/~jparker/wilderness/nc40a.htm>, Wilderness Radio NorCal40a web page.
3. Rutledge, David, "The Electronics of Radio: Teaching College Electronics With an Amateur Transceiver, *IEEE Microwave Magazine*, June 2000, pp. 94-99.

Biographical Information

WALTER E. THAIN, JR.

Dr. Walter E. Thain, Jr. is an Associate Professor of Electrical and Computer Engineering Technology at Southern Polytechnic State University. He teaches in the areas of networking, communications systems, and analog and digital electronics. He spent 12 years in industry designing mixed analog-digital systems, including short-pulse radars and antennas, low-noise analog circuits, RF circuits, frequency synthesizers, and switching power supplies.