



A Multidisciplinary Energy Project: Re-building a Non-working Electric Car with Students

Dr. Faruk Yildiz, Sam Houston State University

Faruk Yildiz is currently an Associate Professor of Engineering Technology at Sam Houston State University. His primary teaching areas are in Electronics, Computer Aided Design (CAD), and Alternative Energy Systems. Research interests include: low power energy harvesting systems, renewable energy technologies and education.

Dr. Keith L. Coogler, Sam Houston State University

Dr. Keith L. Coogler is an instructor of engineering technology at Sam Houston State University. He received a BS in Design & Development and holds a MA in Industrial Education and Ed.D. in Higher Education from Texas A&M University – Commerce. His primary teaching area is Construction Management. Research interests include: automation, electronics, alternative energy, and "green" construction.

Dr. Reg Pecen, Sam Houston State University

Dr. Reg Pecen is currently a Quanta Endowed Professor of the Department of Engineering Technology at Sam Houston State University in Huntsville, Texas. Dr. Pecen was formerly a professor and program chairs of Electrical Engineering Technology and Graduate (MS and Doctoral) Programs in the Department of Technology at the University of Northern Iowa (UNI). Dr. Pecen served as 2nd President and Professor at North American University in Houston, TX from July 2012 through December 2016. He also served as a Chair of Energy Conservation and Conversion Division at American Society of Engineering Education (ASEE). Dr. Pecen holds a B.S in EE and an M.S. in Controls and Computer Engineering from the Istanbul Technical University, an M.S. in EE from the University of Colorado at Boulder, and a Ph.D. in Electrical Engineering from the University of Wyoming (UW, 1997). He served as a graduate assistant and faculty at UW, and South Dakota State University. He served on UNI Energy and Environment Council, College Diversity Committee, University Diversity Advisory Board, and Graduate College Diversity Task Force Committees. His research interests, grants, and more than 50 publications are in the areas of AC/DC Power System Interactions, distributed energy systems, power quality, and grid-connected renewable energy applications including solar and wind power systems. He is a senior member of IEEE, member of ASEE, Tau Beta Pi National Engineering Honor Society, and ATMAE. Dr. Pecen was recognized as an Honored Teacher/Researcher in "Who's Who among America's Teachers" in 2004-2009. Dr. Pecen is a recipient of 2010 Diversity Matters Award at the University of Northern Iowa for his efforts on promoting diversity and international education at UNI. He is also a recipient of 2011 UNI C.A.R.E Sustainability Award for the recognition of applied research and development of renewable energy applications at UNI and Iowa in general. Dr. Pecen established solar electric boat R & D center at UNI where dozens of students were given opportunities to design solar powered boats. UNI solar electric boat team with Dr. Pecen's supervision won two times a third place overall in World Championship on solar electric boating, an international competition promoting clean transportation technologies in US waters. He was recognized as an Advisor of the Year Award nominee among 8 other UNI faculty members in 2010-2011 academic year Leadership Award Ceremony. Dr. Pecen received a Milestone Award for outstanding mentoring of graduate students at UNI, and recognition from UNI Graduate College for acknowledging the milestone that has been achieved in successfully chairing ten or more graduate student culminating projects, theses, or dissertations, in 2011 and 2005.

He was also nominated for 2004 UNI Book and Supply Outstanding Teaching Award, March 2004, and nominated for 2006, and 2007 Russ Nielson Service Awards, UNI. Dr. Pecen is an Engineering Technology Editor of American Journal of Undergraduate Research (AJUR). He has been serving as a reviewer on the IEEE Transactions on Electronics Packaging Manufacturing since 2001. Dr. Pecen has served on ASEE Engineering Technology Division (ETD) in Annual ASEE Conferences as a reviewer, session moderator, and co-moderator since 2002. He served as a Chair-Elect on ASEE ECC Division in 2011. He also served as a program chair on ASEE ECCD in 2010. He is also serving on advisory



boards of International Sustainable World Project Olympiad (isweep.org) and International Hydrogen Energy Congress. Dr. Pecen received a certificate of appreciation from IEEE Power Electronics Society in recognition of valuable contributions to the Solar Splash as 2011 and 2012 Event Coordinator. Dr. Pecen was formerly a board member of Iowa Alliance for Wind Innovation and Novel Development (www.iawind.org/board.php) and also represented UNI at Iowa Wind Energy Association (IWEA). Dr. Pecen taught Building Operator Certificate (BOC) classes for the Midwest Energy Efficiency Alliance (MEEA) since 2007 at Iowa, Kansas, Michigan, Illinois, Minnesota, and Missouri as well as the SPEER in Texas and Oklahoma to promote energy efficiency in industrial and commercial environments.

Dr. Pecen was recognized by State of Iowa Senate on June 22, 2012 for his excellent service and contribution to state of Iowa for development of clean and renewable energy and promoting diversity and international education since 1998.

Dr. Ulan Dakeev, Sam Houston State University

Dr. Ulan Dakeev is an Assistant Professor in the Engineering Technology Department at Sam Houston State University. His areas of research include Virtual & Augmented Reality, renewable energy (wind energy), quality in higher education, motivation, and engagement of students.

A Multidisciplinary Energy Project: Re-building a Non-working Electric Car with Students

During the last decades of the 20th century, many electric vehicles (EV), such as pure electric vehicles, fuel cell vehicles, and hybrid vehicles, were developed to solve the air pollution problems in cities caused by traditional internal combustion engine vehicles. Environmental concerns, depletion of fossil fuel resources, and the increase in gas prices boost the demand for EV and plug-in Hybrid Vehicles (HV) because of their higher efficiency and low or no gas emission. Also, strict emission requirements triggered leading to the research on efficient, environment friendly and less fossil fuel dependent solutions in the transportation field. Since EVs and HVs are commercially available today, they are of special interest for many people – from car owners to technicians, scientist to technology followers. This interest bring a necessity to academia to educate students for future workforce about EVs. A team of students from a various programs under Engineering Technology (ET) department worked on a non-working electric car over a year as part of their class (*special topics: experimental engineering projects*) and independent study course projects. An old car (1984 model) was converted to a fully electric car around 10 years ago in a company owned by one of the engineering technology program alumni. A couple years ago, the car was donated and transported to ET department for potential student research and teaching activities. However, the car was in a non-working condition with a minimal written instructions. Students and faculty members spent extensive time and efforts to study mechanical and electrical systems of this converted car in order to turn in a research opportunity and use potential energy related coursework. After a year of work including inspection and registration process the electric car became a working automobile. The vehicle became a very good demonstration and recruiting tools for ET programs as well as clean energy promoting tool.

Introduction

EVs are old concept, started in 1902 together with the internal combustion engine, that when Woods electrically powered phaeton traveled for 18 miles with an average speed of 14mph. However only recently in the last decades of the 20th century, a lot of EVs, such as pure electric vehicles, fuel cell vehicles and hybrid vehicles, have been developed to solve the air pollution problems in cities caused by the traditional internal combustion engine vehicles. The pure EVs have relatively few components, the largest part being the battery. The batteries are connected to an inverter, which converts the direct current into alternating current for the motor driving the wheels [1-3].

Cars consume much of the oil that is used all over the world. The major source of air pollution comes from vehicular emissions. Therefore, cars and truck fleets have been considered and carry major responsibility for the environmental issues, faced at least at urban level. The constantly increased total amount of vehicles worldwide corresponds to increased energy consumption and enormous emissions, both during their production and use phases. To overcome this problem, car manufacturers have designed and developed several types of environmentally friendly vehicles, mainly based on electric motors. The types of these vehicles are battery powered electric vehicles, fuel cell powered electric vehicles, hybrid vehicles and, the solar powered electric vehicles [4].

The general and typical principles for building such vehicles are as follows: one or more electric motors are used as primary or secondary mechanisms to guarantee vehicle's motion, while the differences between the different types of EVs encountered on the energy storage systems and the way that it is charged. In this context, there are two main classes of EVs: the vehicles that must be connected to the grid in order to charge their storage system and those that are autonomous, assuring enough energy by off-grid sources. Actually, the "grid-charged" vehicles must be considered as "emissions-elsewhere-vehicles" rather than "zero-emission vehicles" [5].

As the effects of climate change have been widely reported, consumers have begun to look for green alternatives to implement into their daily lives. There has been an increasing demand for electric and hybrid vehicles to provide a solution to conventional forms of travel. Currently, conventional cars are large consumers of fossil fuels. It is widely known that the burning of fossil fuels contributes to CO₂ emissions. Thus, finding a clean alternative, although a daunting task, is well within reach with the ever-improving technology of the modern era [6].

Educating students in the production and technology of electric and hybrid vehicles is essential to making the technology more accessible. Ohio State University designed and implemented a semester long course for freshmen students to better understand green technology. The goal of the course was to "create awareness...of the need for research and development of advanced energy technologies and system..." [7] Among learning the necessary programming required, students were required to build an advanced energy vehicle (AEV). For this task, students worked in teams. Each team was responsible for doing research, experimenting with an optimal vehicle design, and producing the final, working design. At the end of the course, students were required to produce a report covering the steps they took from the start of the project until the end, including time constraints and other issues they may have run into. They were then given the opportunity to present their research and final design to their peers. Providing students with the background to understand the technology is necessary to providing them with the tools needed to design, build, and improve on current green technologies. A course like this is especially helpful for fostering student's assuredness in their ability to be creative with new technologies. The course encourages the students to experiment and test the limits of the technology they are working with, which could lead to them noting where improvements can be made [8-9].

Background

The car was initially converted to electric at a company owned by one of the program alumni in 2008. After a 100-year centennial visit made by alumnus, He decided to donate the car to department for the young minds to learn and use this technology. The car received by the department shortly after, but was not functioning. The car came with a basic manual for converting electric cars. This manual provided schematics and details that were found to be useful during the refurbishment of the car. The car is powered by twelve series-connected deep-cycle lead-acid batteries. Observations indicated the batteries were swollen and distorted. Phone calls were made to the prior owner and they reported that the car had been stored in an unheated storage area at their facility. They acknowledged that the temperature had been below zero degrees (Fahrenheit) and the batteries most likely froze. The car is shown in Figure 1.



Figure 1. Electric Car

Project Steps

Storage

The car was diagnosed by measuring the voltage in the batteries. A high-end battery tester was used to test the battery banks. It was revealed that the batteries had no charge or voltage and were beyond repair. One of the local battery vendor agreed to exchange dead batteries with the refurbished deep cycle marine batteries at no cost. New propulsion batteries installed and tested very carefully by the students and faculty.

Replacement batteries were sought and new deep-cycle batteries were donated for our project by a battery company. All batteries received, and students began charging them to full capacity. Although the car now had power available, it did not run. Students checked all fuses and were found to be good. Problems existed in the electrical wiring. The main disconnect was opened to keep the batteries from draining. The following week students checked the batteries and found them drained. Once again all batteries were charged but this time they were not hooked up. Students determined the electrical wiring problems and corrected it. The car was now drivable. The draining of the batteries was caused by instrumentation that was wired in to the batteries prior to the disconnect switch.

The original car owner had installed a 120 volt fork lift battery charger in the trunk of the vehicle to charge the batteries. Students hooked it up and applied line power to the charger to charge the batteries. After about an hour of charging, the students began checking batteries to verify the voltage was increasing. What they observed was that the batteries were becoming very imbalanced. Some batteries were taking a charge and others were not. The charger was disconnected and the batteries were charged individually. Project team noticed the charger that was in the car was the cause of the damage in the old batteries, the charger was out for further testing and potential repair.

Charging Unit

Individual batteries do not charge at the same rate when connected in series. Students began trouble-shooting by researching similar cases found on the internet. Several articles indicated that this phenomenon is due to the large number of series-connected batteries being charged [10-11]. Up to about four series-connected batteries will charge adequately provided they are the same type and condition. There are twelve series-connected batteries in this car.

Student further research found examples of charging multiple batteries but required very expensive charging stations. They decided to find a way to charge the batteries while in the car. After reading about the various types of charging cycles for lead-acid batteries, they eliminated some for their purpose. After brainstorming and discussions about the methods, commercially available chargers, and economics of each method; they decided to use multiple trickle/float chargers. Trickle charging would allow them to charge a slightly discharged battery back to full capacity. Float charging maintains a fully charged battery at full capacity by compensating for storage depletion the battery. They researched and found a trickle/float charger used for motorcycles, riding mowers, and recreational vehicles. A single charger was purchased to verify that it would function as advertised and fulfill the need of maintaining the batteries in the car.

After searching a variety of charging options it was decided to use a trickle- cell charger to keep the batteries charged. A charging station with six trickle cell chargers were built in the front and six in the back that were each connected to an individual battery. All the chargers connected at a power strip where they received energy. This charging setup allowed each individual battery to have its own dedicated smart charger. This insures the batteries will not be overcharged and damaged. Batter tester and trickle charger are shown in Figure 2.

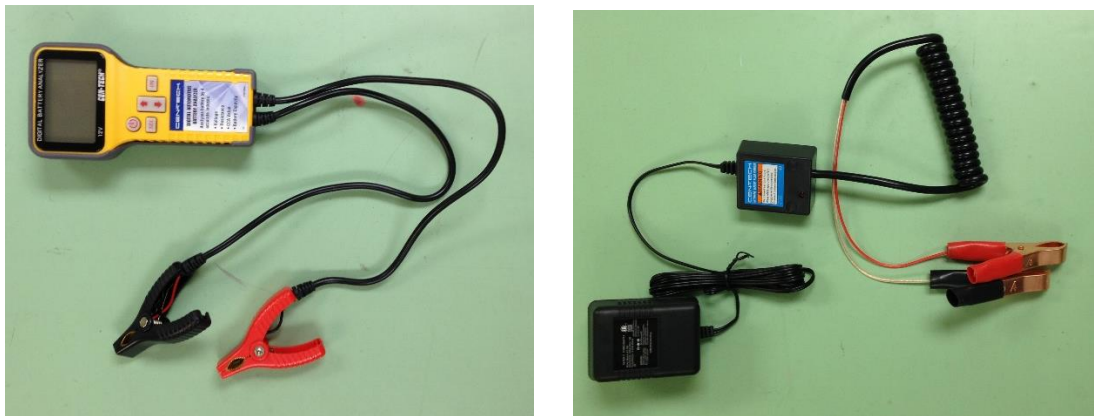

Figure 2. Battery tester and trickle charger

Re- Design and Building the Charging System

Having found and proven that their charger would work, five additional units were purchased and mounted on a board and the chargers plugged to a six outlet power strip. This assembly would be kept in the trunk of the car. Each charger was connected to one of the series-connected batteries when the car was not in use. Battery charger literature indicated that there must be no load on the battery. Each charger “sees” (Sic. monitors) only the voltage across one battery [12].

The charging station was connected to six slightly discharged batteries and left to charge overnight. The batteries were checked the next day and found to be fully charged – the system worked. An operational procedure was designed and printed to prevent charging while a load is on the series-connected battery set. Additionally, the procedure calls for removing the charger leads prior to operation of the car.

Each charging station has 6 trickle charges totaling up to 12 charges for all 12 batteries. Both charging stations were placed in the trunk of the car where there were more space to place the stations. The charges are wired to batteries and tested to make sure batteries receive charge. The schematic of the trickle charging station is shown in Figure 3.

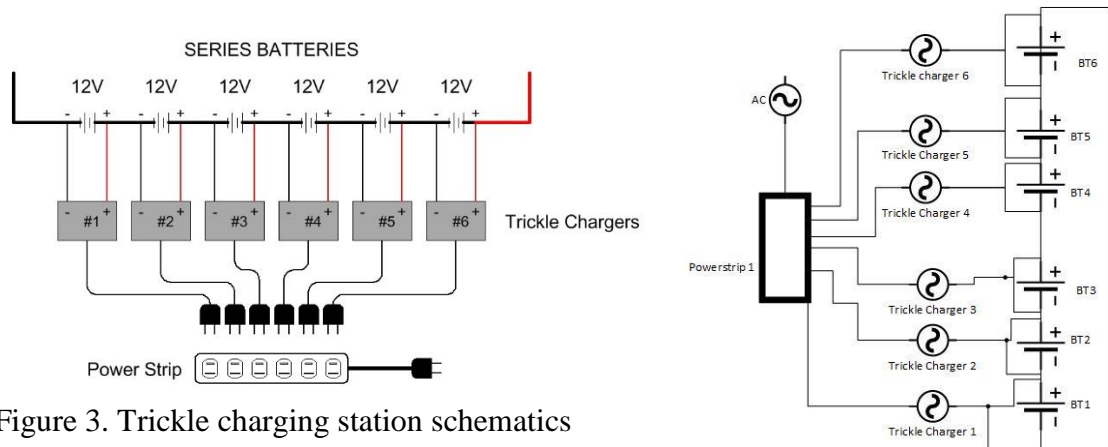

Figure 3. Trickle charging station schematics

Inspection

Students evaluated the status of the car for state inspection to be street legal. It was found that the brake and tail lights needed to be replaced and the headlights were not working. The bulbs on the rear lights were replaced and altered the wiring to the front headlights to bring them up to par. Then the car is taken to school vehicle inspection station on campus to get inspected and insured.

Cost Evaluation

There was a cost associated with some parts and devices purchased. Table 1 shows the cost of the parts and devices for this project.

Table 1. Cost

Part/Device	Quantity	Cost
Battery	12	\$0
Lights	9	\$57
Tire	1	\$0
Trickle Chargers	12	\$144
Battery Analyzer	1	\$86

Student Involvement

This project has been proposed to provide an interesting research area for studies which, result in real outcome. The students received an electric car in non-working condition, but after their work, the car is now operable and is street legal. The team diagnosed that the batteries had failed because of the poorly designed charging system. The failed batteries were replaced, and the team redesigned the charging system to be a parallel setup. From this experiment, the students learned how deep cycle marine batteries react to discharge and recharge while in a series connection. They also learned how to properly charge these batteries while connected in series without damaging them. Working with undergraduate students can be a challenge to the course instructor because undergraduate students have less knowledge and have had less preparation for potential interdisciplinary research projects. Most of the students in this course were taking a full load of classes and working in part/full time jobs. However, the overall comments and observations of faculty and students indicated that there were true team dynamics and students were enthusiastic about their project. They also agreed that students gave them an impression that having to work under time constraints, communicating and working with industry would greatly benefit their engineering careers.

All the projects including fixing electric car started in an experimental engineering project course which was taught first time in the department in lieu of a capstone project course. There were a couple of team projects in this course including electric car project. Due to time constraints in the class the project was incomplete. However, same and more students were interested to work on the same project either as volunteer basis or enrolling in an independent/directed study courses. Faculty advisors worked with students on weekly basis and created a time/work log for each student to fill out the work progress and details of the duties. Every week the project progress is reviewed by the project advisors and students together. Each student was given time to share the part of the project he/she was responsible and explain what student learned. Other students in the group were given a chance to ask questions to other team members.

Conclusion

Students always encouraged to take part in undergraduate research activities. This project has started in an experimental engineering projects course where students were divided into several groups for their projects. One of the groups consisting of four students wanted to work on the electric car but did not have a chance to complete the project during the course period. However, same students with other students either signed up directed/independent study courses and as volunteers to complete the project. The results of this project showed the importance of alternative energy vehicles as well as the integration of these technologies into everyday life. This project helped the students to become leaders in the research and development of alternative energy vehicles. From studying these forms of energy, the students left with more knowledge of energy conversion and hybrid electric vehicles. The students took an inoperable electric car and replaced the components necessary to make it functional. Although this project was plagued with issues from the start, students were able to assess the problems and through collective brainstorming, devised a remedy to the battery charging issue. The students were able to design and employ a battery charging station as a means to implement their remedy. Using the basics of electronics learned in school, they furthered their knowledge and understanding related to multi-cell battery

recharging – something not typically covered in their course work. Although the charging station may not be the most efficient, the students were under a financial constraint. They did come away aware that there are devices that can optimize charging and maintenance of batteries that should be evaluated if they have multi-cell battery systems in the future.

References

- [1] Frank Leslie's Popular Monthly (January, 1904), "Woods Motor Vehicle Company". The Crittenden Automotive Library. Retrieved February 3, 2020.
<http://www.carsandracingstuff.com/library/w/woodsmotorvehiclecompany.php>
- [2] Hybrid from a time of transition – the 1916 Woods Dual Power Model 44. Retrieved February 3, 2020.
<https://www.hemmings.com/blog/2013/03/21/hybrid-from-a-time-of-transition-the-1916-woods-dual-power-model-44/>
- [3] Electric Vehicles, Office of Energy Efficiency & Renewable Energy, US Department of Energy. <https://www.energy.gov/eere/electricvehicles/electric-vehicles>
- [4] R.B. Gmbh, "Automotive Handbook (8th ed.)", In: Bentley Publishers, Stuttgart, Germany, 2011.
- [5] C.C. Chen, "The state of the art of electric, hybrid, and fuel cell vehicles", Proc. IEEE, vol. 95, pp. 704-718, 2007.
- [6] Larminie, James, and Lowry, John (2012). *Electric Vehicle Technology Explained*. (2nd ed.). West Sussex, United Kingdom: John Wiley and Sons, Ltd.
- [7] Whitfield, C. A., Schlosser, P. A., Merrill, J. A., Riter, E., & Agarwal, K. (2011). Advanced Energy Vehicle Design-Build Project for First-Year Engineering Students.
<https://www.asee.org/public/conferences/1/papers/761/download>
- [8] Dave, J., & Dong, J. (2009, June), *Conversion Of An Existing Car To A Rechargeable Electric Vehicle* Paper presented at 2009 Annual Conference & Exposition, Austin, Texas.
<https://peer.asee.org/4622>
- [9] Schlosser, P.A., Gustafson, R.J., "Advanced Energy Hybrid Vehicle Design-and-Build Project for First-Year Engineering Students", Proposal, The Institute of Energy and the Environment, 2009.
- [10] Aspiyan Gazder, Linear Technology Corp. eeNews, *Balancing Lead-Acid Batteries*. January 13, 2016, <https://www.eenewsautomotive.com/content/balancing-lead-acid-batteries>
- [11] Analog Devices. LTC3305 Lead Acid Battery Balancer.
<https://www.analog.com/en/products/ltc3305.html>

[12] SiC Semiconductors
<https://www.controleng.com/articles/sic-semiconductors/>