



Assessment of an Industry-Sponsored Mechatronics Capstone Design Project

Dr. Matthew Quincy Marshall, Kennesaw State University

Matthew Marshall received a Doctorate in mechanical engineering from Georgia Tech in 2013 and then began teaching for KSU's Mechatronics Engineering department. He has taught Mechatronics Engineering Fundamentals, a special-topics course for the Arduino computer, a special-topics course in 3-D modeling (CAD) and simulation, Advanced Controls, plus Instruments and Controls. His research deals with camera-based guidance for robots and robot kinematics. Dr. Marshall's work experience includes design of automation systems, structural/architectural products, and mechanical devices.

Dr. Chan Ham, Kennesaw State University

He is an Associate Professor in Mechatronics Engineering at the Kennesaw State University since 2010. He has over eighteen year experience in Mechatronics education and research.

Assessment of an Industry-Sponsored Mechatronics Capstone Design Project

Matthew Marshall
Mechatronics Engineering Dept.
Kennesaw State University
Marietta, Georgia 30060
mqm@kennesaw.edu

Chan Ham
chan.ham@kennesaw.edu

Abstract

Capstone students in an undergraduate mechatronics engineering program utilize industry-applicable techniques: a design-build-test process frequently used in commercial environments. For a particular industry-sponsored project, this paper presents sample rubrics and student feedback to evaluate the model in this course. The present work is a case study for a team modifying a magnetic-wheeled inspection robot. Mechatronics engineering is, by nature, a multidisciplinary endeavor; the student group employed electronic sensors, actuators, computer programming and I/O, controls, and mechanical design. The project, sponsored by a local testing company and carried out by a four-student team, is shown to have been mutually beneficial. The sponsor identified key areas for improvement of the original embodiment of the robot. The team then carried these additions and modifications from design through testing. Learning outcomes are assessed based on the class evaluation scheme and the unique benefits of an industry-sponsored project are considered. Student and sponsor response indicates that the skills and practices learned in this course are directly applicable to the engineering profession.

Introduction

MTRE 4800 is one-semester, four-credit senior capstone design class of the Mechatronics Engineering Department at the Kennesaw State University (KSU). The main class objective is to cover the design of a multidisciplinary mechatronics system, requiring mechanical, electrical, and computer engineering. A multi-disciplinary approach has been popular in capstone courses¹. Students in the course learn fundamentals of engineering design. Projects are assigned to students based on availability of equipment and facility, as well as the technical interest of students. Class



Figure 1: C1 Spider crawler

projects require planning, proposal presentation, scheduling, engineering, implementation, and written and oral presentations of project results. The sequential nature of these assignments in the design-build-test model is common for capstone-project courses at elite universities². Students' abilities to "design and build" come by utilizing concepts learned from courses throughout the program.

At the beginning of the semester, various design-project candidates are presented. There are two types of projects; one is sponsored by industry or faculty and the other one is conceived by students. Based upon students' expression of interest, they will be assigned to a project and a team. Assigning projects based on interest levels increases student engagement³. Inter-student communication and student engagement in learning have been found to be the most important factors in college education^{4,5}. Teams usually comprise three to four students, which is reportedly the optimal size⁶.

This paper describes the work of a four-student team that selected a project sponsored by Applied Technical Services (ATS), a local consulting firm in Marietta, Georgia who uses C1 Spider crawlers from ScanTech Instruments Inc. (shown in Figure 1 and henceforth referred to as the Spider) to measure the thickness of pipes at customer facilities. At locations such as paper mills, pipes degrade and corrode naturally over time during regular use, so it is critical that the condition of these pipes be monitored, and when necessary, replaced. Using this thickness data, ATS can search for signs of corrosion and make recommendations about what maintenance and replacement should be done. The Spider utilizes magnetic wheels to cling to the sides of the pipes, but there are situations in which the crawler will lose adhesion and fall to the ground from a height of up to 100 feet. Since the Spiders represent a significant investment for ATS, they contacted the Department of Mechatronics Engineering for assistance in addressing this issue. This project provided students with the opportunity to be directly involved in the design of improvements to a system currently used in industry. The present work uses this project to assess the effectiveness of MTRE 4800 in students' education and preparing them for the professional work environment³.

In MTRE 4800, the design must be carried through the conceptual and detailed design phases, followed by building and testing a prototype according to the design specifications selected. At

the end of semester, a single overall report will be required from each team that details the team's work in order to integrate the various components into the complete design⁷. The entire team will be responsible for ensuring its completeness and organization. The submission of the design projects is mandatory. Completion of the prototype is a requirement of this course, which is defined as the building, testing, and evaluation of the prototype. Additionally, each student will be required to maintain an engineering logbook of the efforts on the project, keeping track of the time spent, the tasks being worked on, etc. The logbook is submitted to the instructor at the time of the final examination. Peer evaluations also are used for assigning grades, which increases cooperative learning⁸.

The major learning outcomes of the course and assessment tools are provided in Table 1 and the evaluation scheme can be found in Table 2⁶. Of particular interest are the two design reviews, the Preliminary (PDR) and Critical (CDR), as they represent the heart of the design experience.

The written report of the PDR reviews the initial design relative to the design requirements. Emphasis is given to project management and systems engineering, providing the instructor a mid-course opportunity for judging completeness and consistency with standards; raising and resolving any project-related issues; and identify and mitigating project, technical, and even group dynamic issues. The CDR is also a written report. It is provided at the 90% completeness level, providing assessment of the design prior to prototype fabrication⁷.

Thirty percent of a student's grade is based on individual performance and 70% on group evaluation. The notebook, exams, and peer evaluations are all scored individually. In addition to that, students must indicate their individual contributions to the CDR, which completes the 30% of the course grade based on individual effort.

The rubrics for all assessment tools are provided in Table 3. The Spider team's performance on major assignments is presented as Appendix A to demonstrate use of these rubrics.

For industry-sponsored projects, feedback from the sponsor on the team's performance is obtained. This and the Spider team's self assessments are presented in a later section.

Overview of Spider project

The Spider project has many elements of a real-world engineering assignment: observation of shortcomings in an existing design prompted a desire for improvements, the sponsor's managerial staff provided oversight, and limitations required budgeting of temporal and pecuniary resources. The sponsor described its support for the project as, "physical access to the unit, background information, limited specifications, and consulting opportunities with the unit operator." The students' experiential learning from this project was honed by constraints on size, weight, and component availability. Group assignments containing elements of cooperative learning yields greater learning outcomes than comparable effort spent on individual tasks⁹. The involvement of engineering staff from the sponsoring business provides increased interdependence and thus a more productive cooperative-learning experience.

To illustrate the industry impact on system requirements, details of the Spider are presented. Four magnetic wheels hold the Spider to ferromagnetic surfaces. The Spider drags behind it a

Table 1: Learning outcomes and assessment tools

Course learning outcome	Assessment tool
Develop minimum success criteria for a mechatronic system to be implemented	Preliminary report
Manage team tasks by assigning leads for mechanical, electrical, and coding system components	Peer evaluation
Explore case studies in professional ethics	Homework
Present work to an informed audience	Project presentation and demonstration
Demonstrate intellectual curiosity through formulation of project ideas and solutions	Project Proposal
Demonstrate the ability to independently learn a technical subject through self-study	Prototype development

Table 2: Course grading scale

Grade item	Percent of total score
System Concept Review (SCR) and System Requirements Review (SRR) (presentation only)	5%
Preliminary Design Review (PDR) presentation and written report	10%
Critical Design Review (CDR) presentation and written report	25%
Demonstration of prototype (no credit if the prototype doesn't work)	30%
Notebook	10%
Other presentations/exams/assignments	10%
Performance evaluation by peers	10%
<i>Notes:</i>	
Late assignments: 0.5 penalty points per day	
Absence and tardiness: 1 penalty point per absence, 0.5 points for tardiness	
Extra credit may be considered for any extraordinary work or achievement	

Table 3: Rubrics for each assessment tool

Assessment tool	Exemplary	Proficient	Developing	Beginning
Preliminary report	Equally conversant with all aspects of the project, even if specializing in one or the other	Covers all aspects of the project, but less able to cover specific project issues	Covers all aspects of the project, but has little concern about the realistic constraints	Merely covers technical developments for the project
Peer evaluation	All members work productively together, cordial resolution of any differences, all members are respected	Group is productive, but one member is somewhat less effective (or perhaps less respected) than the others	Group is still productive, but there is noticeable internal friction	Group has significantly reduced productivity compared to their potential
Homework	Case study of professional ethics is thoroughly covered and understood	Case study of professional ethics is well covered, but the necessity and impact are not properly addressed	Case study of professional ethics is studied, but lacks of proper understanding of the subject	It merely covers the required subject
Project presentation and demonstration	Readily communicates and demonstrates project outcomes to audience	Knows all aspects of the project, but less able to share or demonstrate project outcomes	Knows project adequately, but has little concern about what others want to learn	Presentation and demo are not properly organized and prepared
Project proposal	Clearly address all required technical developments as well as feasibility of the project	Covers most technical requirements and feasibility issues, but doesn't have all details	It covers most requirements of the proposal, but lacks of the detailed justifications	It merely covers basic requirements of the proposal
Prototype development	Comply all minimum success criteria of the project, sturdy and robust, high degree of craftsmanship	Everything meets the project's minimum success criteria, but it has some reliability and operating issues	It doesn't meet one or more minimum success criteria	The prototype doesn't function properly

transducer for measuring wall thickness. Two torsional springs press the sensor against the surface. If the transducer impinges on a bolt head or weld bead when the Spider is going backwards it can cause the wheels to depart from the surface, resulting in a fall. Another situation that can cause the Spider to fall is when the surface transitions to a non-ferromagnetic material, such as when the top of a tower comprises austenitic stainless-steel. To protect the Spider, three improvements were sought by ATS:

- Video of the fore and aft views from the Spider streaming to the operator
- Capability to raise the transducer over obstacles
- Capability to detect non-ferromagnetic surfaces

Minimum-success criteria are developed for the one-semester projects in MTRE 4800. The students, the instructor, and the sponsor collaborated to generate the following requirements for the Spider project:

- The operator must be able to lift and lower the transducer at will.
- While the transducer is in contact with the pipe surface, the transducer contact force must be able to be set between 0 and 1.25 pounds to limit wear from friction.
- The system must be able to detect ferromagnetic pipe surfaces in front of the Spider at a perpendicular distance of 0.3 in, and display this information to the operator on the ground control station (GCS) Human-Machine Interface (HMI).
- The system must be able to communicate with the GCS wirelessly (in compliance with FCC and local regulations) at a distance of at least 125 feet.
- The system must be able to display images on the GCS HMI from the cameras mounted on the Spider with a delay of no more than one second.
- The housing for the on-board electronics must be IP54 compliant (dust-proof and waterproof).

Technical details of the Spider project are presented to highlight the multi-disciplinary aspect of the mechatronics senior-design course. In order for the team's improvements to be used on any of the sponsor's Spider robots, all hardware except for a ferromagnetic surface detector (FSD) was to fit in a single case mounted atop the spider. All improvements are depicted in Figure 2, details of which are discussed as subsystems are described. The team performed FEA analysis of the housing as part of the project's mechanical-design component. See Figure 3. Electrical and software design was also performed.

The team designed the following subsystems: a motor for lifting the thickness transducer, the ferromagnetic surface detector, and one front- and one rear-facing camera. An on-board computer, the ODROID-C2, controls the subsystems and communicates via Wi-Fi with the operator. The team designed the HMI shown in Figure 4 for the GCS. A system overview is provided in Figure 5.

As mentioned earlier, a C1 Spider uses torsional springs to press the plate holding its wall-thickness sensor against the surface to be measured. See Figure 2b for a rendering of this

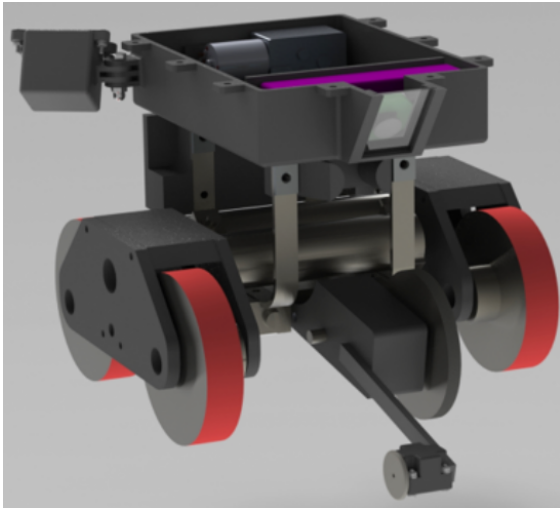

(a) Front view — FSD on distal end of arm

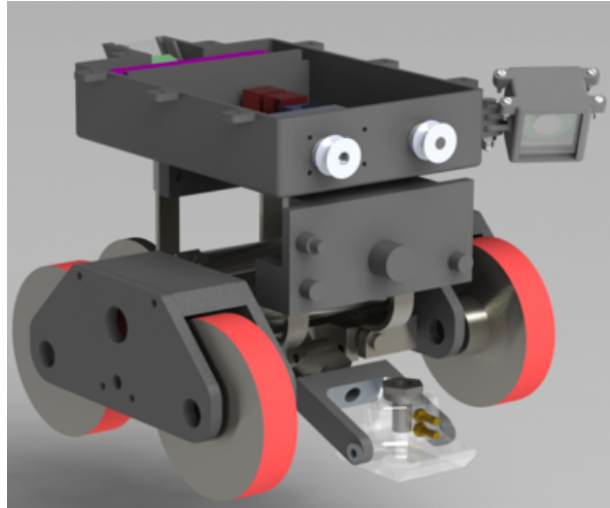

(b) Rear view — thickness sensor on clear plate

Figure 2: CAD rendering of modified Spider

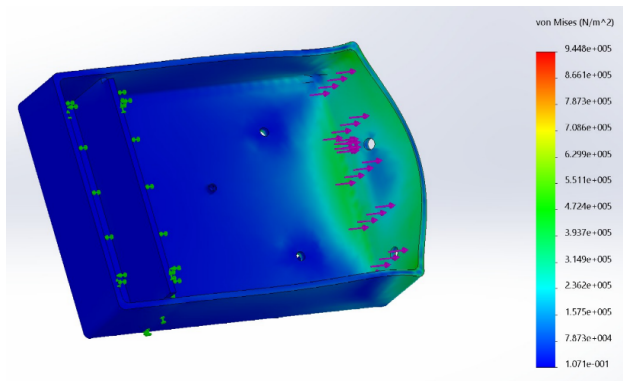

Figure 3: FEA analysis of housing

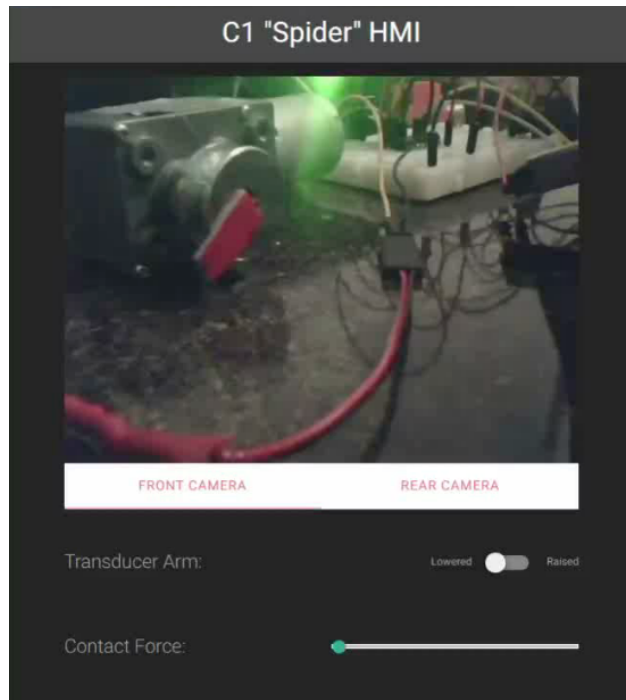

Figure 4: HMI showing camera feed and transducer-arm control

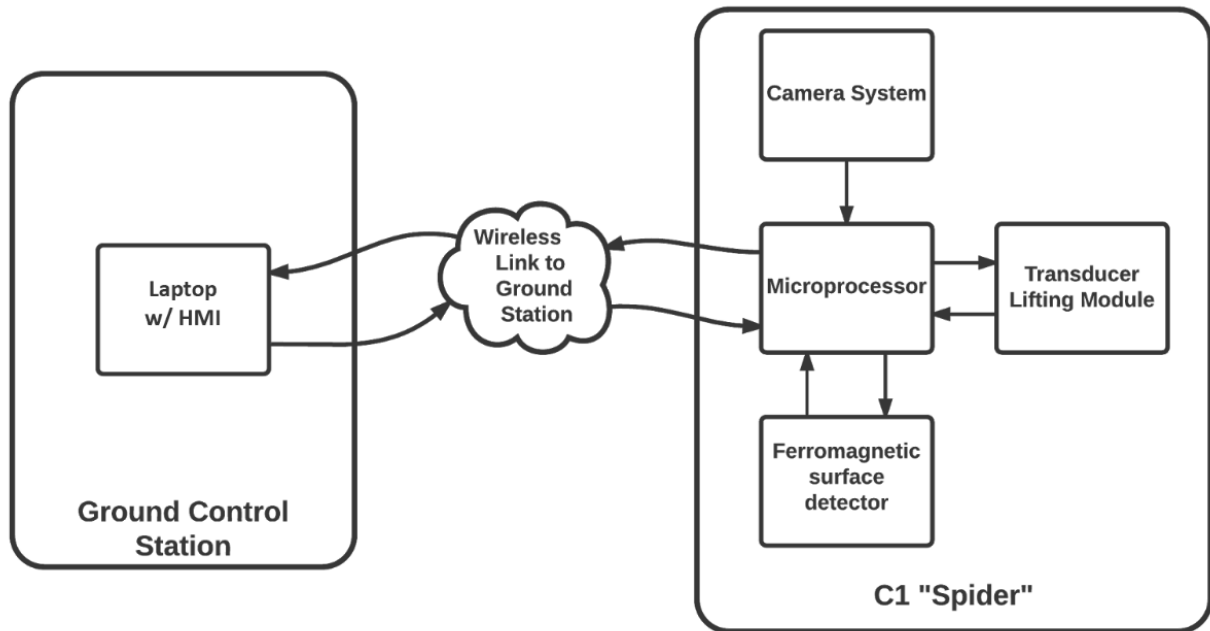

Figure 5: System overview

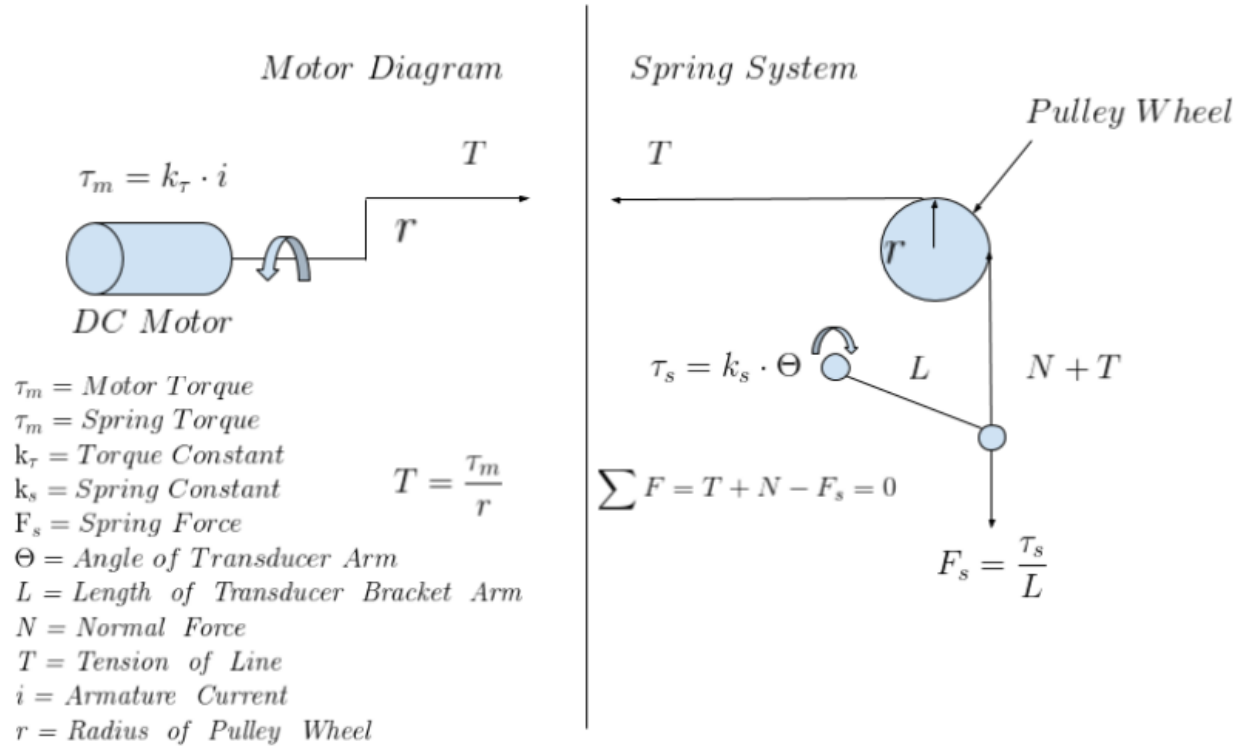

Figure 6: Free-body diagram for motor and wall-thickness sensor

plate and the sensor. The team added a DC motor to counteract this torque and lift the arm. The ODROID-C2 provides a PWM signal for controlling the voltage to this motor. The motor torque, which is used in calculating the transducer contact force, displayed in Figure 4, can be estimated by

$$\tau_{\text{stall}} = \frac{K_t}{R_a} V_a,$$

where K_t is the motor's torque constant, R_a is the armature resistance, and V_a is the voltage across the armature. The free-body diagram used by the team for calculating the resulting contact force is provided in Figure 6.

The custom ferromagnetic surface detector comprises a permanent magnet held above the contact surface by a small wheel. To the bottom side of the magnet (between it and the surface) is mounted a force-sensitive resistor. Its resistance changes as the attractive force between the magnet and the surface varies. The small box at the end of the arm shown in Figure 2a houses the magnet and the resistor. An exploded view of this device is given in Figure 7. The force-sensitive resistor is part of a voltage divider connected to an analog-to-digital converter in the ODROID-C2. A threshold voltage is determined for when a ferromagnetic material is present under the FSD. If this threshold is crossed then the HMI alerts the operator so she can stop the Spider.

The two cameras connect to the ODROID-C2 via USB. They require no additional hardware. The mount for the rear camera provides one axis for view adjustment. The housing for this camera,

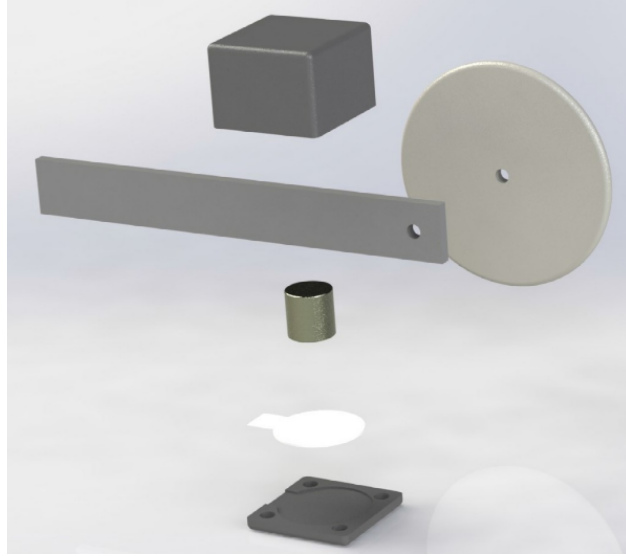

Figure 7: Exploded view of the ferromagnetic surface detector

like the other housing designed by the team, is IP54 compliant. The prototype system mounted on a Spider is shown in Figure 8. This view is comparable to the one shown in Figure 2a.

Assessment of the Spider Project as a Case Study

Feedback from students and the sponsor speaks to the effectiveness of the design process in MTRE 4800. Many of the responses note specific advantages of an industry-sponsored project. Students on the team reported that working with the industry sponsor provided both challenges and rewards. One wrote that the sponsor,

... actively used the spider robot at the time which proved bad and good for us. The downside was there were very few times we were able to have the robot in our possession. The good side of having it very few times was that it forced us to really prove and think out our project in theory within our calculations, CAD, and programming. Therefore when we received the robot the last time we would be ready to go.

Industry-sponsored projects are likely to be useful since they typically serve (to some extent) the sponsor's commercial interests. Student engagement is higher when they clearly perceive the utility of their work. A student on the Spider team evinced this:

The part I enjoyed most was having an immediate real world application to our project.

One of the homework assignments reveals how the course work facilitated meeting some ABET outcomes, which empower graduates to achieve the program educational objectives. Spider-team answers clearly address outcome (a) — *Apply mathematics, science, and engineering to a project:*

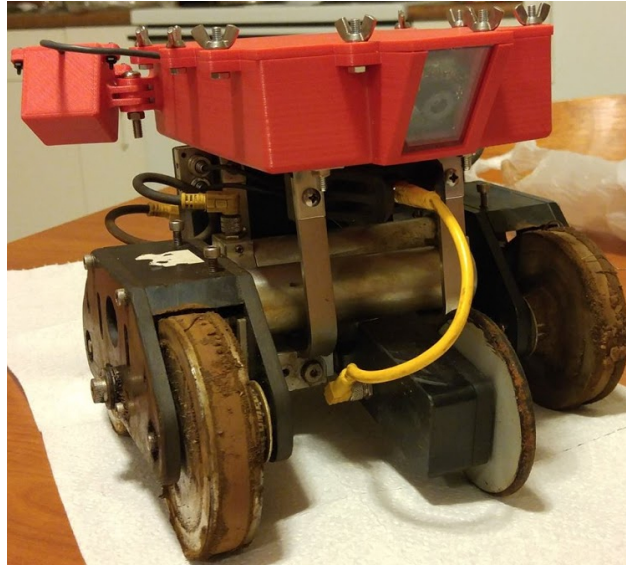

Figure 8: Prototype

The development of the spider project has called for many aspects of previous courses related to mechatronics engineering. Primarily, courses such as statics, dynamics, strengths [of materials], graphics, controls, programming, electric machines and instruments [and controls] have helped significantly. As a result of this course and class, we now have to focus on how these concepts tie together as they would in the engineering world instead of them alone.

as well as (b) — *Design systems, components and processes to meet desired needs within realistic constraints*, and (d) — *Identify, formulate and solve engineering problems*:

... with this class we are given a real world issue which requires us to design and implement a realistic solution.

The students' full course assessments are presented as Appendices B and C.

Working on an industry-sponsored project heightened the students' ability to reach the program objectives. Feedback from the sponsor was solicited after the term, and just as in the student responses, the ability to solve engineering problems was highlighted by the sponsor:

I see this being an opportunity for the students to solve a real world problem using their natural talents and skills/ knowledge obtained from attending KSU. Much like our internship opportunities it allowed the students exposure to a business that routinely hires KSU engineers.

According to the sponsor, the major student outcomes from this project were,

Meeting a deadline, provide a valuable solution to an existing problem, practical experience with the engineering process.

The sponsor also indicated that the industry-sponsored project helped the students with outcome (f) — *Learn effective communications*:

I noticed improved communication with the students by the end of the process.

The students were polled after obtaining and working in engineering positions, in order to gauge the impact of MTRE 4800 on their careers. The responses show that their professional experience reinforces the concepts learned working on the Spider project. Outcome (c) — *Function in multi-disciplinary teams*, was addressed in one response:

... this course has definitely helped me develop essential skills to work efficiently as a team.

Another reinforced the applicability of the industry-sponsored MTRE 4800 project to outcomes (b) and (f):

... the design PDR, CDR, presentations and reports ... were very instrumental in showing how the real world works ... most students fail to realize that working in the future they will have to convey their ideas/projects to other staff like their dept. directors or sales. Also, to prove that their project is even worthwhile to begin, if it's on track, etc.

Conclusions

Using the Spider team as an example, it has been shown that MTRE 4800 is effective in student achievement of learning outcomes that are important both with regard to the program objectives as well as professional development. Team results from applying the course assessment tools show the group's efforts are well-matched with industry design practices. This course incorporates popular and effective pedagogical practices, such as multi-disciplinary work, cooperative learning, and a focus on student engagement.

The Spider project overview illuminates the multi-disciplinary nature of the work performed. The students performed design, analysis, and testing of mechanical, electrical, and computer systems. The course learning outcomes, assessment tools, and grading scale demonstrate that cooperative learning is a key element of MTRE 4800. It was shown that this aspect of the course was enlarged for the Spider team since they worked with engineers at the sponsoring company and sought to help the sponsor meet its goals in addition to those required by the course instructor. Not only did it enhance cooperative learning, but the presence of the industry-relevant project provided by the sponsor also spurred the Spider team's engagement in their project.

Selections from Spider-team self assessments indicate student perception that the course meets its learning objectives. Sponsor feedback presented shows the value of having an industry-sponsored project. Post-graduation surveys describe alignment between the industry-sponsored project and alumni's professional experience. In its current embodiment, MTRE 4800 students are well equipped to meet the learning objectives, and opportunities to work with industrial partners provide further benefit.

References

- [1] N. Hotaling, B. B. Fasse, L. F. Bost, C. D. Hermann, and C. R. Forest. A quantitative analysis of the effects of a multidisciplinary engineering capstone design course. *Journal Of Engineering Education*, 2012.
- [2] T. A. Ward. Common elements of capstone projects in the world's top-ranked engineering universities. *European Journal of Engineering Education*, 2013.
- [3] Robert H. Todd and Spencer P. Magleby. Elements of a successful capstone course considering the needs of stakeholders. *European Journal of Engineering Education*, 30(2):203–214, 2005.
- [4] Alexander Astin and Marcia B. Baxter Magolda. What matters in college: Four critical years revisited. 22, 01 1993.
- [5] R. J. Light. *Making the Most of College*. Harvard University Press, 2001.
- [6] O. Phillips Agboola, M. Hashemipour, F. Egelioglu, U. Atikol, and H. Hacisevki. Assessing a decade old capstone senior projects through abet accreditation program outcomes. *Procedia - Social and Behavioral Sciences*, 47:120 – 125, 2012. ISSN 1877-0428. Cyprus International Conference on Educational Research (CY-ICER-2012)North Cyprus, US08-10 February, 2012.
- [7] *Systems Engineering Fundamentals*, chapter 11. Defense Acquisition University Press, 2001.
- [8] Karl Smith, Sheri Sheppard, David Johnson, and Roger Johnson. Pedagogies of engagement: Classroom-based practices. 94, 01 2005.
- [9] David Johnson. Cooperative learning: Increasing college faculty instructional productivity. *ASHE-ERIC Higher Education Report No. 4*, 01 1991.

Appendix A: Performance of Spider team on key assignments

Assessment tool	Performance
Preliminary report	It clearly defined all technical requirements and specifications for the proposed system development. The introduction of available resources and facilities made sure the project feasibility. It also covered the responsibility of each team member.
Peer evaluation	The result shows that all students recognized each other for their fair contributions to class requirements and prototype development. In particular, students were satisfied with how they were technically complement each other to successfully complete the multidisciplinary Spider system.
Homework	The work thoroughly covered professional ethics through a case study, which also addressed necessity and impact of the compliance.
Project presentation and demonstration	The team's utilization of multimedia was very effective to introduce the project to audience while they demonstrated evidently all project outcomes with a comparison between the existing system and new innovative development
Project proposal	The proposal clearly covered how the Spider project complies with technical requirements of the class. It also ensured feasibility of the proposed project for one semester development.
Prototype development	The team's self-management was successful to keep all milestone schedules while they confirmed their system development through necessary technical analysis and test works. The team complied own minimum success criteria of the project, which was defined on PDR report. The prototype was reliable to demonstrate all functionality.

Appendix B: Spider Team Course-Assessment Homework Submission

1. What contents of previous courses help your development of current project?

The development of the spider project has called for many aspects of previous courses related to mechatronics engineering. Primarily, courses such as statics, dynamics, strengths, graphics, controls, programming, electric machines and instruments have helped significantly. As a result of this course and class, we now have to focus on how these concepts tie together as they would in the engineering world instead of them alone.

The spider project has consisted of four designated areas of design. The first is actuating the transducer over obstructions preventing the crawler from being lifted from the pipe. The design of this system has called for statics and dynamics analysis of the force diagrams. Proper parameters are needed to properly lift the transducer. Then electric machine problems are needed to determine a suitable motor for powering the system. The second objective of detecting if a metal is paramagnetic before the crawler comes calls for further statics and dynamics related problems. A permanent magnet will be pulled down on a force sensor. The third concept of programming brings the microcontrollers to tie the entire project together. Also, this aspect involves electric machines. Lastly modeling the structure of the housing and crawler utilizes engineering graphics and strengths of materials. The material used needs to be strong enough to handle the forces induced by the transducer.

2. What didn't you learn/have to prepare for this class?

The 4 main components of Mechatronics are programming, control systems, mechanical, and electrical engineering. MATLAB and Simulink are both crucial for applying what we have learned in class to real world issues, especially in industry. Though we have been exposed to these programs the foundations could be stronger. This issue has been addressed in newer Mechatronics catalogs with the introduction of MTRE 2610, Engineering Algorithms, however, most of us in senior design are in previous catalogs which are void of MTRE 2610. Another issue is programming, which is also addressed in MTRE 2610 in the form of C+ . Though MTRE 3710 also does an excellent job at exposing students to embedded systems and programming in C, a little more experience would be an excellent addition, helping to solidify the knowledge.

3. How does this class help you to develop your technical skills that you didn't have or were weak before? What are your major learnings in this class?

Before taking MTRE 4800, we mainly dealt with theoretical problems that could be solved by calculations and simulations. And I believe this is one of our greater weaknesses because we were not taught how to implement outside sources in order to solve a problem. Instead we were given equation and step by step solutions to solve the problems. However with this class we are given a real

world issue which requires us to design and implement a realistic solution. That being said, instead of simply doing a calculation to solve the problem we actually have to research more information regarding all of the issues presented; in order to gain a better understanding of what we are trying to create a solution for. Therefore by taking this class we are forced to be self-taught and to research outside of class independently.

4. How does this class help your professional development/readiness? What are major impacts of this class to your professional development/readiness? Both technical and non-technical aspects.

MTRE 4800 introduces the engineering design workflow, from concept to prototype. Often, this can be just as or even more important than the design itself in the real world. A systematic workflow helps to ensure that standards of safety are being followed, and that all parties involved clearly understand the requirements of the design and what will be needed to satisfy these requirements. Through the completion of a semester-long project, we learned the stages of the engineering design workflow, as well as the associated documentation, presentations, and reports that will be required of us in industry. On the technical side, we also learned how to learn for ourselves, and conduct the necessary research to be able to work independently on unfamiliar subjects.

5. How is the evaluation/assessment scheme to make sure the class objectives (development of a multidisciplinary system as a team and professional career preparation)?

The evaluation criteria is less focused on individual technical merit, and instead focuses on teamwork and the overall engineering design process. For example, the evaluation criteria for analysis via simulation is weighted such that it tests not how well a particular system can be simulated, but that we are able to simulate at all as part of the required work in the engineering design process of a multidisciplinary system. As stated in the class slides and by [the instructor] multiple times, the focus should be on making a working prototype, not inventing something new.

Appendix C: Spider Individual Course-Assessment Homework Submissions

1. What are major impacts of this class to your professional development/readiness? Both technical and nontechnical aspects.

This class has provided me with a much better understanding of how engineers design and implement a project. Not only that but, also how clear and detailed an engineer must be when they are presenting their project ideas.

Confidence. This class forced me to work as a group to create something that works. It forced us to use what we have learned to accomplish a task, and where I would normally doubt myself, I did not have that option because others relied on me to get the job done.

MTRE 4800 mostly impacted the way I view working with other people. Everyone has their own strengths and pitfalls. This has taught me further how to effectively work with other future engineers. Secondly I have strengthened my abilities in SolidWorks. Initially I was only able to make basic parts and schematics, but now I can fully make assemblies, complex parts, and perform FEA analysis.

The technical work done in this class actually helped me through the interview process and get me the job offer that I have now. Some of the test questions in the interview were very similar to work that my team was doing for our project. Additionally, the presentations and reports that we had to write have better prepared me for the paperwork and presentations that I will have to do as an engineer in industry.

2. Is there any clear connection between MTRE 4800 and previous courses? Does MTRE 4800 serve as a wrap-up course for your learning and skill sets in the Mechatronics program?

Yes this course pretty much ties in all of our previous learnings and teaches us how to connect the theories with one another and also how to implement them. MTRE 4800 does indeed serve as a wrap-up course because it requires us to build a project that incorporates all of the various subjects that we have learned about.

Yes, though the answer is subjective depending on both the project and the group members responsibilities. Personally, the majority of my previous courses were necessary.

MTRE 4800 is definitely a clear and close connection between previous courses taken with the MTRE program. Additionally extra learning was needed to fully implement our design that was not taught within the scope of the Mechatronic program. For example in my case we are only required to take an entry level graphics design course and my part of the project required learning only taken in following graphics courses.

Yes to both questions. MTRE 4800 nicely ties up all the control systems, electrical, and mechanical work that we have doing in other classes with a physical project.