

Encouraging Diversity through Communication of the Value of our Science and Engineering

Pamela Norris

Changing the Conversation: Messages for Improving Public Understanding of Engineering -- A free online publication from NAE

Math and Science!

**“I want to be an
engineer when I
grow up!”**



What do High School Girls Thinks?

- Engineering is for people who **LOVE** both math and science
- Don't know what it is
- Aren't interested in the field nor do they think it is "for them"

"Someone who excels in math and science.... Someone who is motivated, dedicated, and who doesn't mind sitting in a cubicle all day."



Population and Degrees Awarded by Race/Ethnicity and Gender, 2013

Population, 20-24 Years Old

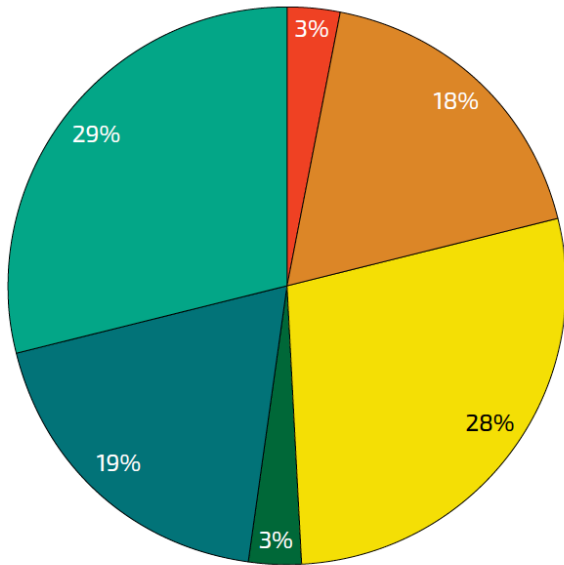

All Bachelor's Degrees

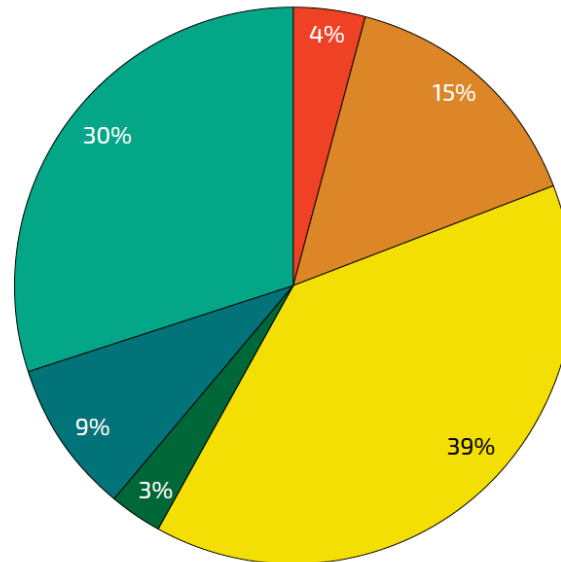

Engineering Bachelor's Degrees

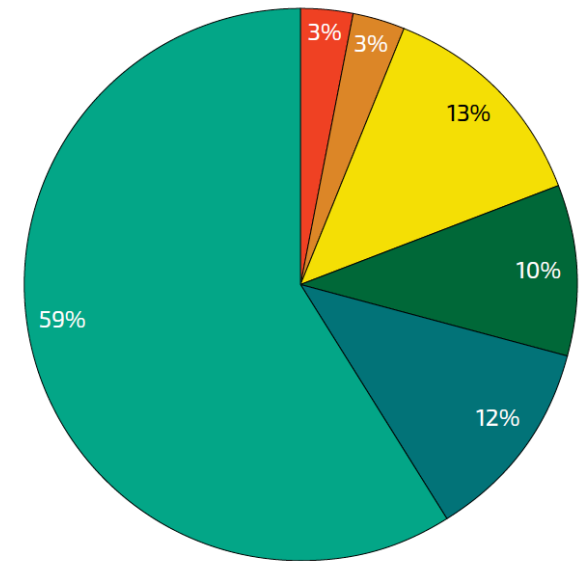

● Asian American women
 ● URM women
 ● White women
 ● Asian American men
 ● URM men
 ● White men



Words Associated with Engineering

software cubedweller
supersmart technology
math smart
don't know science drone
cars internet design
problem-solving
machines innovative
typing trains confusing
cold lonely difficult

Perceived Characteristics of Engineers and Scientists

Scientists

SAVE LIVES

2003	82%
1998	65%

SENSITIVE TO SOCIAL CONCERNS

2003	61%
1998	57%

CARE ABOUT THEIR COMMUNITIES

2003	51%
1998	46%

Perceived Characteristics of Engineers and Scientists

	Engineers	Scientists
SAVE LIVES		
2003	14%	82%
1998	6%	65%
SENSITIVE TO SOCIAL CONCERNS		
2003	28%	61%
1998	46%	57%
CARE ABOUT THEIR COMMUNITIES		
2003	37%	51%
1998	24%	46%

Harris Interactive. 2004. American Perspectives on Engineers and Engineering. Poll conducted for the American Association of Engineering Societies. Final report, February 13, 2004.

Communal versus **Agentic Goals**

- *Serving community*
- *Working with people*
- *Altruism*
- *Helping others*
- *Connecting with others*
- *Serving humanity*
- *Attending to others*
- *Caring for others*
- *Spirituality*
- *Intimacy*



See “Solving the Equation” by AAUW, 2015

Communal versus Agentic Goals

- *Serving community*
- *Working with people*
- *Altruism*
- *Helping others*
- *Connecting with others*
- *Serving humanity*
- *Attending to others*
- *Caring for others*
- *Spirituality*
- *Intimacy*

- **Power**
- **Recognition**
- **Achievement**
- **Status**
- **Success**
- **Financial reward**
- **Self direction**
- **Mastery**
- **Demonstrating skill**
- **Competition**



See “Solving the Equation” by AAUW, 2015

Perceived Communal and Agentic Goal Fulfillment, by Type of Career

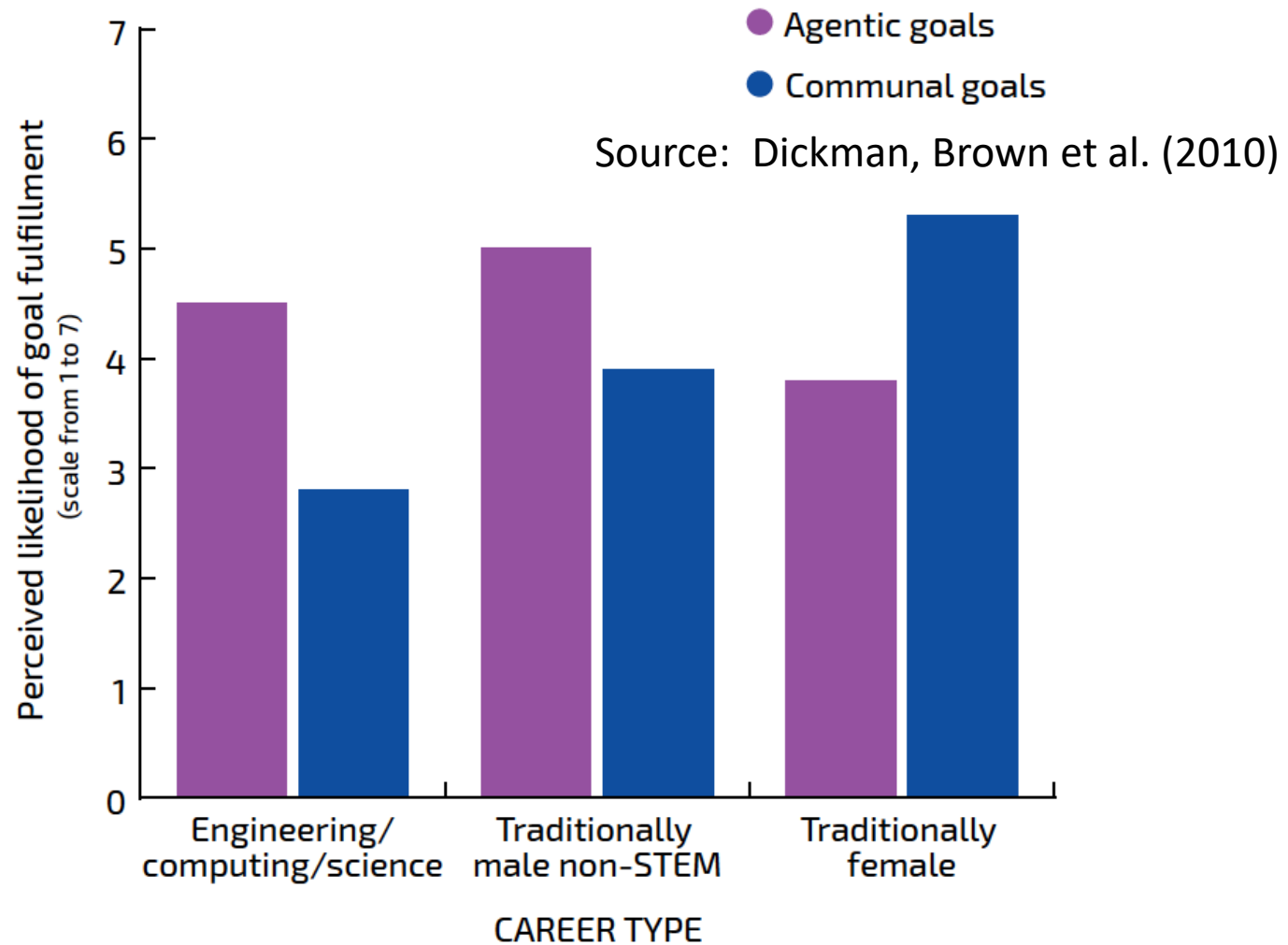

See "Solving the Equation" by AAUW, 2015

Trends in % of Female Terminal Degree Holders

Field	1959-1960	2006-2007
Non-STEM, male stereotypic		
Dentistry	0.80%	44.56%
Medicine	5.50%	49.22%
Law	2.49%	47.62%
Business	1.48%	41.45%

Trends in % of Female Terminal Degree Holders

Field	1959-1960	2006-2007
Non-STEM, male stereotypic		
Dentistry	0.80%	44.56%
Medicine	5.50%	49.22%
Law	2.49%	47.62%
Business	1.48%	41.45%
STEM		
Engineering	0.38%	20.94%
Mathematics, statistics	5.94%	29.76%
Physical science and science technologies	3.37%	31.55%
Computer science and information technologies	2.34%	20.56%

Women's Share of S&E BS Degrees

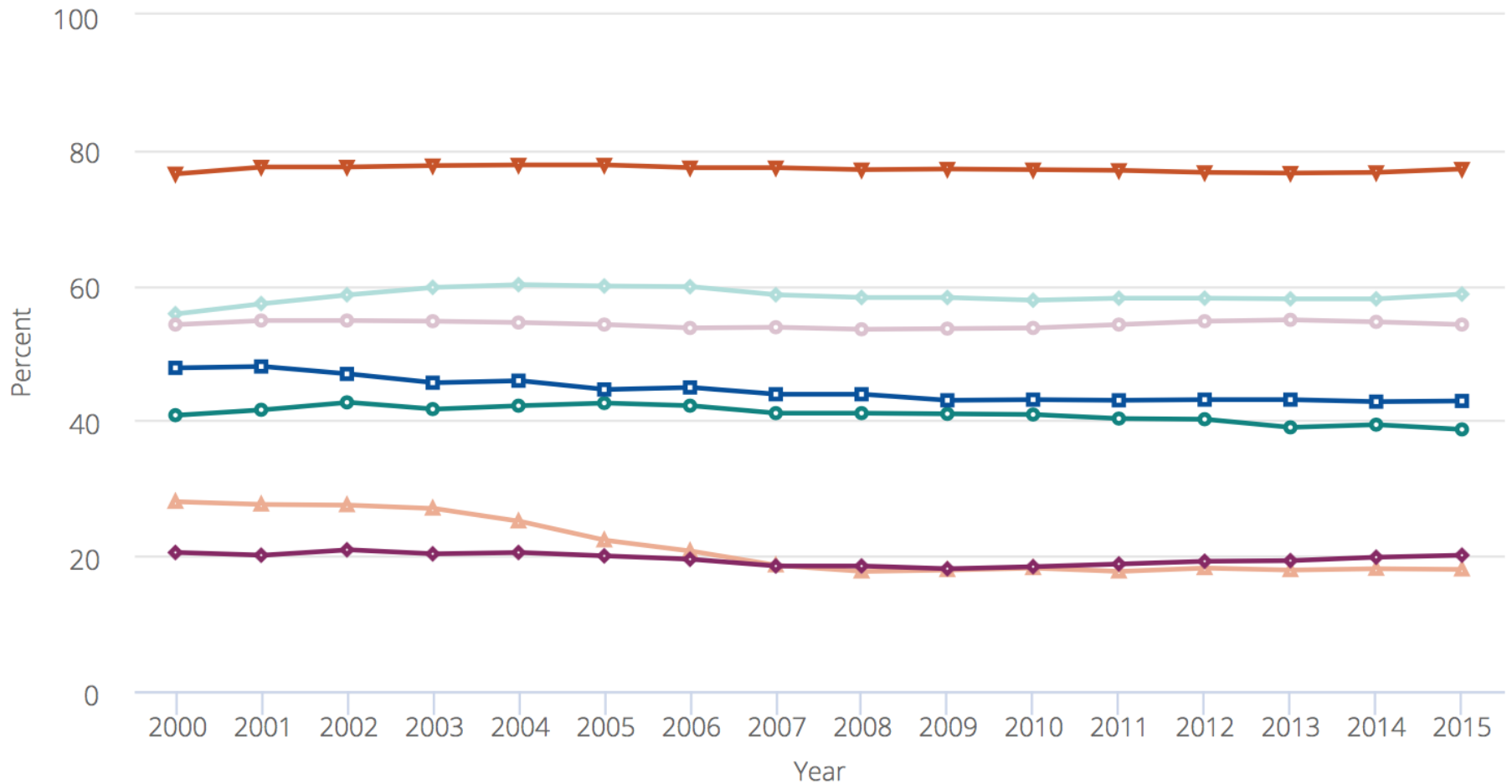

Physical sciences Biological and agricultural sciences Mathematics and statistics
Computer sciences Psychology Social sciences Engineering

Gender Disparities in Engineering

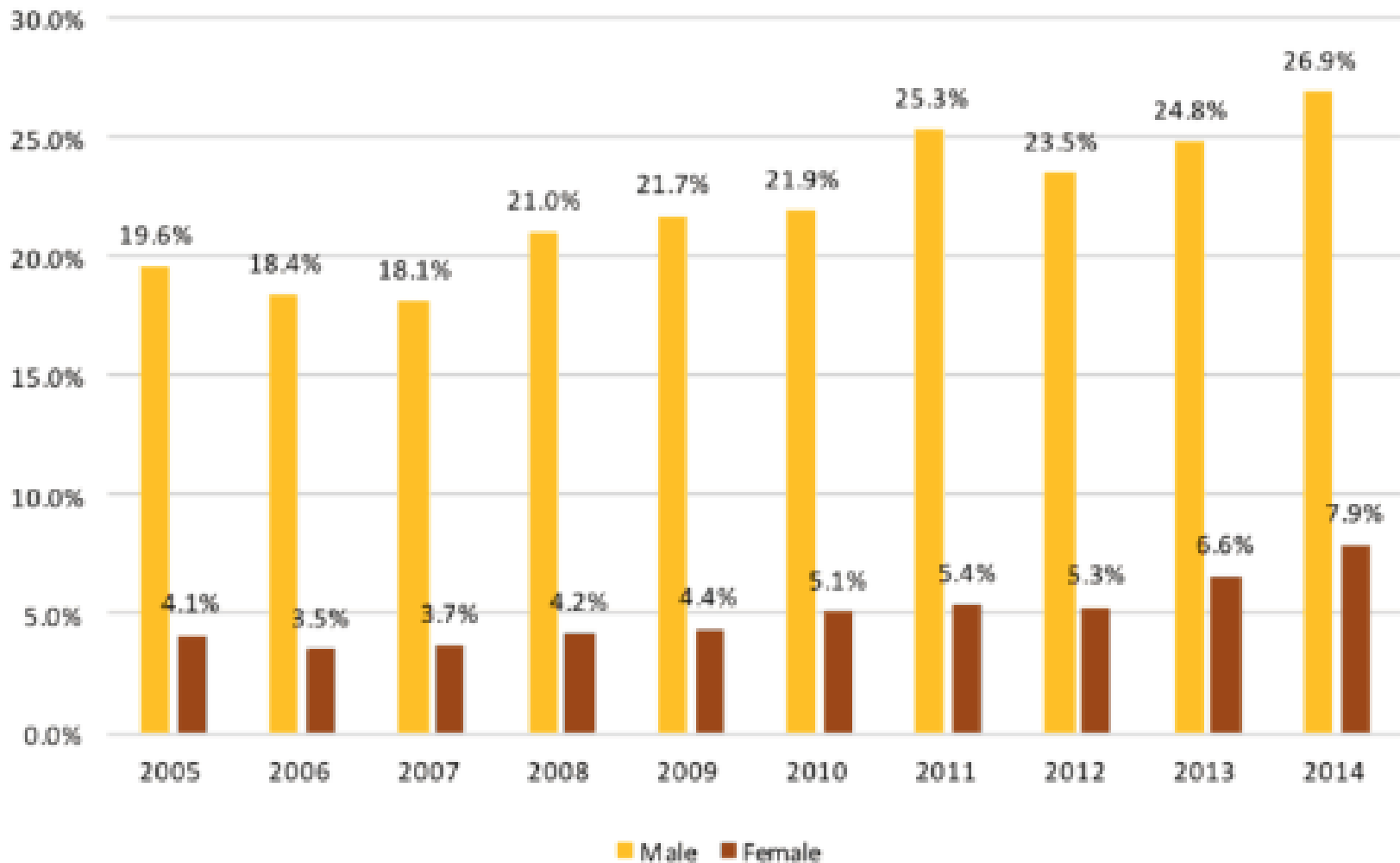

Source: National Science Board. 2016. Science and Engineering Indicators 2016. Arlington, VA: National Science Foundation (NSB-2016-1).

Bachelor's Degrees Earned by Women, Selected Fields, 1970-2013

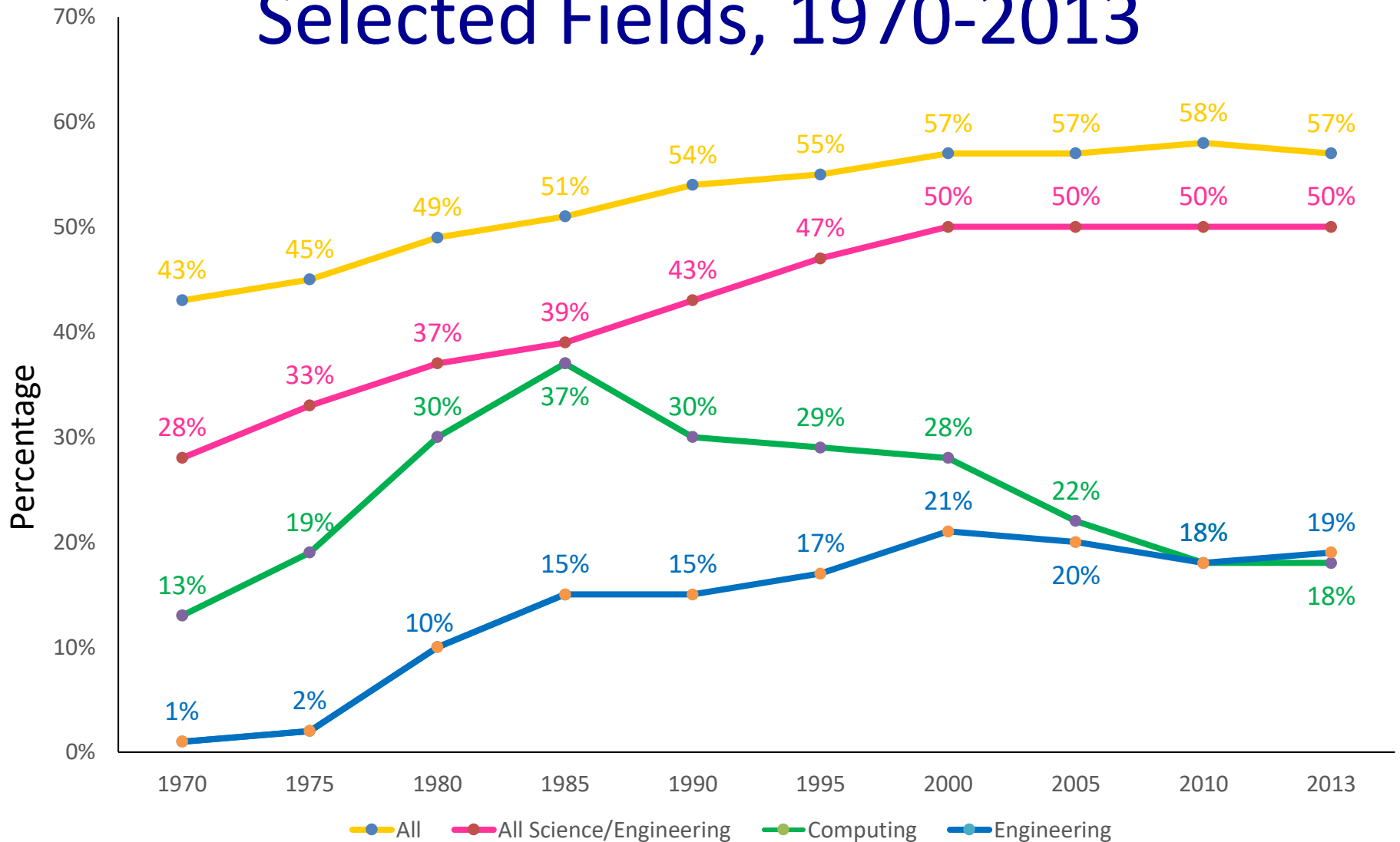

US Percentage of UG degrees in CS and Engineering Compared to other Countries

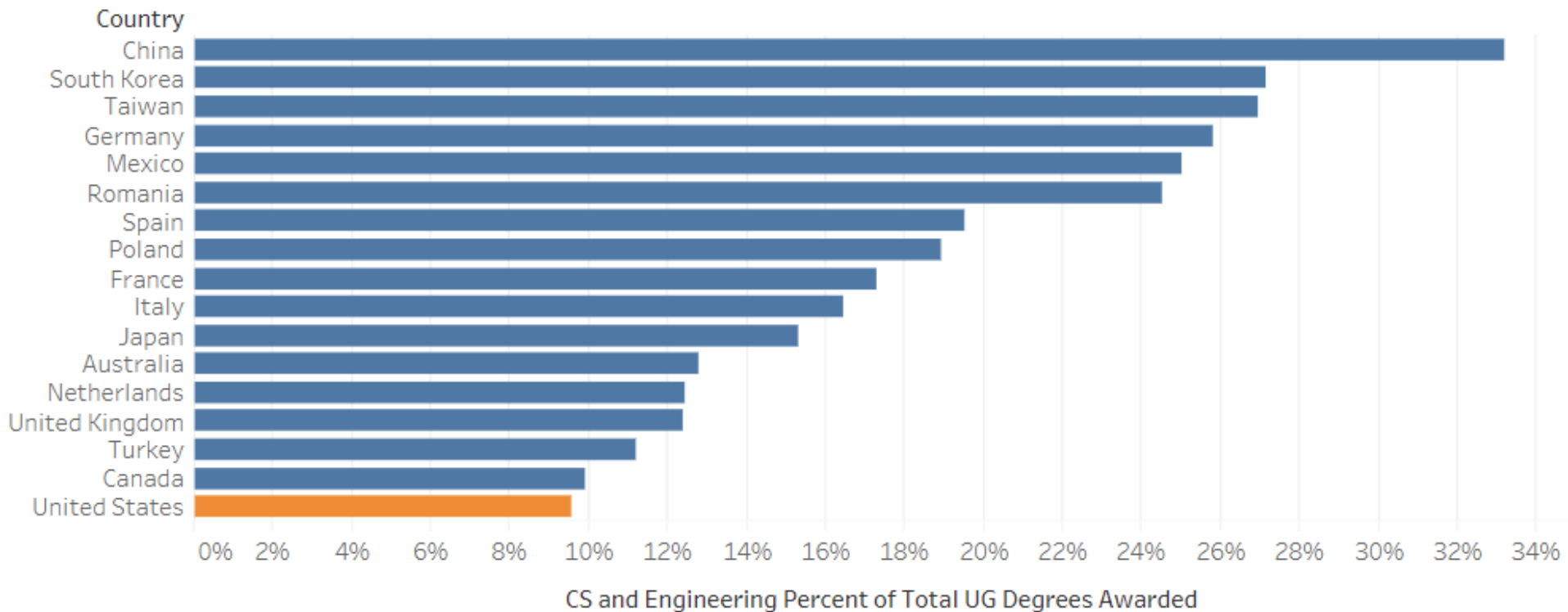

2014 data, National Science Board, Science & Engineering Indicators 2018

And ...Small Portion Earned by Women

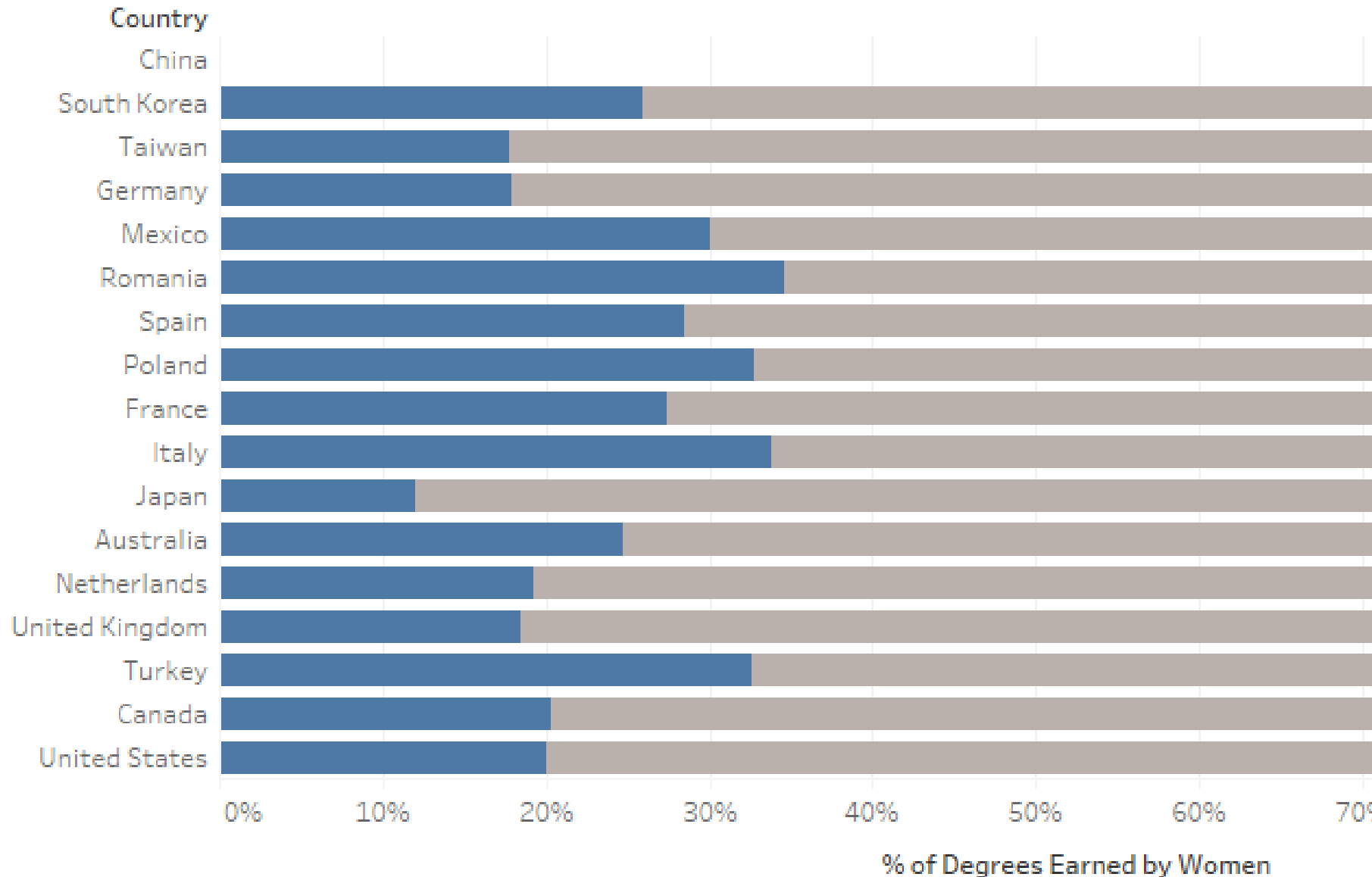

Diversity Can at Times Trump Ability

Diversity Prediction Theorem

Crowd Error =
Average Error - Diversity

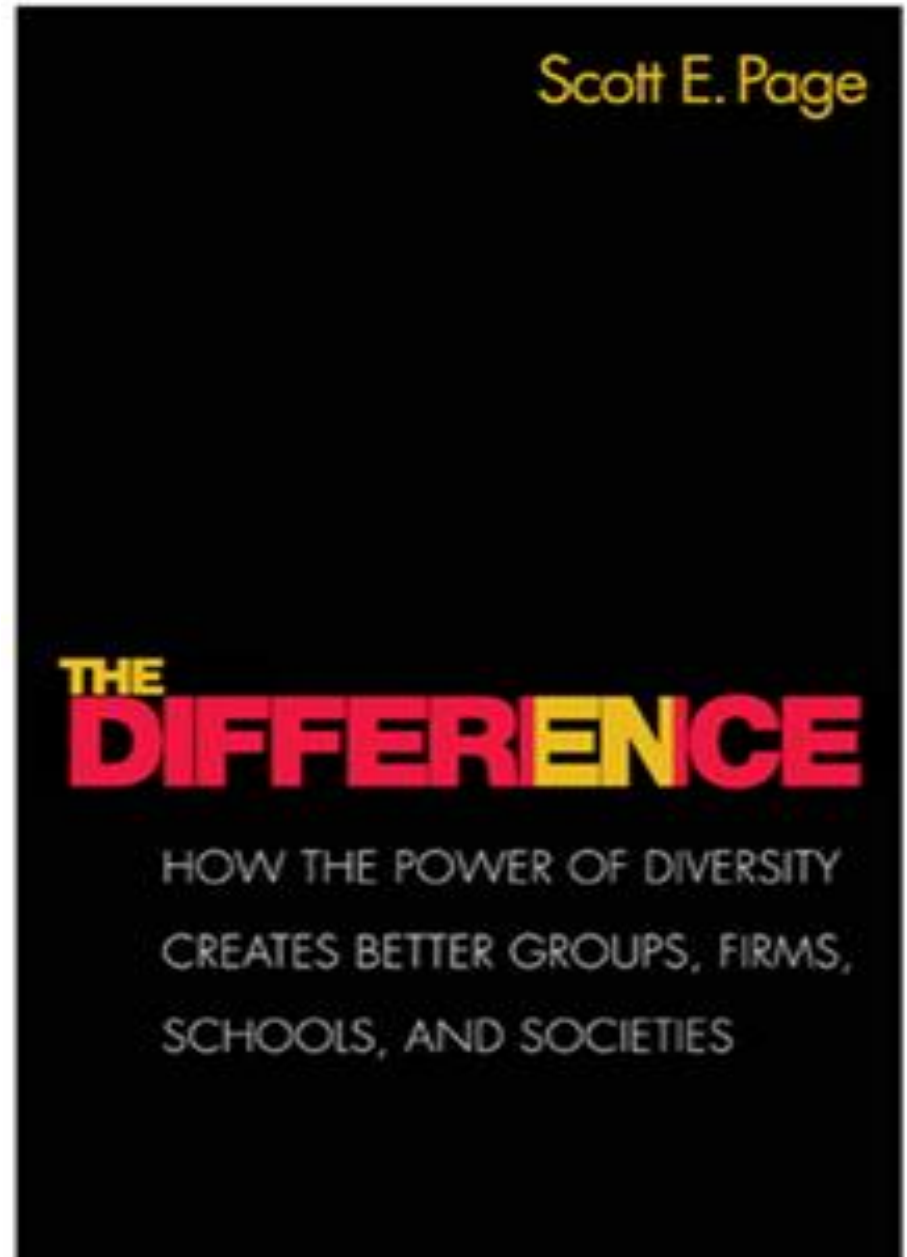



Engineers: It's Time to Change How We Promote the Profession And This Begins with Communication

Committee on Public Understanding of Engineering Messages. 2008. Changing the Conversation: Messages for Improving Public Understanding of Engineering. National Academy of Engineering. Washington, D.C.: National Academies Press.



What CAN WE Say about Engineering

change the world
creativity
collaborative
engineers
contribute
design
rewarding
innovative
flexible
imaginative
help
travel
make a difference
create people
goods salary

Precision vs Accuracy

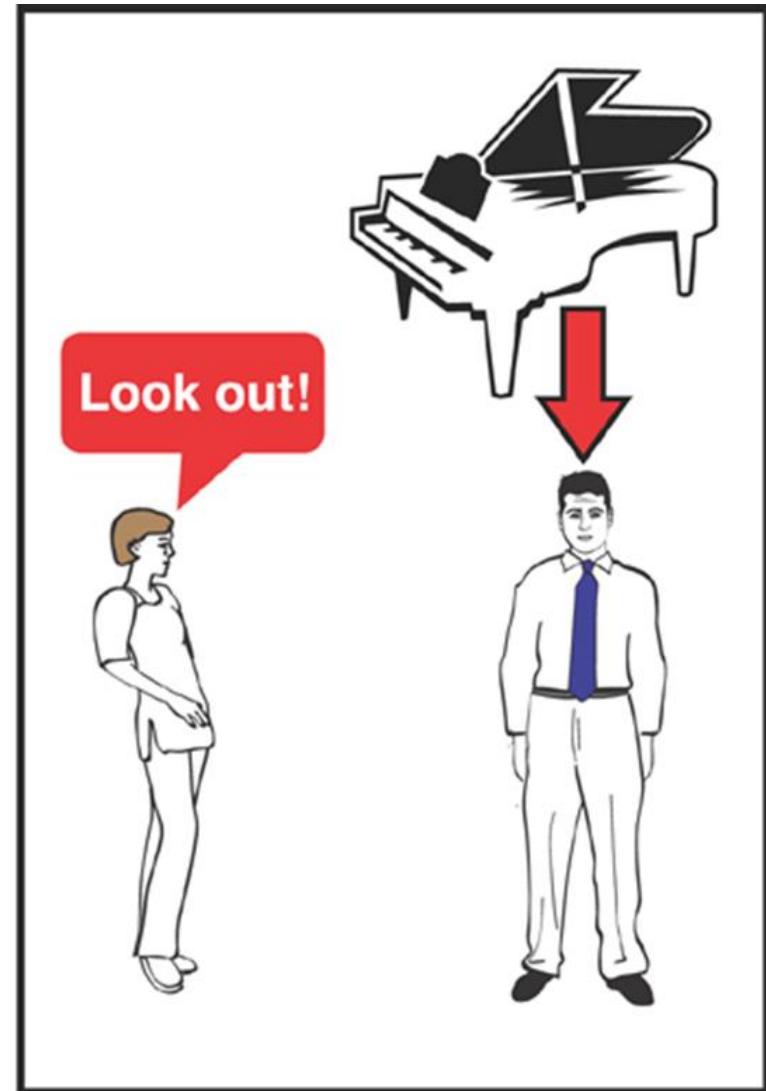
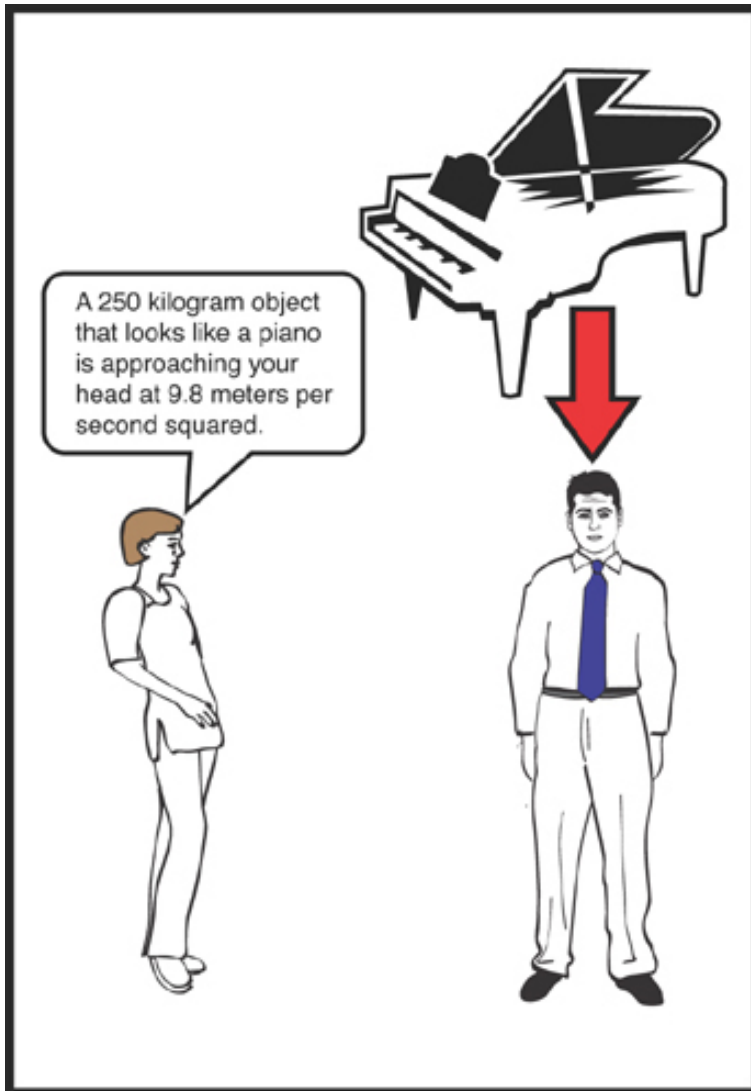

Precision vs Accuracy

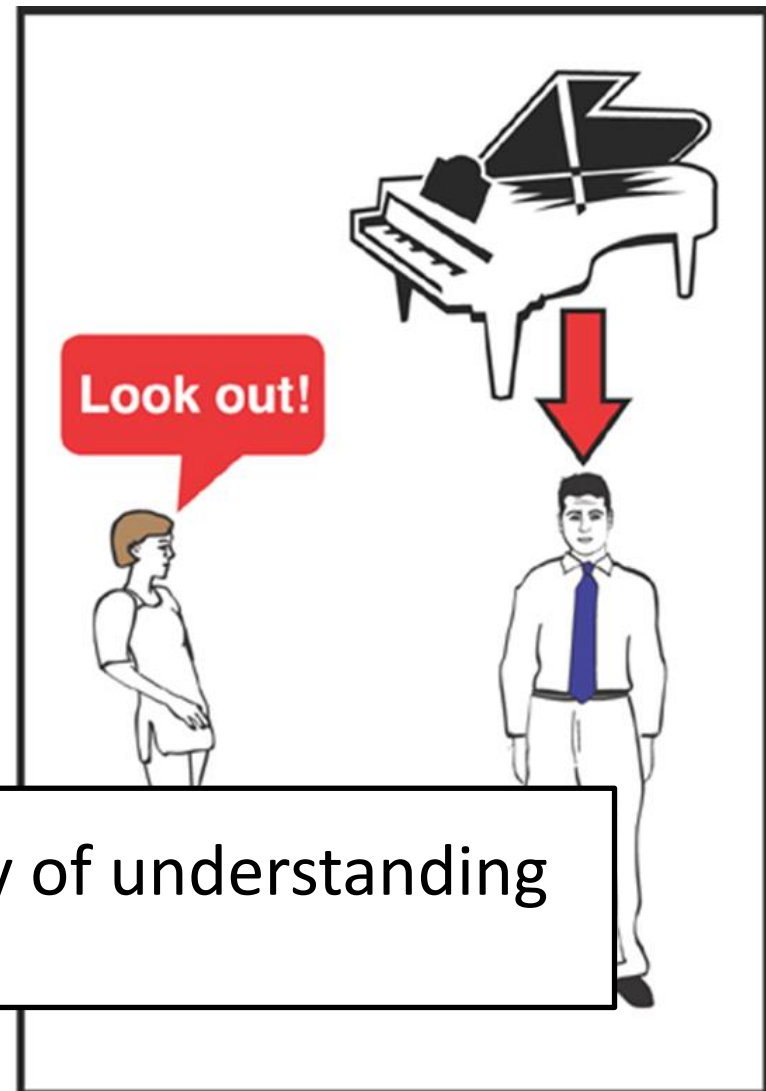
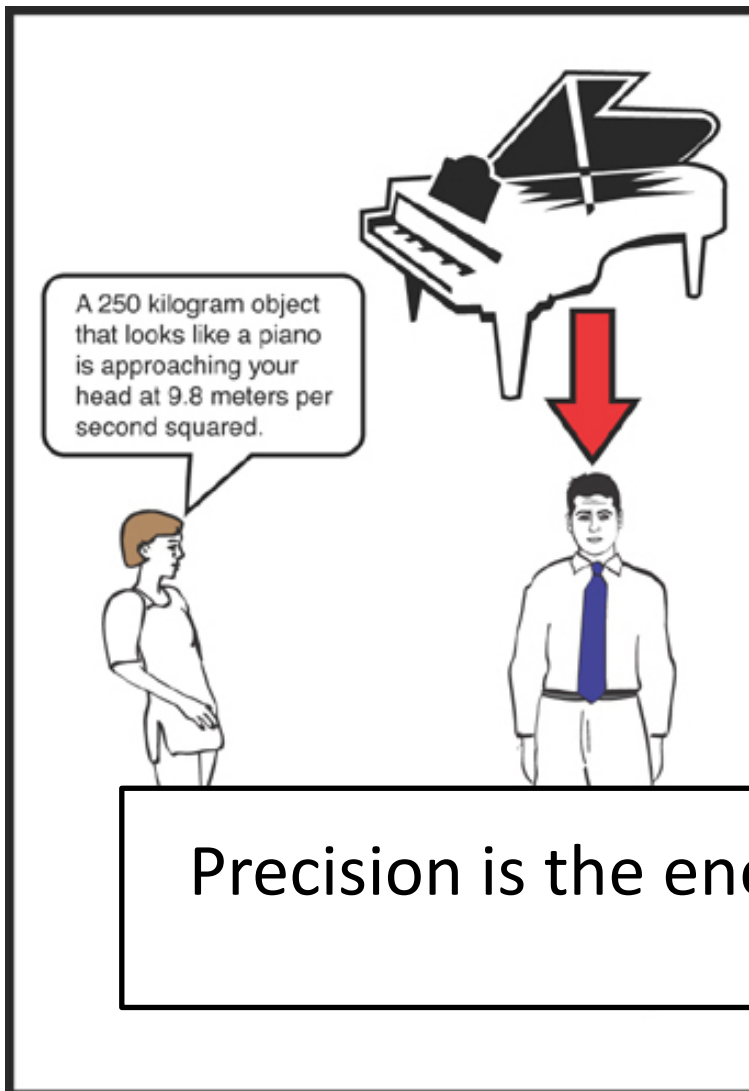

Precision is the enemy of understanding

Precision vs Accuracy: My Own Research

I create superior thermoelectric materials which minimize lattice thermal conductivity via enhanced Umklapp scattering, while maintaining electrical conductivity through high degrees of long range order parameter for high ZT devices.

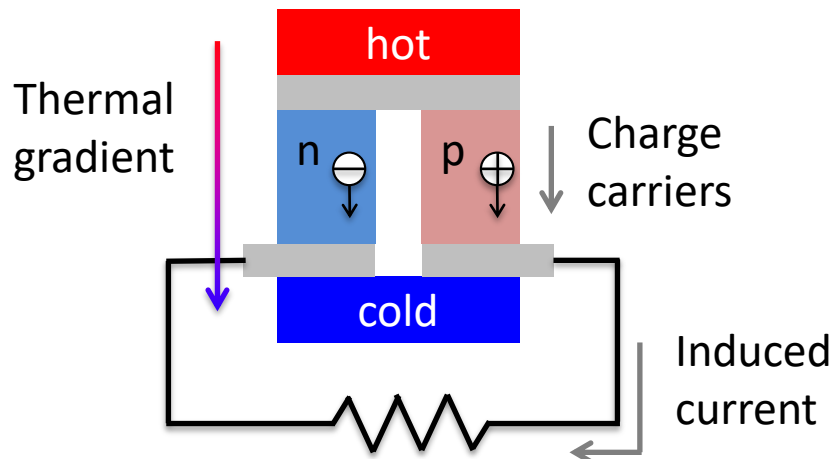

$$ZT = \frac{S^2 \sigma}{k} T$$

My team is looking for ways to convert waste heat to usable electricity by creating highly efficient thermoelectric devices.

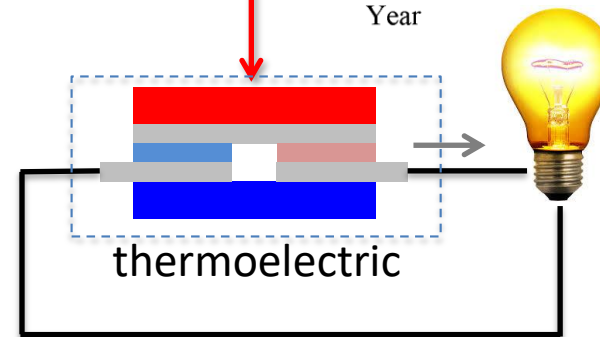
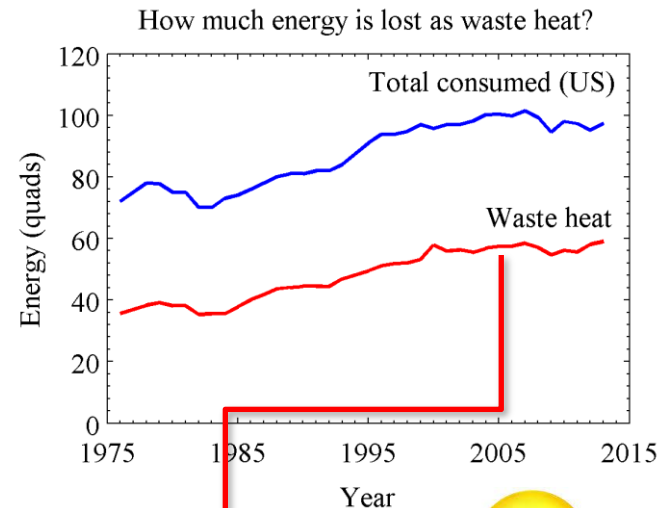

How's This?

Thermal-fluid engineers are changing the world all of the time. They dream up creative, practical solutions and work with other smart, inspiring people to invent, design, and create things that matter, such as alternative energy and clean water.



Engineering is essential to our health, happiness and safety.



Thanks for Listening!

Action

- Tell people how your work makes a difference.
- Change your bio.
- Add a tag to your email signature line.
- Use design or create instead of build.
- Talk about the people you work with.
- Review company or outreach materials—are they using effective messages?
- Check out:

<http://engineeryourlife.org/cms/whyengineering.aspx>

And Changing the Conversation: Messages for Improving Public Understanding of Engineering -- A free online publication from NAE