

## **Collaborative Manufacturing Engineering Education and Research in Japan**

T. Ioi, S. Enomoto, K. Kato, M. Matsunaga, Chiba Institute of Technology, Japan,  
Research Committee of MOT, Japan ,  
Y. Omurtag, University of Missouri-Rolla, USA

### Abstract

This paper describes an emerging engineering education system for manufacturing professionals at Chiba Institute of Technology (CIT) in Japan, based on the principles of industry academia collaboration and case study methodology in teaching and research.

First, the Department of Project Management (DPM), which was established at CIT in 1997 for this collaborative approach, is described. Then, two case studies are introduced illustrating the nature of industry-academia cooperation and the use of real world cases resulting from such cooperation to educate manufacturing professionals for Japanese industries. Our preliminary experiences with this new curriculum and approach to educating manufacturing professionals at Chiba Institute of Technology in Japan since its implementation in 1997 is also presented in the conclusions.

### 1. Introduction

In the past, engineering education in Japanese Universities followed the classical model<sup>(1)-(3)</sup> of lecture methods and laboratory experiments to illustrate and reinforce the basic principles of science and technology. In the new and emerging approach, industrial and international connections and collaborations are emphasized in research and education of the engineering talent to be responsive to the needs of the global and technology driven enterprises of the future.

The first part of the paper describes the DPM that was established at CIT in 1997 for this collaborative approach in engineering education. The curriculum in DPM includes Engineering, Information systems and Management as its main components. The undergraduate students are educated through case studies after developing English language skills, competence in computer technology applications and knowledge of basic manufacturing processes including various technologies. Students are also exposed to the principles and uses of information and management systems. The final goal of the curriculum in DPM is to develop the technical problem and project definition, solution and management skills of the graduates so that they can quickly adopt to the manufacturing or other technology driven project environments as effective team members and leaders.

The second part of the paper deals with the collaborative research projects developed with industry to help students with the education process in the DPM. The first case study deals with a project resulting from an international cooperation between the US and Japan on the clarification and management of the performance of ground support equipment (GSE) for aircraft engines. The second project and the resulting case study deals with the Research and Development activities undertaken by the joint research committee called MOT (Manufacturing On The Table) with partners from industry and academia. The main purpose of the MOT committee is to assist in the development of modern and strategically integrated manufacturing systems with a view to gain competitive advantage in the global economy. Thus the curriculum is intended to impart on the student not only the body of knowledge, skills and attitudes necessary for effective use of technology, engineering and management through cognitive processes; but also experiential learning provided by these examples of actual case studies.

## 2..Manufacturing Engineering Education at the Department of Project Management

Today, many projects that involve planning, development and design are most likely to be carried out by project teams, thus the formation of project teams and management becomes extremely important. Project Management approach is a relatively new way of forming efficient teams by bringing experts in different fields together and by using the given management resources to complete a business project within a specified time. This type of curriculum teaching Project Management skills has not been introduced in Japanese Technological Universities until recently.

The DPM in CIT was founded in Japan to establish the educational program for the first time to prepare such experts. Fig.1 shows the education program at the DPM in CIT. The DPM has three components as educational courses. As the main component, students can select one field out of Engineering, Information Systems, and Management. The others then become the sub-components of the students program of study. Also, the field of Engineering is classified into Manufacturing Systems and Process Systems. Manufacturing systems deals with the project management issues related to the mechanical manufacturing systems such as machining, CIM (Computer Integrated Manufacturing), IMS (Intelligent manufacturing System) and others. Process Systems deal with the project management issues related to the plant operations and other

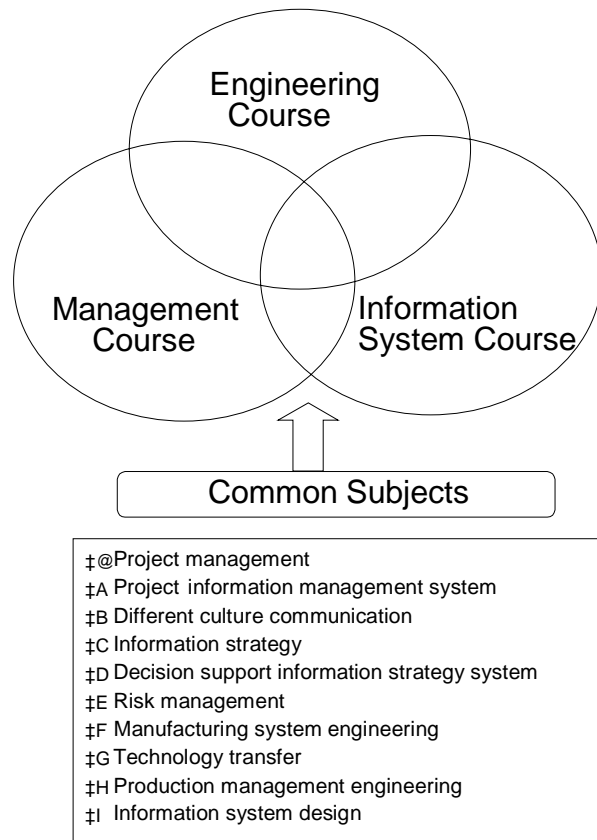

Fig.1 Major Education Subjects for the Department of Project Management

chemical continuous flow systems. A student has to take 50% of his or her credits from the main component and the remaining 50% from other two sub-components. In the curriculum, in addition to teaching basic engineering, the objective is to help students to master the art of business management as well, and to develop their skills of solving problems through the full use of computer systems. Practical educational programs of laboratory exercise and experiments, and test case studies are included. Studies affiliated with Engineering, Information Systems and business Management which are related to project management, or interdisciplinary studies which link these subjects together are also included in the curriculum. Similar education with a broad curriculum based on business management study including technology and information systems have traditionally been included in the Masters of Business Administration (MBA) curricula at the graduate level. However, the educational intent of the DPM education is directed toward mastering both the basic theory and practical experiences of project management by the engineering students at the undergraduate level at CIT.

The outline of the research theme in the DPM is as follows: In the Manufacturing Systems option, it is necessary to develop a new knowledge system related to project management to solve the technical problems. This new knowledge system will be developed by the introduction of systems approach based on the combination of Development Engineering and Systems Engineering concepts, in order to achieve the construction of advanced manufacturing systems with highly precise machining processes and high productivity. In the Process systems option, process creation itself is considered to be the essence of the integration approach corresponding to the individual nature of each project. So, the research objective would be focused on investigating the knowledge system conducive to process creation. In the Information systems, the research objectives are focused on the following four categories: 1) Planning the information system development project, 2) Designing the information system, 3) Assurance of reliability and quality of information system containing cost, and 4) Developing the basic theory concerning the information system construction. In the Management system, the research objective is focused on the analyses of the project forms and the evolution of management thought and practices in the changing society.

### 3. Collaborative Manufacturing Engineering Education

#### 3.1. Manufacturing Education Based On International Development Project

The first case study deals with a project resulting from an international cooperation between the US and Japan on the clarification and management of the performance of GSE for jet engines shown in Fig.2. Fig.3 shows the planned phases of the project. The paper treats mainly the evaluation process as the education item. The project was carried out to secure the technical license for the performance of GSE from the US enterprise. The vibration analysis is a very important factor for the performance of GSE. In order to obtain the formal approvals and recognition the actual performance of GSE must be in conformance with the standard specifications recognized by the US company for such equipment to support jet engines. The Japanese enterprise decided to organize a project team composed of personnel from the University and Industry to submit the analytical results about the performances of GSE within a short period of time of 3-4 months. One of the authors, Prof. Enomoto of the DPM in CIT was selected as the project leader. The simulation and experimental analyses were carried out to get the performances of GSE. In addition to the project management methods

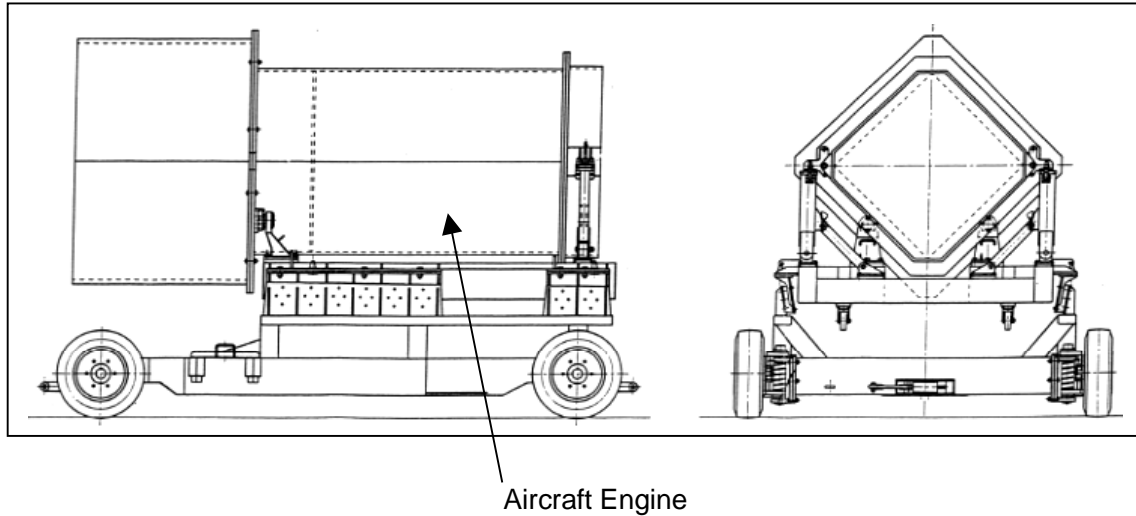

Fig.2 A Ground Support Equipment for Aircraft Engine

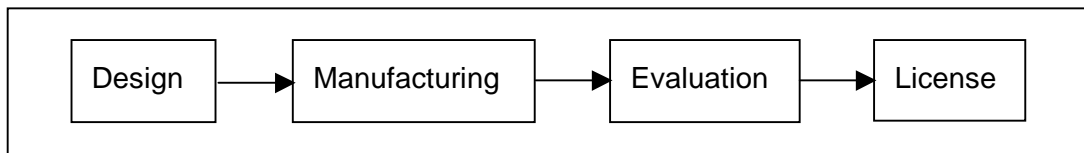

Fig.3 Enforced Process of the Project

techniques of vibration and shock analyses are introduced in the education program of DPM students. Fig.4 shows the implementation processes of the project and the education items relevant to the project.

Process 1 is the starting phase of the project. Here the members who can adapt to the project tasks are selected. The tasks of the project were the simulation analyses using CAE (Computer Aided Engineering), experimental analyses to get the vibration isolation characteristics, and the evaluation for the experimental results. From this experience students can learn the objects of experimental analysis and its procedures, schedule for carrying out the project, methods of experimental analyses, the responsibility for each person, and the selection process of the project team members.

Process 2 is the planning process of the project. Here, the plans for each project team member who is assigned a technical and business management responsibility are made. Specifically, the phase is classified into simulation analysis using CAE, and experimental analyses for vibration and shock of GSE. Thus, a student can study the methods of CAE simulation, experimental methods of vibration and shock analyses, and the planning of technical activities.

Process 3 is the execution phase of the project. In order to perform each planned task of the project, it is necessary to obtain and manage the human and other necessary resources. In this

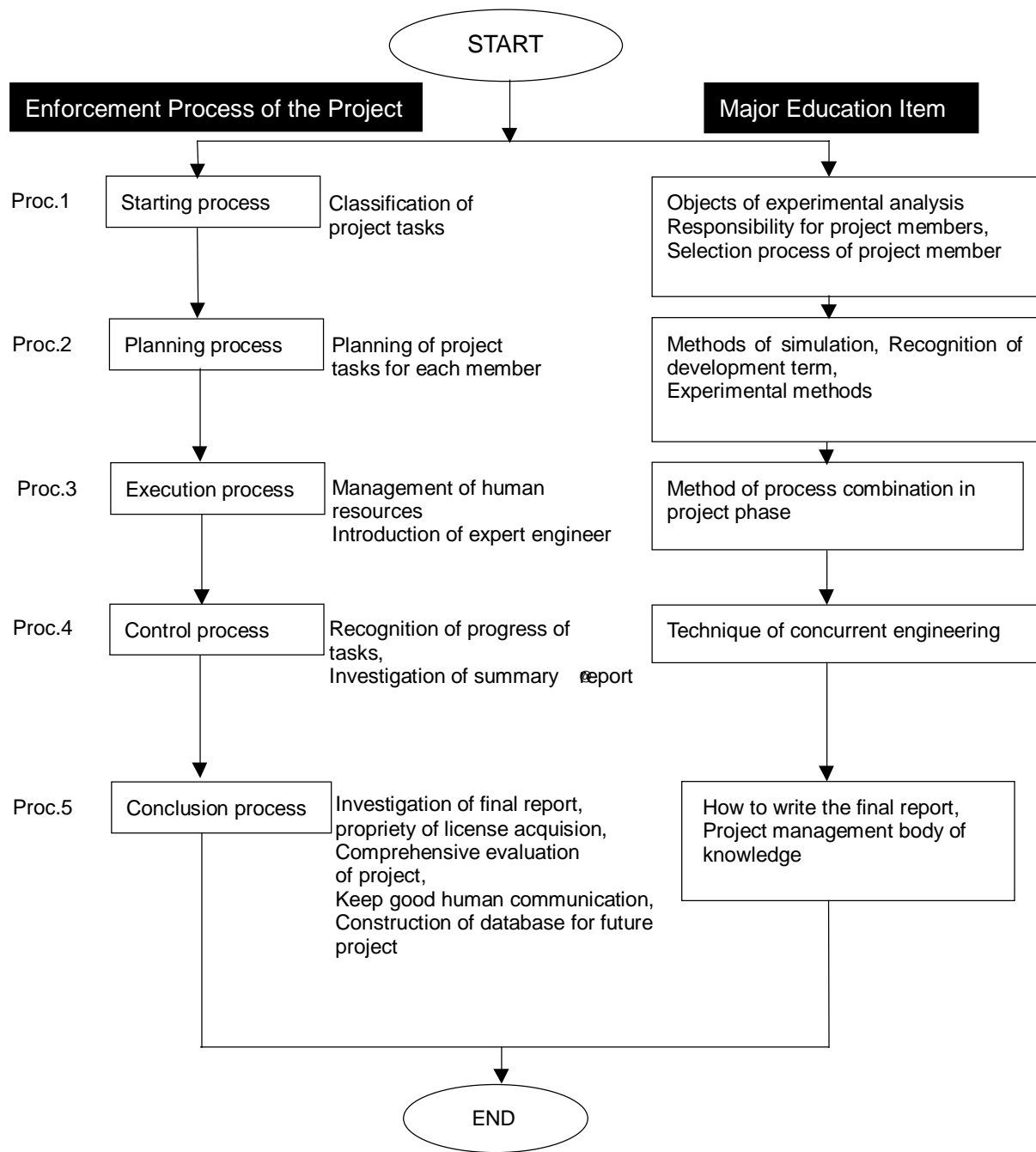

Fig.4 New Education System Related with Industry(Case Study 1)

project it was required that we introduce an expert engineer in order to carry out vibration and shock experiment of the GSE satisfactorily. A specialist in the field of measuring technology was invited to join the project team from the Institute of Industrial Science, University of Tokyo. Through this type of experience, a student can observe and learn the process interactions and interdependencies in accomplishing a project as shown by the example in Fig.5.

Process 4 is the control process of the project. Here, the progress of each project task must be observed and monitored in order to guarantee the achievement of each task. If an improvement

in the execution process is necessary or desired, new ideas can be proposed and adopted by project members. Furthermore, the summary report including the preliminary analytical results of GSE is submitted to the US enterprise, and if some problems to receive full approvals and secure the technical license are pointed out by the US enterprise, they will be analyzed again and additional tests would be conducted if indicated by the project team. Here a student can learn the techniques of the simultaneous processes in project engineering and management also known as Concurrent Engineering practice, and the formal recognition processes between the US and Japanese enterprises.

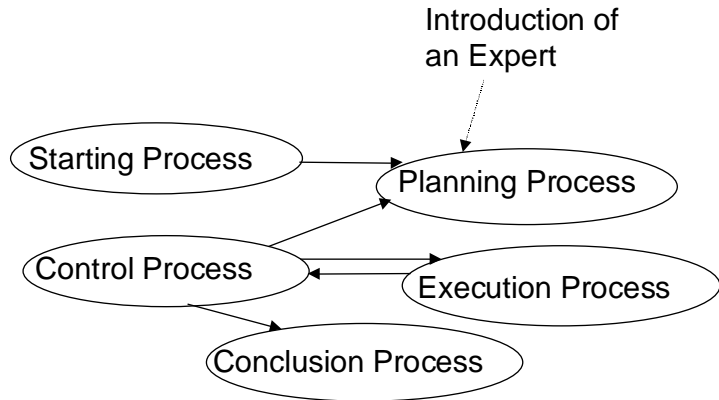

Fig.5 Process Combination of Project Management

Process 5 is the conclusion process of the project. Here, the final report is prepared based on the reports submitted from each project member. The acquisition of the US license for the GSE serves as the ultimate results testing the success of the project. Additionally, it will be reviewed in a comprehensive manner to evaluate whether the management objectives about planning, contract terms, costs, quality, organization, communication, risk, and procurement for the project were achieved as planned. Furthermore, it is also important to keep good human relations and communication among project members for future projects. In this process, a student can learn how to write the final report and other project management body of knowledge as mentioned above.

### 3.2 .Manufacturing Education Based On Research Committee Activity

The second project and the resulting case study deals with the research and development activities undertaken by the joint committee called MOT with partners from industry and academia. The MOT was organized with the participants among University, Industry, and Local Government for developing the small manufacturing system on a table. Fig.6 shows the development process for completion of a new small manufacturing system, and the relevant items of the manufacturing engineering education corresponding to the development process.

Step 1 is the establishment of MOT system concept. The investigation item for the construction of MOT manufacturing system is extracted from the project team using the brainstorming technique. Table 1 shows the practical list of items to be investigated drawn from project members. A student can learn the actual development item, evaluation method, and creation methods for new manufacturing system through the discussions held in such a meeting. The development of MOT serves also as a student's graduation paper topic.

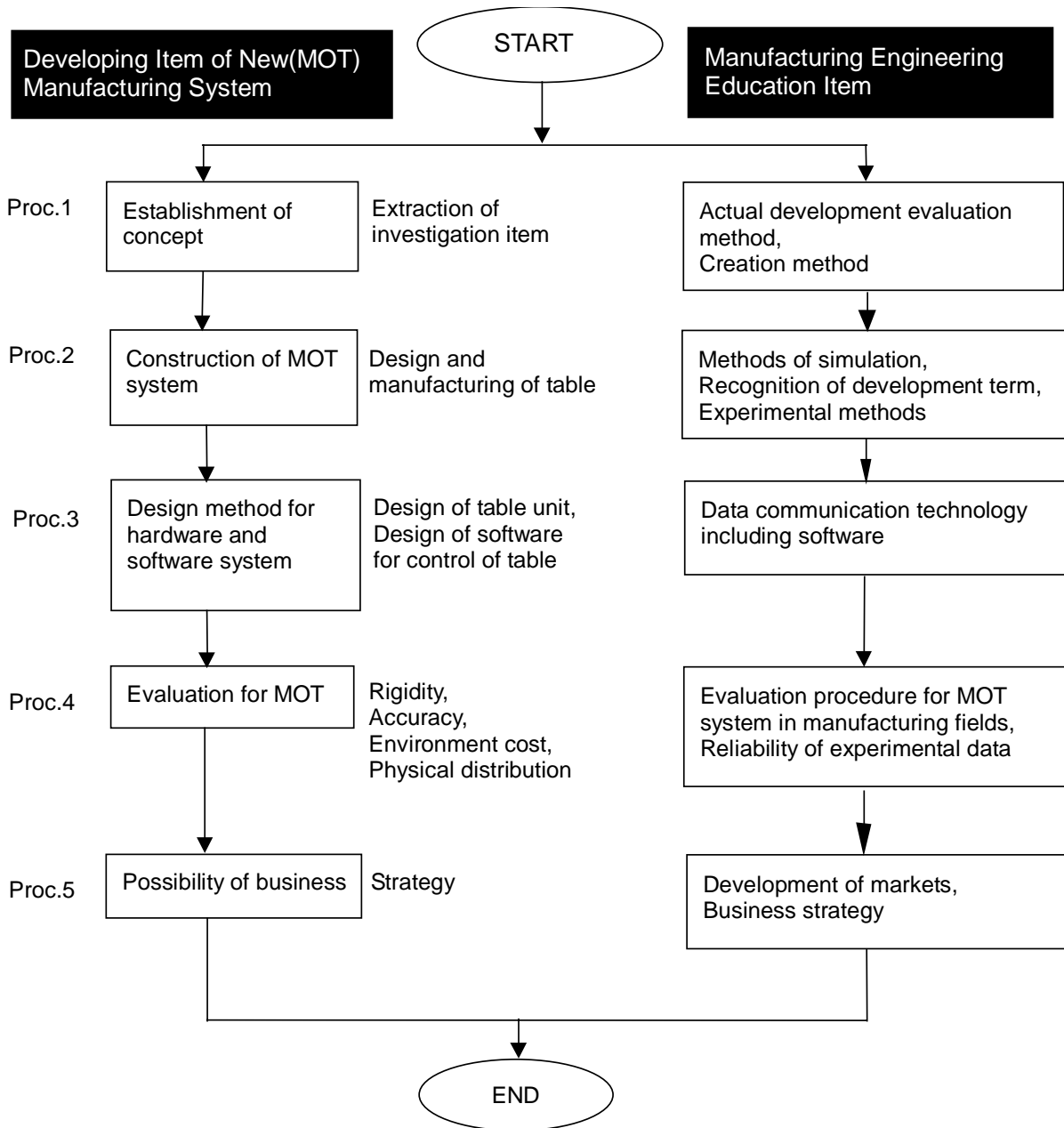

Fig.6 New Education System Related with Industry(Case study 2)

Step 2 is the construction of a MOT system. The design and manufacturing of the “table” are treated as the first development topic by the project team. Fig.7 shows the unit configuration of table<sup>(4)</sup> designed by a student. It is possible to arrange the table unit according to machining, measurement, assembly and other activities pertinent to manufacturing. Furthermore, the table is available to control the manufacturing environment if the manufacturing chamber is set on the table. The table can also have the intelligent functions such as data communication and passive and active vibration isolation ability using different type of sensors and actuators. The MOT

Table 1 Practical Investigation Item for MOT System

Fields	Item
Environment	Energy save function, Recycling, Environment control
Technology	Design of table combination, Intelligent system, Data communication, Small manufacturing
Productivity	Workability, Flexibility, Mobility, Manufacturing cost
Business	Business strategy

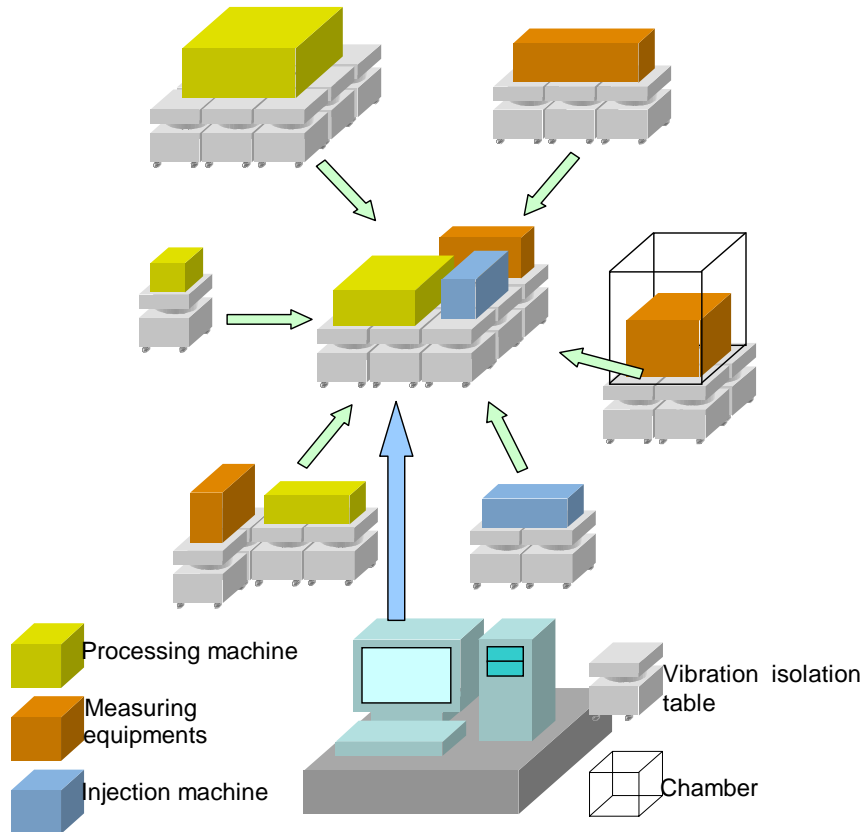

Fig.7 Unit Configuration of Table

manufacturing system is developed for the manufacture of small parts or high technology products. The system also has the advantages from view point of energy conservation, environmental acceptability, public hazard, space utilization, system flexibility, networking function, mobility and workability, compared with the conventional large sized experimental manufacturing systems.

Step 3 is the design method for hardware and software system. The parts manufacturing process on the table is controlled by a personal computer, and the system is also capable of communicating with other production processes. In the MOT system, it is necessary to develop



the network system using an open system, and its software. A student can study the data communication technology in a manufacturing system through the development of a MOT table.

Step 4 is the evaluation for the MOT system. It is necessary to evaluate the rigidity and stability, accuracy, environmental cost and physical distribution for the MOT system compared with the functions of a conventional large size manufacturing system. Through this exposure, a student can experience and learn the evaluation procedure for a small manufacturing system by analyzing the data obtained from MOT experimental equipment.

Step 5 is the examination of feasibility of the business enterprise. This feasibility will be shown on the basis of evaluations resulting from step 4.

#### 4. Conclusions

The conclusions drawn from this research are as follows:

1. A curriculum designed by a collaborative approach between industry and academia may be a good manufacturing engineering education system, because the education environments in the laboratory on campus for students can be converted to the real manufacturing world with positive results.
2. The collaborative manufacturing engineering education may be very effective, because a student can learn the creativity, analytical procedures, and evaluation methods through actual project activities.
3. It appears that the engineering education through project management is an effective education system, because a student can study the technical problems of the project through definition, solution and the body of knowledge for business and management through the applications of theory in a series of real world projects.
4. It appears that the manufacturing education provided through joint research directed by an interdisciplinary committee provides an effective method because through these projects a student can investigate the concept for a new manufacturing system, develop the system configuration, design the methods for both hardware and software systems integration, prescribe an evaluation method for the project, investigate and establish the economic feasibility of business while being involved in a series of real manufacturing system development processes conducted in a team environment.

The curriculum being offered by the Department of Project Management at Chiba Institute of Technology seems to be meeting the manufacturing engineering talent needs of the Japanese manufacturing industry.

## Bibliography

1. T. Ioi et al : Manufacturing Related Education in Japan, ASEE 1995 Annual Conference and Exposition, p1925-1929, 1995
2. T. Ioi et al : Engineering Training for Flexible Finishing System using an Expert System, AEESEAP'95, T-3-5-1~T3-5-4, 1996.
3. T. Ioi et al : Manufacturing Education using Artificial Intelligence, Technology Education, vol.44, No.6, p7-11, 1996 ( in Japanese)
4. K. Kawano : Development of Manufacturing On The Table, Graduation Thesis of Department of Precision Engineering, CIT, 1999 (in Japanese)

## TOSHIHIRO IOI

Toshihiro Ioi is a Professor of Project Management at Chiba Institute of Technology (CIT) in Japan. He has research experiences of twenty years at the Department of Precision Engineering at CIT. Dr. Ioi is actively involved in joint research and developments with many Japanese industries. He got three awards in fields of manufacturing engineering from Japanese Local Government and Society of Research. Dr. Ioi received a B.S. in Mechanical Engineering from the CIT in 1969 and a Ph.D. from the Department of Mechanical Engineering at Nihon University in 1976.

## SHINZO ENOMOTO

Shinzo Enomoto is a Professor of Project Management at Chiba Institute of Technology (CIT). He has many experiences of project management in field of Research & Development in South Asia countries (including Japan). Dr. Enomoto actively involved in International collaboration research with many governments and industries. Dr. Enomoto received a B.S. in Mechanical Engineering from the CIT in 1960 and a Ph.D. from the Department of Mechanical Engineering at National Chiba University in 1989.

## KAZUHIKO KATO

Kazuhiro Kato is a Research Assistant of Project Management at Chiba Institute of Technology (CIT). He received his B.S. and M.S. in Precision Engineering from Chiba Institute of Technology (CIT). He got the best undergraduate student award from CIT, also got the ABTEC(Abrasive Technology) award for the best research paper from Japan Society of ABTEC.

## MASAHISA MATSUNAGA

Masahisa Matsunaga is an honorary professor of Tokyo University. He has lots of research results in fields of Surface Technology, Finishing Technology, Tribology, and Semiconductor Engineering. He was a president of Japan Metal Finishing Society, and he is an honorary president of Research Committee of Burr, Edge and Surface Technology. Dr. Matsunaga received a B.S. degree in the Department of Manufacture of Arms at Tokyo University in 1916 and a Ph.D. at Tokyo University in 1957.

## RESEARCH COMMITTEE OF MOT

MOT means Manufacturing On the Table. The research committee of MOT was established in 1998. MOT committee is studying the concept of small size manufacturing system, construction of MOT, design method for hardware and software, evaluation for MOT, and possibility of business. Members of MOT are K.Amanuma, Y. Itabashi, I.Irie, M. Ota, H. Kato, Y. Kanda, K. Sarada, I. Sakuma, M.Tanaka, K. Maeda, T. Matsushima, N. Morita, A. Yui, and Y. Yoshida.

## Y. Omurtag

Dr Omurtag is a Professor of Engineering Management at the University of Missouri-Rolla where he previously served as the Department Chairman for eleven and a half years. He also served as Department Chair of the Industrial Engineering Department at the Wichita State University and the Middle East Technical University. He has Mechanical and Industrial Engineering degrees from Iowa State University and is a registered Professional Engineer with many years of industrial and international consulting experience.