



Using Service Oriented Remote Laboratories in Engineering Courses

Prof. Hamadou Saliah-Hassane ing., TELUQ -University of Quebec

Professor Saliah-Hassane is a senior researcher at L@d (Laboratory at Distance | TELUQ - University of Quebec), and member of the Ordre des ingenieurs du Quebec (OIQ); of the IEEE Education Society, Communication Society and Computer Society); He teaches informatics and computer networks at TELUQ 1 of University of Quebec. Professor Saliah-Hassane has a PhD in Computer Aided Analysis and Design from the Electrical and Computer Engineering at McGill University in Montreal and a Master of Applied Science degree from Ecole Polytechnique de Montreal. Professor Saliah-Hassane research interest is, among other, Online Engineering Education and Distibuted Systems.

Dr. Mamane Moustapha Dodo Amadou ing., École de technologie Supérieure

Mamane Moustapha, Dodo Amadou received the M.S. degree from the Kharkiv Polytechnic Institute, Ukraine, in 1994, and the Ph.D. degree from the same institute in 2001. Since 2003, he is a lecturer for undergraduate students in the department of Electrical Engineering of École de technologie Supérieure, Quebec, Canada. His research interests are in power systems modeling, simulation, and control, as well as in virtual and remote laboratories.

Dr. Maarouf Saad, Ecole de Technologie Superieure

Maarouf Saad received a bachelor and a master degrees in electrical engineering from Ecole Polytechnique of Montreal respectively in 1982 and 1984. In 1988, he received a Ph.D. from McGill University in electrical engineering. He joined Ecole de Technologie Supérieure in 1987 where he is teaching control theory and robotics courses. His research is mainly in nonlinear control and optimization applied to robotics and flight control system.

Dr. Willie K. Ofosu, Pennsylvania State University, Wilkes-Barre Campus

Dr. Willie K. Ofosu is an Associate Professor of Electrical Engineering Technology at Penn State, Wilkes-Barre, where he teaches telecommunications, wireless systems, networking, optoelectronics and analog and digital electronics. He is a member of IEEE, IET (England), and a Chartered Engineer (CEng) of England. His research interests include RF components and antennas, and Powerline Communication. He is an advocate of diversity in the educational environment. Dr. Ofosu received his Ph.D. from the Electronic Systems Engineering Department at University of Essex in England.

Using Service Oriented Remote Laboratories in Engineering Courses

Abstract

This paper suggests a new approach to perform the laboratories sessions in engineering courses using remote laboratory. Our approach is that for each laboratory session, there are sets of user interfaces designed as services available for the learners. Each service allows applying some inputs (if any) to the physical equipment and returns some selected output signals from the equipment. These outputs signals can be measured and/or saved. In order to obtain the required results formulated by the teacher in his/her learning scenario, the remote learner has to select the services that match the best, and be able to perform all necessary calculations and analysis We refer to this approach as constructional, since, to achieve a given task, the user has to search and choose the appropriate user interfaces designed as services among many others available. The teacher is also able to assess whether the learner has understood the theoretical concepts previously studied in class. The proposed approach is used in a Control System Laboratory session using a DC motor remotely controlled and in Electric circuit analysis course.

Keywords

Online Laboratory, Remote Laboratory, Control System, Service Oriented, Constructional-Approach.

Introduction

During their studies in engineering courses, students carry out simulations and/or real experiments in order to understand or verify some theoretical concepts. The simulations with software tools have a unique benefit in that they can be used by an unlimited number of the students without geographical or temporal limitations. Online laboratories based on simulations are called Virtual Laboratories [1-5]. On the other hand, hands-on/physical experiments require equipment. With the traditional approach of performing experiment directly with equipment, the need for equipment grows proportionally to the increase of the number of students, often resulting in considerable expenses. Following hands-on approach, the only way for universities to share the same equipment is if the students of a other universities are moving physically to a given university to perform their laboratory sessions. We all now know that one way to overcome this drawback is the use of remote laboratories [6-14]. Remote laboratories allow students to access and manipulate real equipment located anywhere in the world through the Internet via a dedicated interfaces, thanks to the development of Information and Communication Technologies. In most proposed remote laboratory work, the users only remotely interact with the real device to change some parameters, perform some calculations and analyze the obtained results.

The main contribution of this paper is to propose an approach which allows the students not only to change some parameters of the dedicated interface of the remote laboratory,

but also apply critical thinking to reconfigure the system to optimize the performance using the available set of service oriented resources for each experiment.

The paper consists of the following sections. Section 2 gives the description of the proposed approach. Section 3 illustrates the application of the proposed approach using a DC Motor control experiment, and circuit analysis, and finally conclusions are drawn in section 4.

Proposed approach

With the traditional approach, generally the experiment session results in systematically performing predetermined steps and then analyzing the obtained results. The proposed approach is different, allowing students to select by themselves the appropriate services for a given experiment in order to perform the required tasks set in the teacher's learning goals. The flowchart of the proposed approach is shown in Figure 1.

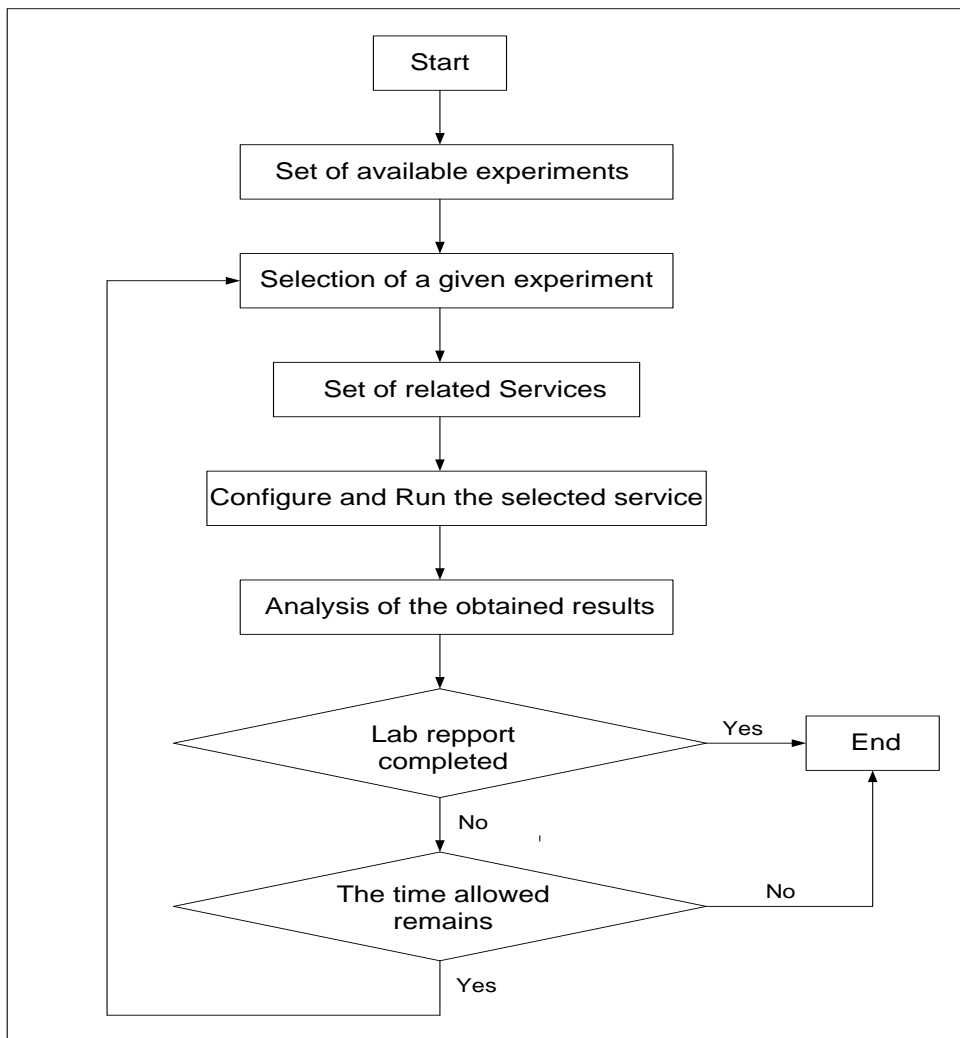

Fig. 1. Flow chart of the proposed approach

As one can see from Figure 1, there are the following main steps:

- 1) **Set of available experiments:** All currently available experiments are displayed.
- 2) **Selection of a given experiment:** At this step the user selects a given experiment among the available experiments. Usually this selection is imposed by the teacher.
- 3) **Services related to the selected experiment:** For each experiment a set of services is available.
- 4) **Selection of a given service:** Ordering selection of some or all services to be executed will allow achievement of all goals fixed by the teacher. Before executing the next service, it is sometimes necessary to calculate some parameters from the results obtained from the previous services.
- 5) **Configure and run the selected service:** Only one service can be executed at a time. Generally, in this case the service configuration is limited to choosing appropriate inputs values in the interface of the service. After the execution of the service the related outputs parameters will be available. If necessary the service can be executed again and again.
- 6) **Analysis of the obtained results:** Before putting the results in the lab report, it is sometimes necessary to analyze the adequateness of the obtained results.

We used LabVIEW™ 2013 Service Oriented feature to implement all the programs controlling the real processes.

The generic interface of each service consists of:

- The remote panel that is the front panel of the VI (a LabVIEW Software component) viewed in a web page [15]. The remote panel has the same functionality as the front panel.
- A live video to watch the real process when the service is running. This is to imitate the traditional experiment session. For example for the DC Motor Control experiment which will be used as case study in section 3 of this paper the user can watch the rotation of the motor during the execution of the service.
- A link to go back to all services of a given experiment. This link is useful, since generally to achieve required goals of an experiment session it necessary to use several services.

Experimenting with the proposed approach

The proposed approach is applied to an experiment called "DC Motor Control Experiment". The setup used for this experiment is a QNET™ DC Motor Control Trainer acquired from Quanser™ shown in figure 2.



Figure 2. QNET™ DC Motor Control Trainer.

This type of the experiment is proposed to the undergraduate students in control systems course in an engineering school in Montreal, Quebec, Canada.

For this experiment the following services are available:

Service 1: Open Loop Response. With this service the user first selects the voltage to apply to the motor. The amplitude of the applied voltage is limited to a given interval. After selecting the applied voltage the user pushes the Start button and the motor's speed variation is displayed on the graph. The motor runs for 2 seconds and stops.

Service 2: Closed Loop Response with P Controller. With this service the user first selects the desired speed reference, calculates the gain value (G_p) of the proportional controller depending on the desired performance and pushes the *Start* button. The motor's speed variation will be displayed on the graph. The motor runs for 3 seconds and stops.

Service 3: Closed Loop Response with PI Controller. This service is the same as Service 2 but the user needs to calculate and then set the gains G_p and G_I of the proportional integral controller.

Service 4: Closed Loop Response with PID Controller. This service is the same as Service 2 but the user needs to calculate and then set the gains G_p , G_I , G_d of the proportional integral derivative controller.

To understand how these services are used, assume that the teacher provides the following learning scenario.

Learning scenario and Lab Report (From the teacher)

Use the DC Motor Control Experiment to determine the value of the gain G_p that allows reaching a steady state error (ess) equal to 15% when the reference speed is a step signal of amplitude 150 rad/s. The setup has the following block diagrams:

The block diagram of the DC Motor in open loop is:

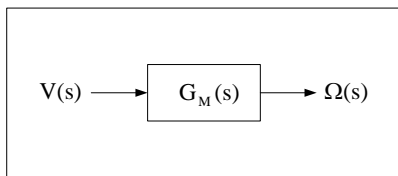

Figure 3. Block diagram of the DC Motor in open loop.

$V(s)$ and $\Omega(s)$ are the Laplace transforms of the applied voltage to the motor and speed respectively, and $G_M(s)$ is the transfer function of the motor.

The block diagram of the DC Motor in closed loop is:

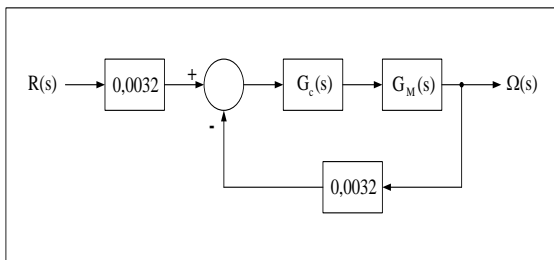

Figure 4. Block diagram of the DC Motor in closed loop.

$R(s)$ and $\Omega(s)$ are the Laplace transform of the reference speed (desired speed) or and actual speed respectively; $G_c(s)$ and $G_M(s)$ are the transfer functions of the used controller and motor respectively.

Indicate in the lab report all services and computation procedures used to achieve the set goal.

Provided Lab Report (From the student)

Determination of G_p

The steady-state error e_{ss} for a step input is determined by [16]:

$$e_{ss} = \frac{1}{1 + K_p} \quad (1)$$

Where K_p is the position constant error.

According to the requirement we need $e_{ss} = 15\%$ (0.15). From equation (1) the required value of K_p is 5,666.

Now determine the expression of K_p from the block diagram of the system in the closed loop. The controller is a proportional one with gain G_p , $G_c(s) = G_p$. In this case the block diagram of Figure 4 can be reduced to the following block diagram with unity feedback:

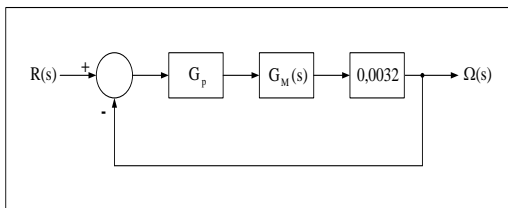

Figure 5. Block diagram of the DC Motor with unity feedback

From Figure 5:

$$K_p = 0,0032G_p \lim_{s \rightarrow 0} G_M(s) \quad (2)$$

For the sake of simplicity let:

$$K_{ss} = \lim_{s \rightarrow 0} G_M(s) \quad (3)$$

Taking into account (3) and the required value of K_p :

$$G_p = \frac{5,666}{0,0032K_{ss}} \quad (4)$$

K_{ss} is called a steady state gain of the system. It is defined as the ratio of the output (speed in this case) value in steady state to the input value (applied voltage to the motor in this case). The procedure to determine K_{ss} is illustrated in the subsection below.

Determination of K_{ss}

Based on the definition of K_{ss} , the Open Loop Response service is the only service which allows reaching this gain. The screenshot after configuring (Setting the applied voltage in this case to 4,5 Volts) and running the service is shown in Figure 6.

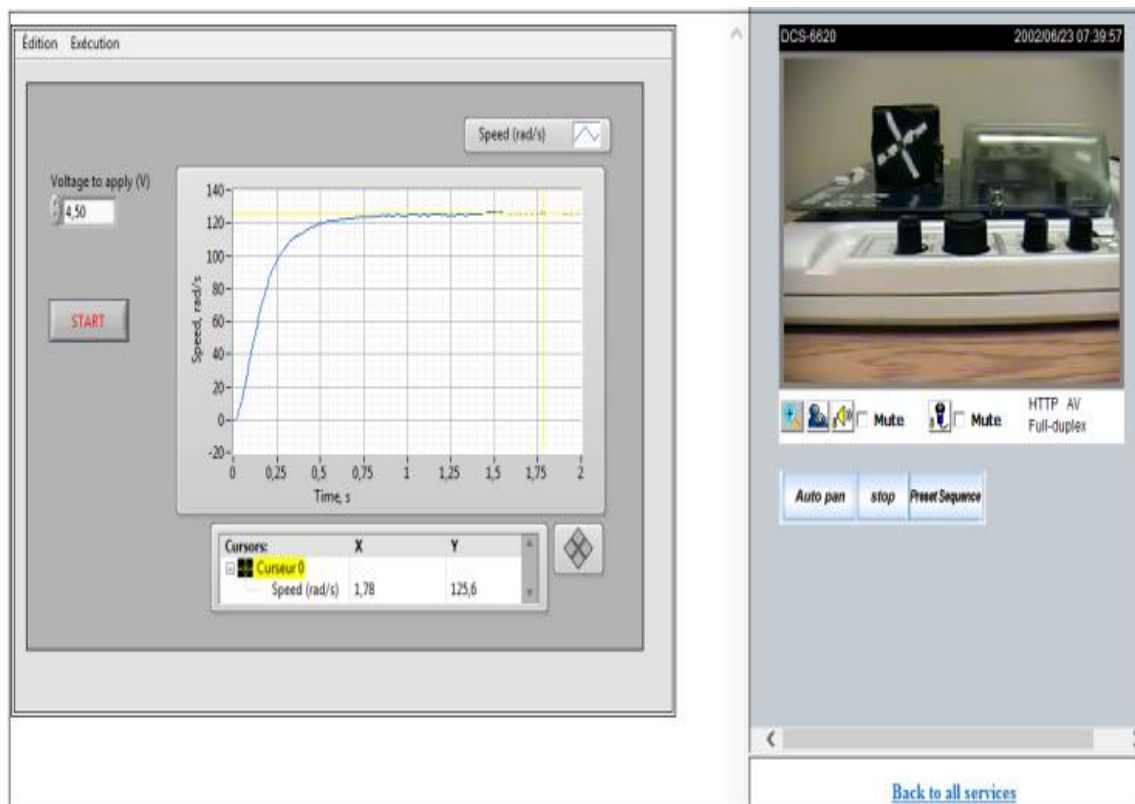

Figure 6. Interface of the Open Loop Response Service

The steady state gain is determined by the following:

$$K_{ss} = \frac{\omega_{ss}}{V} \quad (5)$$

Where ω_{ss} is the value of the motor's speed in steady state and V is the amplitude of the applied voltage to motor. From figure 6, placing the cursor 0 in steady state, we can read that $\omega_{ss} = 125,6$ rad/s. Taking into account that the amplitude of the applied voltage is 4,5 V (see figure 6), we have: $K_{ss} = 27,911$ rad/s.V.

Validation of the obtained result

Taking into account that $K_{ss} = 27,911$, $G_p = 63,438$.

In order to validate the determined value of G_p we configure (Setting the reference speed to 150 rad/s and $G_p = 63,438$) and run the service Closed loop with P Controller. The screenshot of the service interface is shown in figure 7.



Figure 7. Interface of the closed loop with P Controller service.

From Figure 7, placing the cursor 0 in steady state, we can read that $\omega_{ss} = 128,2$ rad/s.

The real steady state error obtained is:

$$e_{ss}^r = \frac{150 - 128,2}{150} 100 = 14,533\%$$

Note that the obtained real steady state error (14,533%) is nearly the desired steady state error (15%)

The proposed approach is also applied to Kirchhoff's Laws experiments for undergraduate students in electrical circuit course.

For this experiment the following services are available:

Service 1: Measurements of Voltages. With this service for a given circuit the interested nodes are shown on the circuit. In order to measure voltage across given nodes, the user has to:

- a) Select the appropriate nodes (number and polarity for each node);
- b) Select the amplitude of the voltage source to be applied to the circuit;
- c) Read the correspondent value on a numerical indicator.

Service 2: Measurements of currents. With this service, for the nodes where the circuit can be opened are shown. In order to measure a current flowing across a given branch the user has to:

- a) Select the amplitude of the voltage source to be applied to the circuit;
- b) Select the appropriate nodes (number and polarity for each node);
- c) Read the correspondent value on a numerical indicator.

Learning scenario and Lab Report (From the teacher)

Given the circuit shown in Figure 8:

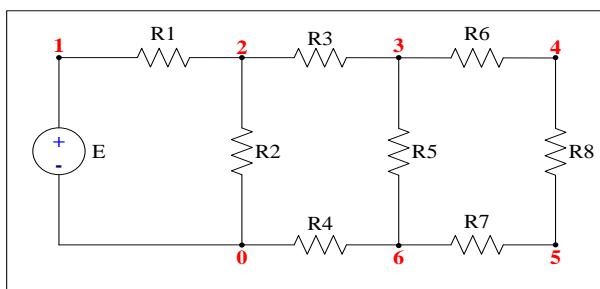

Figure 8. Analyzed circuit.

Use Kirchhoff's Laws Experiment to verify the Kirchhoff voltage law for the loop formed by resistors R2, R3, R4 and R5 given that the value of the amplitude the generator $E = 10$ Volts.

In your Lab report do the following:

- a) Select the appropriate service(s).

The interface of the appropriate service is shown below:

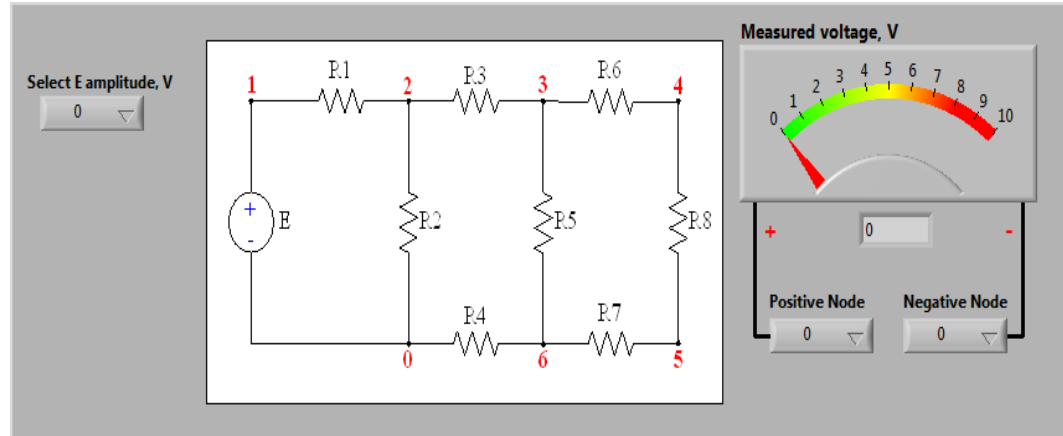

Figure 9. Interface of the Measurements of Voltages Service

- b) Write the Kirchhoff's voltage law and verify this law with the measured voltages.

Expected Lab Report to be filled by the student

- a) Selection of the service

Kirchhoff's voltage law is based on summing voltages around loops, so in this case the Service 1 is the appropriate service as it allows to measure voltages across all elements of the circuit.

- b) Applying Kirchhoff's voltage law (KVL)

The selected signs for the nodes are shown in the table below

Node	0	2	3	6
Sign	-	+	-	+

The measured voltages are shown in the table below

Voltages	U_{R2}	U_{R3}	U_{R4}	U_{R5}
Values, V	1,501	1,03	2,007	1,503

In the table above U_{Ri} is the voltage across the resistor R_i

In this the KVL equation clockwise around the loop using passive sign convention is:

$$U_{R3} - U_{R5} + U_{R4} - U_{R2} = 0 \quad (6)$$

Taking into account the measured values of the voltages, we obtain:

$$1,03 - 1,503 + 2,007 - 1,501 = 0,033.$$

Note that the obtained sum is close to zero.

Conclusion

With the proposed approach, the teacher can choose either to ask students to perform the predetermined steps of a given experiment or give them the opportunity to choose for themselves all the steps required in order to achieve the goals of the experiment. The latter approach is the best way to assess the student's learning process. Applying the approach we were able to find out if the learner truly understood the theoretical concepts learned in Control System course. Moreover, we found that expanding several services of each experiment allows more flexibility when many institutions remotely share the same devices. Furthermore, the teacher is then able to formulate the goals of an experiment according to the learning outcomes he/she expects.

In this paper the application of the proposed approach to experiment in Control systems course has been illustrated. We provide an example of how we are using the same approach for Electric circuit analysis. The approach can also be used in the context of some other courses. The usefulness of the proposed approach depends on the ability of the teacher to provide adequate set of services for each experiment and the detailed description of the functionality of each service. In a future work we will specifically address, in the framework of this approach, the issue of the collaborative use of a remote laboratory with not only one single service at a time but in cases where multiples services are needed to perform a laboratory learning task. We will also orient our effort toward the compliance of our approach with the ongoing IEEE-SA P1876™ Working Group achievements [17].

References

- [1] M. M. Dodo Amadou, M. Saad, J. P. Kenne, and V. Nerguizian, "Virtual and Remote Laboratories," in Proc. 1st IEEE ICELIE, Dec. 2006, pp. 173–176.
- [2] P. Permezel, O. Marcoux, H. H. Saliah, M. Saad and C. Nerguizian, "Generic Simulator Model for Training and Learning in Virtual Laboratory Environments," in E-Learn, World Conference on E-Learning in Corporate, Government, Healthcare and Higher Education, Montreal, Canada, October 15-19, 2002.
- [3] H. Kliffi, J. Desbiens, M. Cheriet, M. Saad and H. H. Saliah, "Building a Virtual Laboratory over a Duplicated Object Systems," in 2nd International Workshop on Tele-Education in engineering Using Virtual Laboratories, August 8-9, 2002, Sherbrooke, Canada.
- [4] K.M. Lee, W. Daley, and T. McKlin, "An interactive learning tool for dynamic systems and control," in Proc. Int. Mechanical Engineering Congr. Expo., Anaheim, CA, 1998, pp. 71–76.

- [5] C. Schmid, "The virtual lab VCLAB for education on the Web," in Proc. American Control Conf., Philadelphia, PA, 1998, pp. 1314–1318.
- [6] E. Sancristobal Ruiz et al., "Virtual and remote industrial laboratory: Integration in learning management systems," IEEE Ind. Electron. Mag., vol. 8, no. 4, pp. 45–58, Dec. 2014.
- [7] T. de Jong, M. C. Linn, and Z. C. Zacharia, "Physical and virtual laboratories in science and engineering education," Science, vol. 340, no. 6130, pp. 305–308, 2013.
- [8] Agel Valera, José Luis Diez, Marina Vallés and Pedro Albertos, "Virtual and Remote Control Laboratory Development," IEEE Control Systems Magazine, February 2005, vol. 25, no. 1, pp. 35-39.
- [9] M. Casini, D. Prattichizzo and A. Vicino, "The Automatic Control Telelab," IEEE Control Systems Magazine, June 2004, vol. 24, no. 3, pp.36-44.
- [10] M. M. Dodo Amadou, H. Saliyah Hassane and M. Saad, "Laboratories in Engineering Courses via Internet," in iCEER 2004 Conference, Ostrava, 2004.
- [11] W. E. Dixon, D. M. Dawson, B. T. Costic, and M. S. de Queiroz, "A MATLAB-based control systems laboratory experience for undergraduate students: Toward standardization and shared resources," IEEE Transactions on Education, vol. 45, no. 3, August 2002, pp.218-226.
- [12] C. C. Ko, Ben M. Chen, Jianping Chen, Yuan Zhuang, and Kay Chen Tan, "Development of a Web –Based Laboratory for Control Experiments on Coupled Tank Apparatus," IEEE Transactions on education, vol.44, no. 1, February 2001, pp.76-86.
- [13] H. H. Saliyah, M. Saad, L. Villardier, B. Assogba, C. Kedowide and T. Wong, "Resource Management Strategies for Remote Virtual Laboratory Experimentation," in Proceedings of the 2000 Frontier in Education Conference; Building on a Century of Progress in Engineering Education, Kansas City, October 18-21, 2000.
- [14] D. Gillet, T. de Jong, S. Sotirou, and C. Salzmann, "Personalised learning spaces and federated online labs for STEM education at school" in Proc. IEEE Global Eng. Edu. Conf. (EDUCON), Mar. 2013, pp. 769–773.
- [15] Remote Panels in LabVIEW -Distributed Application Development,
<http://www.ni.com/tutorial/4791/en/>
- [16] Norman S. Nise "Control Systems Engineerings", Seventh Edition, Wiley.
- [17] IEEE-SA P1876™ Standard for Networked Smart Learning Objects for Online Laboratories: http://standards.ieee.org/email/2012_09_cfp_P1876wg_web.html