

Highlighting and Examining the Importance of Authentic Industry Examples in a Workforce Development Certificate Program

Dr. Michael Johnson, Texas A&M University

Dr. Michael D. Johnson is an associate professor in the Department of Engineering Technology and Industrial Distribution at Texas A&M University. Prior to joining the faculty at Texas A&M, he was a senior product development engineer at the 3M Corporate Research Laboratory in St. Paul, Minnesota. He received his B.S. in mechanical engineering from Michigan State University and his S.M. and Ph.D. from the Massachusetts Institute of Technology. Dr. Johnson's research focuses on design tools; specifically, the cost modeling and analysis of product development and manufacturing systems; computer-aided design methodology; and engineering education.

Dr. Bimal P. Nepal, Texas A&M University

Dr. Bimal Nepal is an assistant professor in the Industrial Distribution Program at Texas A&M University. His research interests include integration of supply chain management with new product development decisions, distributor service portfolio optimization, pricing optimization, supply chain risk analysis, lean and six sigma, and large scale optimization. He has authored 30 refereed articles in leading supply chain and operations management journals, and 35 peer reviewed conference proceedings articles in these areas. He has B.S. in ME, and both M.S. and Ph.D. in IE. He is a member of ASEE, INFORMS, and a senior member of IIE.

Dr. Norma Perez, Houston Community College

Dr. Perez is currently the Associate Vice Chancellor of Curriculum and Learning Initiatives at Houston Community College (HCC). She has served in various positions during her thirty years of service to HCC, such as Executive Dean, Dean of Health Sciences, and Director of Institutional Assessments. Dr. Perez was instrumental in working with faculty to create the first student success course for the Health Sciences students to impact the success rate of these students. Dr. Perez also worked with faculty and industry experts to create several new programs, such as Histologic Technician, Computed Tomography, Cardiovascular Technology, Massage Therapy, and Dental Hygiene. In 2015, she worked with faculty and industry experts to create the Insurance Associate/Specialist program to train students for the insurance business. Most recently, Dr. Perez worked with the HCC Manufacturing Center of Excellence and Texas A & M University in the development of a new certificate, High Value Manufacturing, made possible through an NSF Grant initiative. This initiative also involved the manufacturing industry representatives to ensure that the certificate curriculum would meet the needs of the industry.

Highlighting and Examining the Importance of Authentic Industry Examples in a Workforce Development Certificate Program

Abstract

The importance of authenticity has been examined in various aspects of education; this is especially true in the area of engineering education where most graduates will matriculate to industry. However, the importance of applied and authentic examples could be even more critical in workforce development programs. In these cases, students are often enrolled with a goal of using their acquired knowledge to advance their career or move into a new role. Purely theoretical or stylized examples would not be aligned with the educational goals of these students.

As part of a National Science Foundation Advanced Technological Education grant, a certificate program in high value manufacturing (HVM) has been developed. The certificate program is a collaboration between a research intensive four-year institution and an urban community college. In this certificate program students will be taking courses in manufacturing processes, design, and other business-related subjects that are pertinent to the manufacture of low volume components that have high materials costs, stringent quality requirements, and critical project timelines. This unique content area requires example that comprise these pertinent aspects of HVM. This is particularly true of the five newly developed courses covering materials, project management, quality, logistics, and computer-aided design. While the analogous courses at a four-year degree granting institution would likely use stylized examples in these courses, this would not be preferable in an applied certificate program.

This work discusses the acquisition and refinement of authentic and applied examples that are applicable to the HVM environment. Specifically, the use of industry contacts and the translation of examples into useable and appropriate examples are examined. These examples are detailed and compared to traditional stylized academic content. A methodology for examining student perceptions of these examples is also proposed. A discussion of the importance of authenticity in applied certificate programs is also presented.

Introduction

Preparing the workforce of the future requires that potential employees have the technical knowledge necessary, but also professional skills and the ability to seek out future knowledge and skills as “lifelong learners”¹. Several methods for providing these skills have been proposed in higher education literature in general and engineering education literature in particular²⁻⁴. One aspect that has not received as much attention in these regards is technician-level training. Often, people who enroll in technical or certificate programs are looking to update or upgrade particular skills with the goal of getting a job in a particular industry or a promotion and raise at their current employer. In such cases, the relevancy and applicability of the curriculum becomes paramount. This work discusses the infusion of relevant examples into a curriculum developed as part of National Science Foundation Advanced Technological Education (ATE) grant.

Project-based and problem-based learning have both been widely promoted and used in engineering education. Problem-based learning focuses on contextual problems that are realistic⁵. There have been significant benefits associated with problem-based learning. Problem-based learning has also been associated with increased self-efficacy⁵. Self-efficacy is the belief one has

in their ability to accomplish tasks in specific situations. Self-efficacy is associated with greater effort and persistence⁶. These are important qualities to promote in a certificate program where non-traditional students might be trying to change or enhance their career opportunities. Problem-based learning is also associated with improved adaptive expertise⁷. Wineburg defines adaptive expertise as: “the ability to apply, adapt, and otherwise stretch knowledge so that it addresses new situations - often situations in which key knowledge is lacking”⁸. Adaptive expertise is differentiated from routine expertise by the combination of both innovation and efficiency (routine experts are merely efficient)⁹. Given changing technical needs, the promotion of adaptive expertise is also extremely beneficial. Problem-based learning is also associated with improved critical thinking and enthusiasm¹⁰.

de-Juan *et al.*¹¹ note that while problem based learning is more about generating knowledge, project-based learning is concerned with bring that knowledge to bear on a project that is ill-defined. Project-based learning has also been associated with improved self-efficacy¹². Project-based learning, when introduced into a mechanics course, improved course outcomes and exam scores¹³. The motivating aspects of project-based learning have also been highlighted¹⁴. Both problem-based and project-based learning are beneficial in the context of technician-level education programs.

One of the oft-cited aspects of project and problem-based learning is the applicability of the problem or project. Namely, there is a desire that the problems or projects that students are asked to work on be authentic in nature. Authentic problems are defined as those whose “primary purpose and source should be a need, a practice, a task, a quest and a thirst existing in a context outside of schooling and educational purposes”¹⁵. One of the early places that authenticity was promoted was in science education^{16,17}. Given that the ATE program is the “pinnacle of collaboration between industry and education”¹⁸, the incorporation of industry relevant examples is critical. Students that technology courses tend to be attuned to the ability of the content to prepare them for industry¹⁹. The importance of creating “real world” situations and activities is often noted^{20,21}. This authenticity is associated with students caring about what they learn²² and students becoming lifelong learners²¹.

As part of the curriculum development for this ATE project, industry examples were sought to inject authenticity into the curriculum. This work summarizes the certificate program that is being developed. Next, the proposed industry examples will be compared to traditional academic and stylized problems and activities. Next a method for assessing the impact of these alternative examples will be discussed. Finally, next steps and future work will be detailed.

High Value Manufacturing Certificate

The exercises and problems proposed in this work are for a certificate program that is being developed as part of a National Science Foundation (NSF) Advanced Technological Education (ATE) project. This project is a collaboration between Texas A&M University (TAMU) and Houston Community College (HCC). This project is developing a certificate program in High Value Manufacturing aimed at the oil and gas industry. High Value manufacturing is where components use high cost raw materials and have significant value added through processing; these components are manufactured in low volume and typically have values in the tens of thousands of dollars. These components also have demanding timelines for delivery and tight tolerances and quality standards. The certificate program being developed is aimed at providing technician-level personnel the skills necessary to operate in this unique area of manufacturing.

This requires the development of skills related to manufacturing and fabrication, but also the ability to put the manufactured component into the context of the overall customer need and firm operations. In addition to providing skills for the workforce, the certificate program aims to be stackable, so that participants can also matriculate to a four-year degree or beyond if they choose not to enter industry directly from the program. Figure 1 shows the potential inflows and pathways for certificate program participants. Figure 2 shows how the certificate program fits into the overall context of a degree program; in this case ending with a B.S. in Manufacturing and Mechanical Engineering Technology.

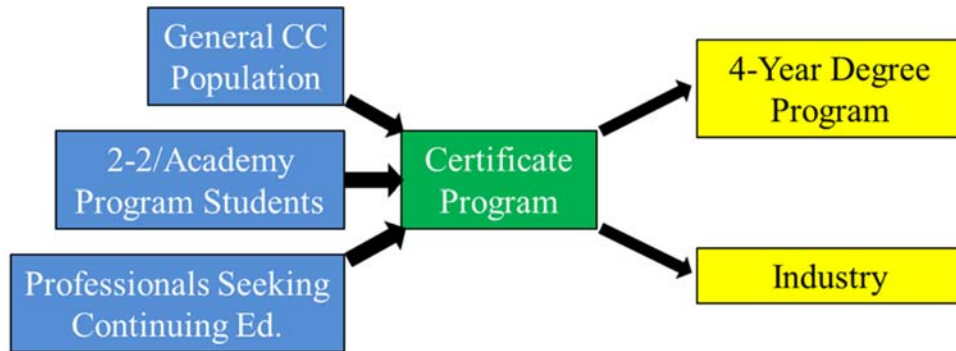

Figure 1: Certificate Program Pathways

Given the unique aspects of high value manufacturing, the certificate program was designed to provide the context of oil and gas exploration along with manufacturing. Specific courses were added to existing HCC offerings in these areas to highlight topics that are relevant to high value manufacturing. These courses included: materials, CAD and GD&T, quality, project management, and logistics in the context of a machine or job shop. The proposed certificate is what is known as a Level 2 certificate. It is an intermediate qualification comprising 52 credit hours, but not an academic A.A.S. degree (which requires 60). The courses will be offered in a combination of in person and distance learning. The curriculum is shown in Table 1; new courses are bolded.

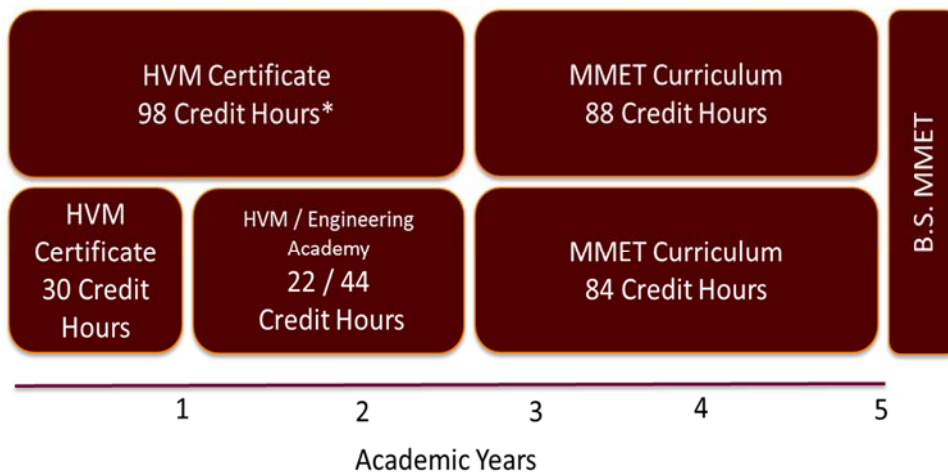

Figure 2: Academic Pathway to B.S.

Table 1. Proposed HVM Curriculum

Course Number	Course Number	Credit Hours
Semester 1		
ENTC 1347	Safety and Ergonomics	3
MATH 1314	College Algebra	3
MCHN 1302	Print Reading for Machining	3
MCHN 1338	Basic Machine Shop I	3
PTRT 1301	Introduction to Petroleum Industry	3
Semester 2		
MCHN 1308	Basic Lathe	3
MCHN 1313	Basic Milling Operations	3
INMT 1345	Computer Numerical Controls	3
INMT 1371	Materials and Applications	3
PTRT 1470	Petroleum Data Management I – Exploration	4
INCR 1302	Physics of Instrumentation	3
Semester 3		
PTRT 2370	Petroleum Operations	3
INMT 1343	Computer Aided Design/ Manufacturing (CAD/CAM)	3
INMT 1372	Quality and Assessment	3
INMT 2370	Project Management	3
INMT 1373	Machine Shop Logistics	3

The new courses are meant to provide additional context to the traditional manufacturing curriculum that similarly offered certificate programs would provide. This is in addition to the oil and gas exploration courses that provide an overall context to the types of equipment that is being produced and uses for said equipment. In the case of the *Materials and Applications* course, students will learn about basic applied materials science, but also be introduced to exotic materials as well as the material modifications that are likely to be applied to components used in oil and gas exploration (e.g., heat treatments). This course will also have a laboratory component associated with it to allow students to gain hands-on experience testing materials to evaluate their properties and better understand the relationship between these properties and their usefulness in various applications. The *Computer-Aided Design and Computer-Aided Manufacturing (CAD/CAM)* course will give students an understanding of CAD and CAM tools, but also introduce them to geometric dimensioning and tolerancing (GD&T). GD&T are critical to high value manufacturing components. Giving certificate program participants the ability to understand the relationship between the design (as shown in CAD), the manufacturing process (as detailed in the CAM program), and the necessary requirements (from the associated GD&T) will be very beneficial. Again, given the quality requirements associated with high value manufacturing, a course in *Quality and Assessment* will provide participants with the understanding of basic statistics associated with quality along with how to assess alternative product attributes. To understand the role of the manufacturing process of particular components in overall production effort and to provide overall context of the oil and gas exploration enterprise, a *Project Management* course is also included. In this course, students will learn how

to control project timelines, monitor budgets, and assess the implications of project changes. The final additional course is *Machine Shop Logistics*; in this course, students will be provided insights into how materials move through a job shop. This will also introduce them to scheduling, inventory management, and the cost implications of alternative decisions. Overall, the high value manufacturing certificate curriculum is aimed at providing technician-level staff the ability to better function and provide value in a competitive and demanding industry.

Industry Case Studies

To better provide students with the skills necessary to function in a high value manufacturing environment and to promote student interest²² and lifelong learning²¹, authentic industry examples were sought from partners and contacts of the project team. While numerous cases and example problems were collected (and are still being collected) representative examples for three of the courses are presented. They are compared with stylized or general book examples that would typically be used in similar courses. A discussion of how these problems and cases highlight important aspects of high value manufacturing is also included.

Computer-Aided Design

One area where stylized examples are often used is in computer-aided design. Contextual CAD exercises, or those having some meaning to the student, have been shown to have a positive effect on adaptive expertise²³. The model of a connection component that could be used for various aspects of the high value manufacturing curriculum is shown in Figure 3. This component is threaded and has an intermediate design complexity. In addition to its potential use in the CAD modeling instruction, this component can also be used for CAM process planning. The dimensions and quality associated with various features can also be used to detail GD&T aspects. Given the component's authenticity, students can better understand why certain manufacturing aspects of the model are important. This is in comparison to a stylized textbook²⁴ component shown in Figure 4. This component has similar complexity, but obviously does not serve a significant purpose (other than CAD instruction).

Figure 3. Authentic Connection Component

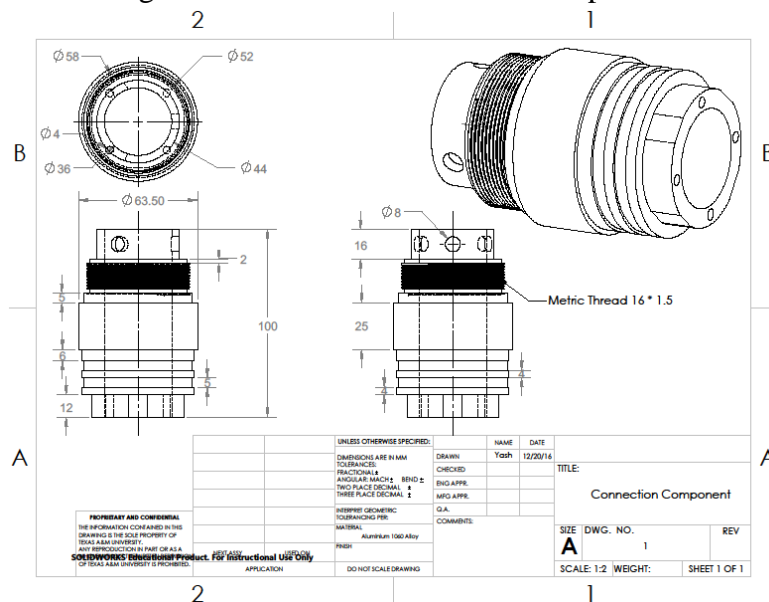
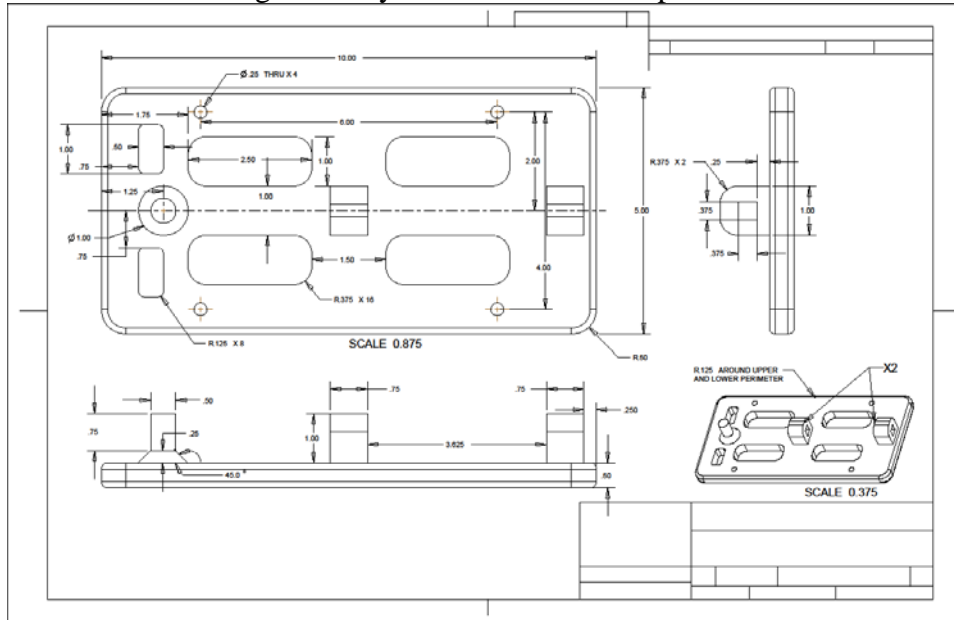

Figure 4. Stylized Textbook Component



Project Management

Understanding the critical timelines associated with the high value components used for oil and gas exploration is necessary to provide context for the technical personnel working on these components. While project management tools can be taught using stylized examples, authentic examples would provide the students with additional motivation and allow them to better understand high value manufacturing. An example of a large production project was shared with the project team. It has been condensed, but shows the steps necessary to create a set of components used in a deepwater oil drilling platform. This is compared to textbook example²⁵. While they have the same number of steps, the authentic example will allow students to better understand the steps that go into creating high value componentry for oil and gas exploration. It also includes the cost of necessary contingencies required to meet deadlines. These two cases are shown in Table 2.

Table 2. Alternative Project Management Examples

	Textbook Case	Authentic Case
1	Problem Definition	Procure ingots for given metallurgy
2	System Analysis	Develop weld procedure
3	Design Input & Output	Extrude 30' lengths
4	Design Database	Pull bore and hone ID for tubing
5	Develop Input Screen	Turn OD and shape tapered stress joint
6	Develop Output Screen	Weld 150' lengths
7	Develop Database	Inspect
8	Test System	Shipping with contingency plan (Houston to Europe)
9	Implement System	Assemble on site

Machine Shop Logistics

Understanding the effects of operations in a job shop or a machine shop on the overall cost of the product is critical in high value manufacturing. Unnecessary and nonvalue-added operations can

cause quality problems and effect overall timelines. To highlight an analysis of these operations a case was secured that detailed how to remove costs from an oilfield tool called a packer; this is a tool that seals off a certain section of the well. The analysis of this tool required the identification of the various steps associated with producing the packer, their costs, and developing potential cost reduction solutions. These are shown in Figure 5.

Figure 5. Cost Reduction Ideas

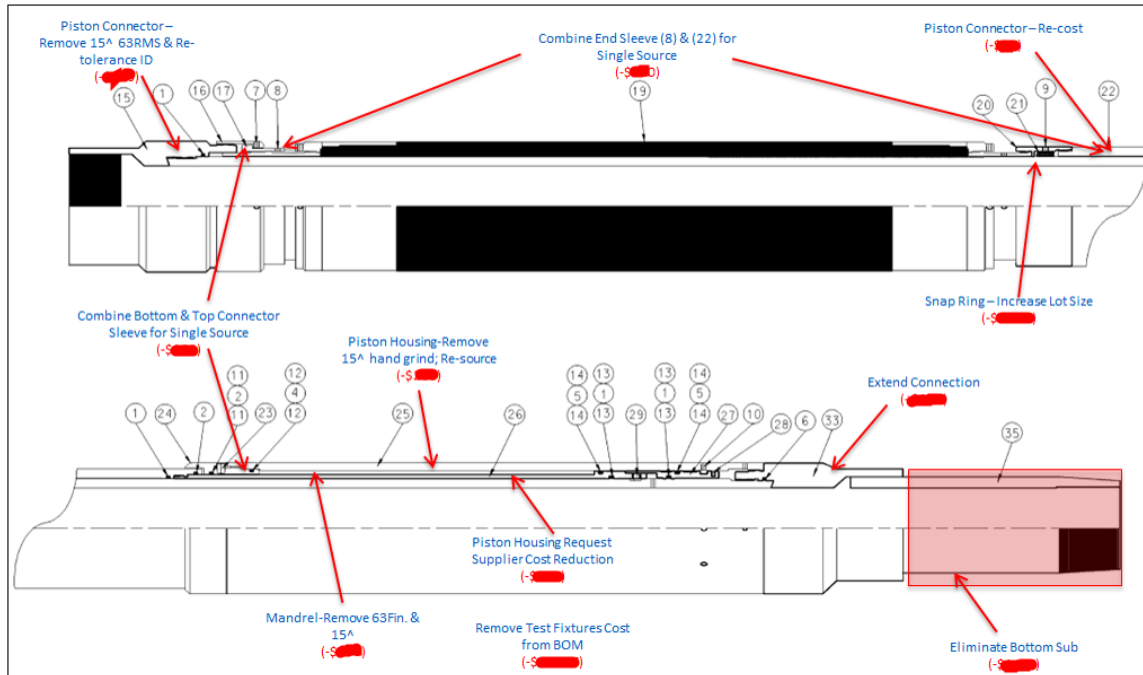

Table 3 provides a comparison of topics that can be found in a typical textbook on production, planning, and control or a quality management text when discussing about the cost reduction process in an industry and an authentic example as shown in Figure 5. As shown in Table 3, the textbook discussions are very generic and are mostly focused on broad conceptual discussions. For example, the main case study used to describe the concept of just-in-time and lean production in Heizer and Render²⁶, one of the highly adopted textbook in production, planning, and control, is not even from manufacturing. While textbook cases provide a greater variety of examples, for certificate students, whose focus is to get ready on the first day at the job, such concept will not achieve that objective. For these students, having authentic examples that can directly relate to their work environment (such as Figure 5) can be much more impactful.

Assessment

As mentioned previously, it is critical for certificate program participants to understand the context of the content they are learning and feel that it is valuable to them. To assess this value, the instrument developed by Mativo *et al.*¹⁹ will be used across the various certificate program courses. This instrument is a 20 question survey that uses a Likert scale²⁷ based on the agreement of such questions as “This course was a waste of time” or “The information presented in this course is out of touch with the ‘real world’”. The original instrument was aimed at high school engineering and engineering technology courses, so it will need to be slightly altered for the purposes of this work.

Table 3: Examples of Textbook case and authentic industry example in production and quality management

	Textbook Case	Authentic Case
1	Problem Definition	List the steps involved and their current sequence of operations for producing packer tool
2	Data Collection	Time each activity involved in producing the packer tool
3	Data analysis	Identify bottle neck activity, evaluate tolerance requirement for more complex operations like piston connector and piston housing
4	Root cause analysis	Collaborative discussion among design, manufacturing, and suppliers potential design simplification to make the assembly more efficient and reliable
5	To be process	Remove 15 ⁶³ RMS & Re-tolerance ID, remove test fixtures
6	Control and continuous improvement	Request supplier cost reduction

In addition to assessing certificate program participants, the instrument will also be distributed in some analogous courses at the four-year institution to see if the commonly used textbook examples produce any different responses. This will allow a comparison of the applicability of the examples used in the two alternative settings. Given the more applied nature of a certificate program, it would be assumed that the students would rate the applicability of their courses higher than those of the four year institution.

Conclusions

The importance of authenticity in engineering education has drawn wide interest in the academic community. More importantly, the workforce development programs whose focus is to produce graduates who are ready to contribute immediately in industry, or to provide professional development opportunities for returning employees, value of authentic examples would become even more critical than in the traditional four-year degree programs. Purely conceptual or stylized examples would not be aligned with the educational goals of the students in the workforce development programs. This paper has presented how authentic and applied examples that were applied to a high value manufacturing certificate program targeted to energy industry. The HVM certificate was developed as a part of an ATE grant. As a part of grant, the project is currently developing five new courses in materials, project management, quality, logistics, and computer-aided design. The paper provided sample examples of both stylized and authentic examples and discussed the pros and cons of both pedagogical approaches. Lastly, the paper also discussed how student perceptions of those examples could be assessed and analyzed for continuous improvement.

Acknowledgement

This material is supported by the National Science Foundation under DUE Grant Numbers 1501952 and 1501938. Any opinions, findings, conclusions, or recommendations presented are those of the authors and do not necessarily reflect the views of the National Science Foundation.

References

- [1] Wang, J., Fang, A. & Johnson, M., (2008). Enhancing and assessing life long learning skills through capstone projects. *ASEE Annual Conference and Exposition, Conference Proceedings*. Pittsburgh, PA, 2008-324.
- [2] Shuman, L.J., Besterfield-Sacre, M. & MCGourty, J., (2005). The abet "professional skills" — can they be taught? Can they be assessed? *Journal of Engineering Education*, 94 (1), 41-55.
- [3] Earnest, J., (2005). Abet engineering technology criteria and competency based engineering education. *35th ASEE/IEEE Frontiers in Education Conference*. Indianapolis, IN, F2D-7-F2D-12.
- [4] Johnson, M.D. & Wang, J., (2015). A method for assessing required course-related skills and prerequisite structure. *European Journal of Engineering Education*, 40 (3), 297-308.
- [5] Dunlap, J.C., (2005). Problem-based learning and self-efficacy: How a capstone course prepares students for a profession. *Educational Technology Research and Development*, 53 (1), 65-83.
- [6] Pajares, F., (1996). Self-efficacy beliefs in academic settings. *Review of educational research*, 66 (4), 543-578.
- [7] Froyd, J.E., (2011). Problem-based learning and adaptive expertise. *Proceedings - Frontiers in Education Conference, FIE*. Rapid City, SD, SB3-1-SB3-5.
- [8] Wineburg, S., (1998). Reading abraham lincoln: An expert/expert study in the interpretation of historical texts. *Cognitive Science*, 22 (3), 319-346.
- [9] Schwartz, D.L., Bransford, J.D. & Sears, D., (2005). Efficiency and innovation in transfer. In Mestre, J.P. ed. *Transfer of learning from a modern multidisciplinary perspective*. Greenwich, CT :: IAP.
- [10] Golter, P., Van Wie, B. & Brown, G., (Year). Comparing student experiences and growth in a cooperative, hands-on, active, problem-based learning environment to an active, problem-based environment. eds. *ASEE Annual Conference and Exposition, Conference Proceedings*, Honolulu, Hawaii: ASEE, 2007-2972.
- [11] De-Juan, A., Fernandez Del Rincon, A., Iglesias, M., Garcia, P., Diez-Ibarbia, A. & Viadero, F., (2016). Enhancement of mechanical engineering degree through student design competition as added value. Considerations and viability. *Journal of Engineering Design*, 27 (8), 568-589.
- [12] Seth, D., Tangorra, J. & Ibrahim, A., (Year). Measuring undergraduate students' self-efficacy in engineering design in a project-based design course. eds. *Frontiers in Education Conference (FIE), 2015. 32614 2015. IEEE*, 1375-1382.
- [13] Hadim, H.A. & Esche, S.K., (Year). Enhancing the engineering curriculum through project-based learning. eds. *Frontiers in Education, 2002. FIE 2002. 32nd Annual*, F3F-1-F3F-6 vol.2.
- [14] Welch, R.W. & Estes, A.C., (Year). Project-based independent study capstone course. eds. *Proceedings of the Structures Congress and Exposition*, 1281-1292.
- [15] Strobel, J., Wang, J., Weber, N.R. & Dyehouse, M., (2013). The role of authenticity in design-based learning environments: The case of engineering education. *Computers & Education*, 64 (0), 143-152.
- [16] Edelson, D.C., (1998). Realising authentic science learning through the adaptation of scientific practice. In Fraser, B. & Tobin, K. eds. *International handbook of science education*. Springer, 317-332.

- [17] Schwartz, R.S., Lederman, N.G. & Crawford, B.A., (2004). Developing views of nature of science in an authentic context: An explicit approach to bridging the gap between nature of science and scientific inquiry. *Science Education*, 88 (4), 610-645.
- [18] Zinser, R. & Lawrenz, F., (2004). New roles to meet industry needs: A look at the advanced technological education program. *Journal of Vocational Education Research*, 29 (2), 85-99.
- [19] Mativo, J.M., Womble, M.N. & Jones, K.H., (2013). Engineering and technology students' perceptions of courses. *International Journal of Technology and Design Education*, 23 (1), 103-115.
- [20] Park, K. & Park, S., (2012). Development of professional engineers' authentic contexts in blended learning environments. *British Journal of Educational Technology*, 43 (1), E14-E18.
- [21] Snape, P. & Fox-Turnbull, W., (2013). Perspectives of authenticity: Implementation in technology education. *International Journal of Technology and Design Education*, 23 (1), 51-68.
- [22] Kreber, C., Klampfleitner, M., Mccune, V., Bayne, S. & Knottenbelt, M., (2007). What do you mean by "authentic"? A comparative review of the literature on conceptions of authenticity in teaching. *Adult Education Quarterly*, 58 (1), 22-43.
- [23] Johnson, M.D., Ozturk, E., Valverde, L., Yalvac, B. & Peng, X., (2013). Examining the role of contextual exercises and adaptive expertise on cad model creation procedures. In Kurosu, M. ed. *Human-Computer Interaction Part II*. Berlin: Springer-Verlag, 408-417.
- [24] Toogood, R. & Zecher, Z., (2011). *Creo parametric 1.0 tutorial and multimedia cd* Mission, KS: SDC Publications.
- [25] Gido, J. & Clements, J., (2015). *Successful project management* Stamford, CT: Cengage Learning.
- [26] Heizer, J. & Render, B., (2006). *Operations management*, 8th ed. Upper Saddle, NJ: Pearson.
- [27] Likert, R., Roslow, S. & Murphy, G., (1934). A simple and reliable method of scoring the thurstone attitude scales. *Journal of Social Psychology*, 5, 228-238-238.