

## Cellular Automatic Temperature System (CATS) for Vehicles

Michael Bell, Laura Gonzalez, Bao Quach, Steven Shakarisaz, Farrokh Attarzadeh,  
Mayuri Mahajan  
Engineering Technology Department  
University of Houston

### Abstract

This paper describes the results of a research project completed in Spring 2008 at the University of Houston and shows details of the subsystems along with future enhancements of the Cellular Automatic Temperature System (CATS) for Vehicles. The interior of a vehicle can reach an extremely uncomfortable temperature after being left in the sun especially in the southern region of the United States. At such times, when a driver returns to his or her vehicle, they must sometimes cool it off themselves by venting the hot air; otherwise the interior components like the steering wheel or leather seats will be too hot to touch and could be distracting leading to lose control of the car. CATS was designed to provide an automatic system which helps in cooling the car. The driver is able to program the CATS by setting a desired cooling time before entering the vehicle. CATS is controlled using a cell phone or a web enabled system. Where CATS differs from other remote starter systems is the ability to start the car from anywhere by using a cellular telephone (or land line) or a web-based interface. The pager will turn the system ON depending on the car's temperature. The interfacing of the pager with the system is explained in the following sections. The system when turned ON sets the ignition to ON position and starts the air condition to decrease the temperature in the car. It hence, proves to be quite helpful and efficient in many ways. The CATS was implemented in a 1995 Ford Escort and its functionality tested successfully. The Cellular Automatic Temperature System for Vehicles is currently under review by the office of Intellectual Property Management at the University of Houston for a potential patent.

### Introduction

This paper presents the design specification of a Cellular Automatic Temperature System (CATS) for vehicles. The system is designed to create a comfortable environment inside of an automobile before the driver enters the car. CATS is an electronic device installed in the user's car which can be controlled from any telephone, including cellular telephones, or a web-enabled computer. In summer months, especially in the southern region of the United States, the interior of a vehicle can reach an extremely uncomfortable temperature after being left in the sun. According to a recent studies, it is not uncommon to find the temperature inside the vehicle's passenger compartment above 120° Fahrenheit [1]. While the target market for the CATS is the United States, if costs are kept down this device has the potential to take the lead both domestically and abroad in developing, rapidly-expanding markets such as India and China.

The prototype of the CATS, shown in Figure 1, is a remote starter for an automobile combined with an environmental control system.



Figure 1. Prototype of the CATS during test

The project design is a cost effective option as a pager is interfaced with the microcontroller which can be controlled by the cell phone or through the web. A temperature sensor in the CATS is monitored and a decision is made whether or not the air conditioner has to be turned ON. The microcontroller also receives an input from the key switch. In case the driver starts the car using a key, the CATS is disabled. The microcontroller is interfaced with the window mechanism and the air conditioner unit and facilitates the hot air to be escaped form the interior of the vehicle.

## System Overview

CATS is a compact vehicle cooling system which is controlled automatically.

The CATS is comprised of several subsystems as shown in Figure 2. The Pager, Temperature Sensor, and vehicle cooling start up system. The entire system is controlled by an 8051 microcontroller and its associated components.

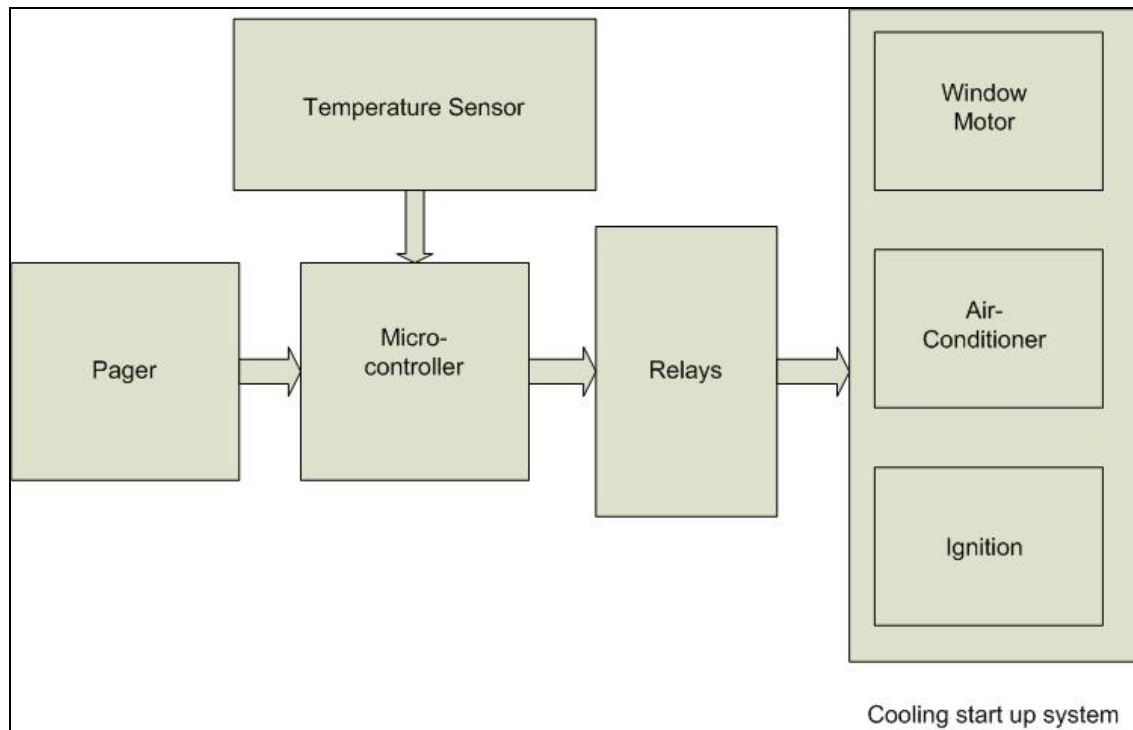

Figure 2. Subsystems of the Cellular Automatic Temperature System

The function of the pager is to receive messages from the user and send a pulse to the microcontroller and a signal to the system to start depending on the temperature detected in the vehicle by the temperature sensor. The microcontroller is interfaced with the window's motor, air conditioner unit and the ignition system and is explained later.

## Design Specifications

The design uses the MINI-MAX 8051 microcontroller, the ST-800 Plus Model 1 pager from Sun Telecom, LM 34 temperature sensor, the 12V car's battery, 74LS04 TTL logic inverter, Hex buffers and relays. The hardware layout of the system is shown in Figure 3.

The key benefits of this system are listed below.

- Remote car starter with virtually limitless range
- Activate the system using *any* telephone or web-enabled computer
- Gas and battery power will be saved by using the CATS cooling system.
- A cool car when you enter the car!

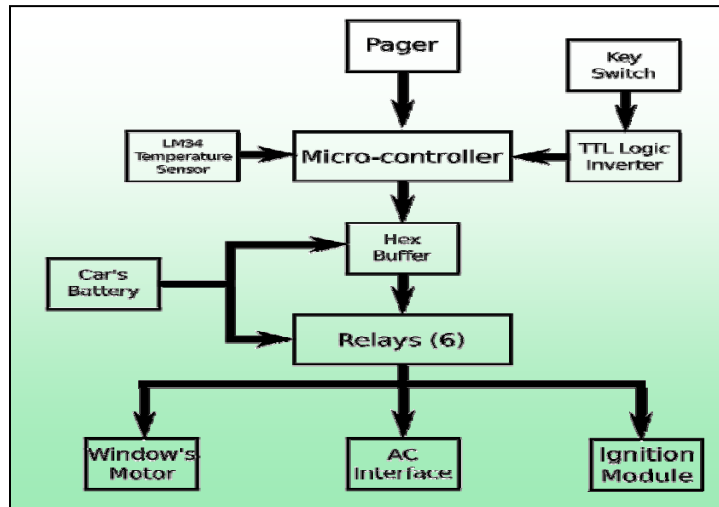

Figure 3. Hardware block diagram

### Microcontroller

The BiPOM MINI-MAX/51-C2 [2] is used in this system. The two external interrupt ports of the microcontroller are utilized to send signals from the pager and the key switch. This is the main module of the CATS. The microcontroller receives all inputs and controls the car's system via an array of relays.

### Pager

A ST-800 Plus model 1-way numeric pager from Sun Telecom [3] with services from SkyTel Communications is used. The ST-800 Plus is the most basic pager with ability to display the received numeric messages. Its main role in CATS is to receive a message and interrupt the microcontroller. The interface with the microcontroller is a wire soldered to one terminal of the speaker. Figure 4 shows the Pager connection.

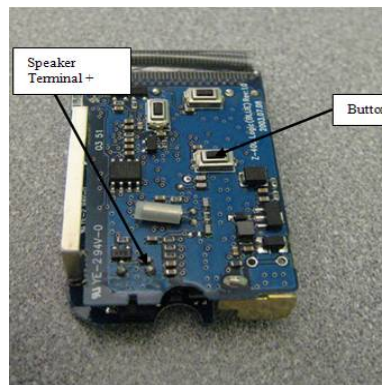

Figure 4. Pager Connection

### TTL Logic Inverter

74LS04 is used as a TTL logic inverter in this system. This is used to invert the signal from the key switch and send it to the microcontroller. When the key is inserted to turn on the ignition and is turned to the "run" position, a 12-volt signal is sent through one of the wires in the wiring harness. Since the 8051's interrupts are active low, a logic inverter

is used to produce a low-level signal when the key is inserted, triggering the second external interrupt.

### Temperature Sensor

LM 34 temperature sensor is used to measure the temperature inside the car. It provides the reading in degrees Fahrenheit.

### Car Battery

A voltage of 12V is taken from the car's battery to power the relays, which in turn will provide power to the car's system. Voltage is not taken directly from the battery itself, but rather from two "always hot" wires that provide voltage to the steering column circuitry of the car.

### Hex Buffers

Hex buffers are used to protect and control the high current relays. The microcontroller will send a TTL logic signal into the hex buffer input. If it is low, then the hex buffer will provide a ground path to the relay's coil and turn on that relay. Otherwise the hex buffer's output will be floating and the relay will be off.

### Relays

Relays are used since many components inside the car need to be switched mechanically. The CATS used 6 relays that can handle 120 volts and 40 amperes. These provide enough power to operate the three car subsystems namely the window's motor, the A/C and the ignition. The output of each relay is connected to the switches of the car's components. Figure 5 shows the 5 pin relays used in the design.

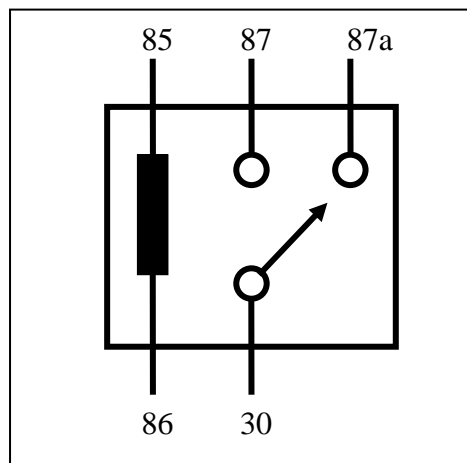

Figure 5. 5 pin Relays

The array of relays in the CATS enclosure is shown in Figure 6.

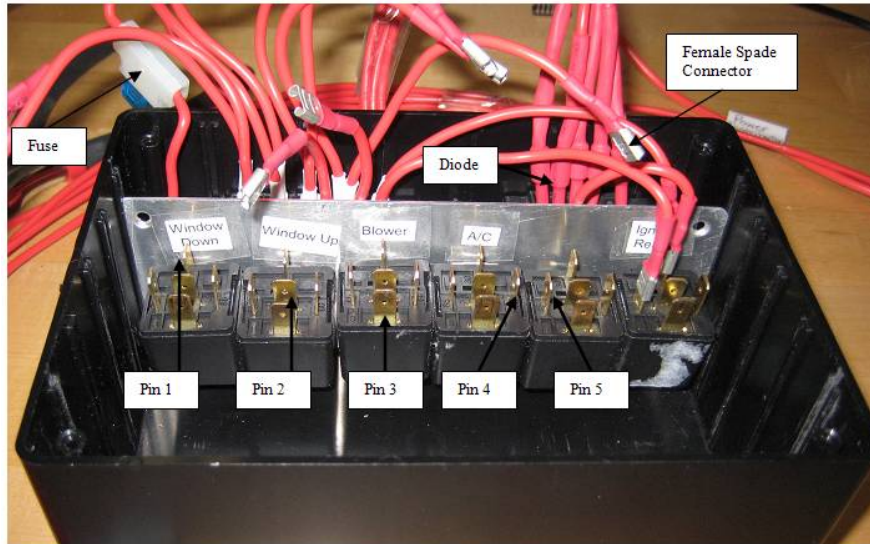

Figure 6. Array of relays and their assignments

### Hardware Description

The temperature sensor is connected to the microcontroller input. The pager speaker connection and key detection are connected to the microcontroller interrupts. When a page is received, a pulse is sent to the microcontroller to indicate the start of the system. If the key is present, the program will prevent the software program from being executed by mistake while the user is driving until the ignition is turned off. Output pins are assigned to the hex buffer. A hex buffer is used to provide ground (GND) to a pin on the relay.

### Window Control Mechanism

Window control is provided by a set of two relays. A DC motor installed in the door controls the up and down movements of the windows. Wires on the door-mounted wiring harness are attached that contains the window switch. Voltage on one wire controls the upward movement while voltage on the second wire controls the downward movement. When voltage is sent to one wire, a ground path must be provided on the opposite wire. Figure 7 shows the Window motor's operation.

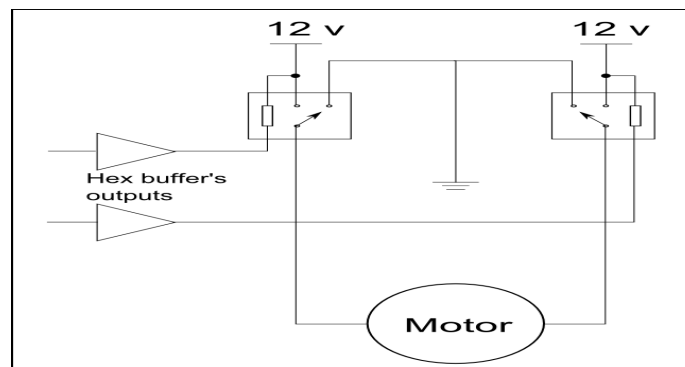

Figure 7. Window Motor's operation

## A/C interfacing

Control of the air conditioner system is provided by two relays. A parallel connection to the existing wires has been made for two key functions of the A/C: blower motor and the switch between cooling and blower only. Voltage is not sent to these wires; a short is created in both cases. Shorting two connections on the bottom of the relay starts the blower motor, while shorting two connections on the speed switch sets the speed to maximum. Figure 8 shows the window and A/C control circuitry.

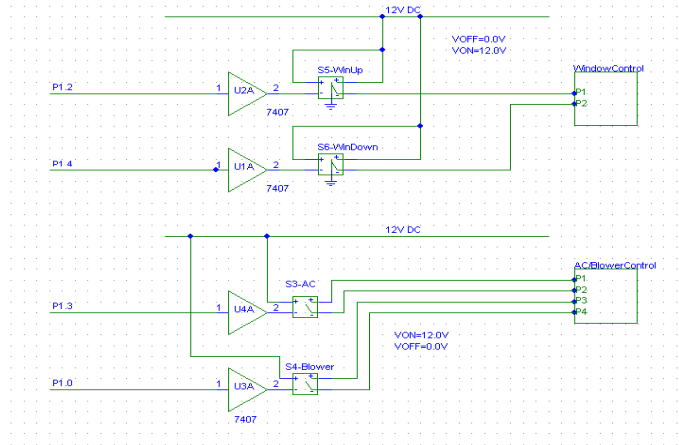

Figure 8. Window and A/C Control

## Starter System

A wiring harness is used to control the starter system. Figure 9 shows the wiring harness and the CATS box is connected to the existing car wiring. Two sets of diodes are used on these wires. The first set, close to the steering column, controls the flow of current coming from the CATS box, preventing damage to the steering column wiring. A second set of diodes is used to direct the current away from the CATS box when a user starts the car using an ignition switch. Figure 10 shows the starter system circuitry.

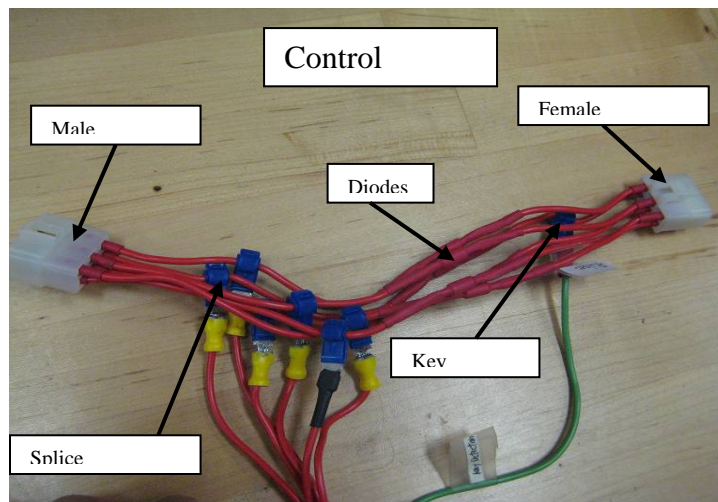

Figure 9. Wiring Harness

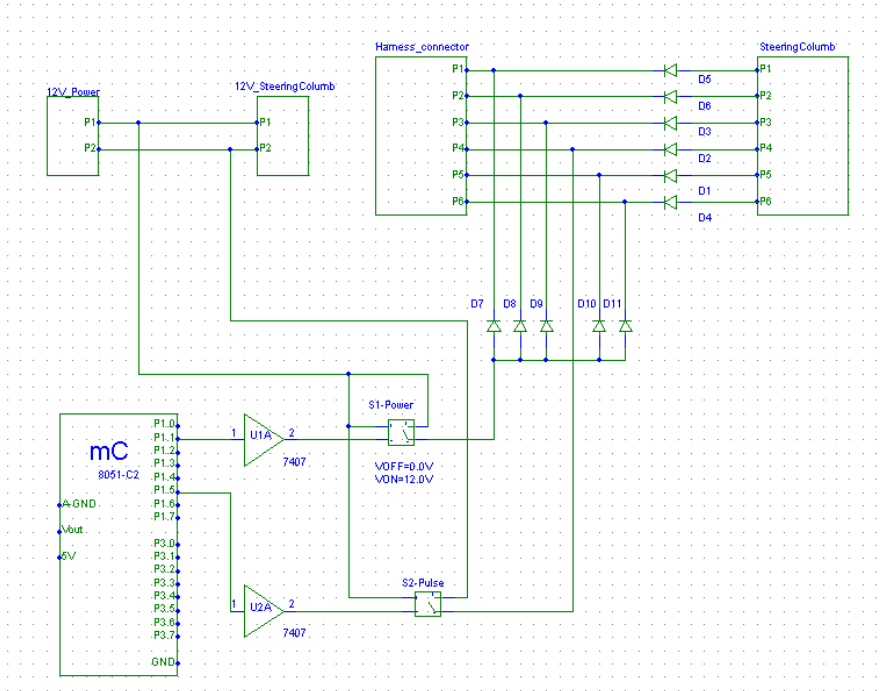

Figure 10. Starter system circuitry

### Software Description

The Figure 11 shows the basic flowchart of the software that was implemented.

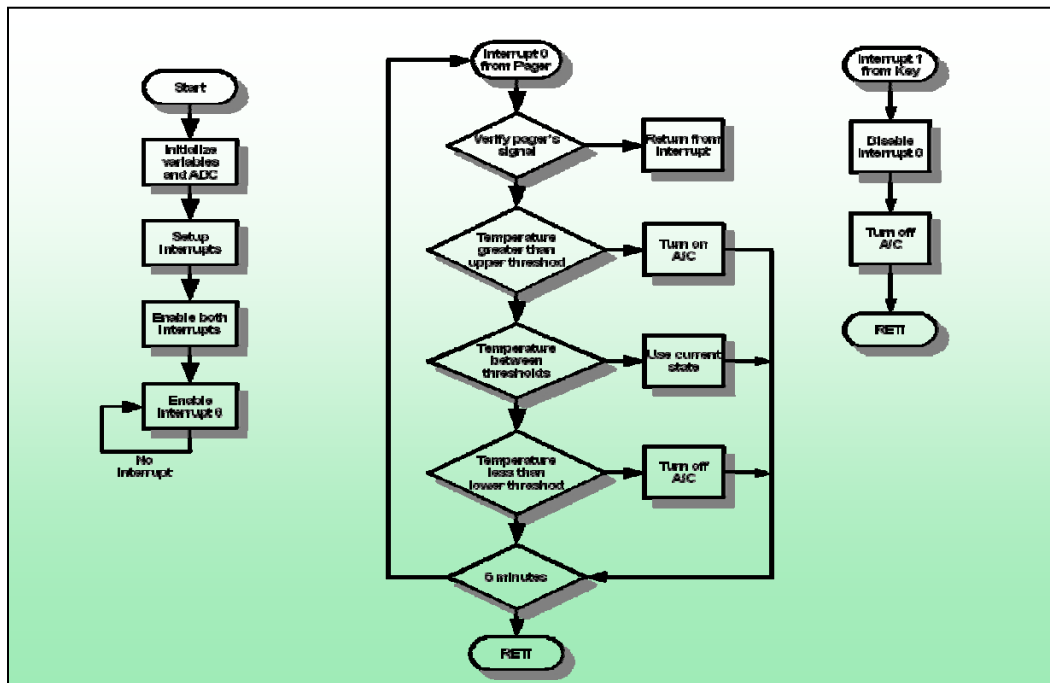

Figure 11. Software Flowchart



The CATS program consists of 3 main sections: the main function which serves as a program entry point, the interrupt service routine (ISR) for pager signal, and the ISR for the key switch or key detection. The main function is a simple function that will initialize all the global variables, baud rate, ADC (Analog to Digital Converter is used to read the temperature sensor), interrupt types, and enable interrupt for the key detection. Following the initialization, this function will run through an endless loop. The pager interrupt will be enabled inside this loop. When a page is received on interrupt 0 (P3.2), the cooling routine will begin after confirming the signal from the pager and checking if the temperature exceeds the threshold. The cooling routine consists of rolling down of the windows, ignition start up and the activation of A/C. This system remains ON for 5 minutes in the flowchart for demonstration purposes. It can be programmed to remain ON for 30 minutes in practical applications. Figures 12 and 13 show the screenshots of sending a message and receiving the message.

Figure 12. Composing and sending a message

Figure 13. Message delivery confirmation

A second external interrupt (P3.3) is used to detect the presence of a key in the ignition switch. If the key is present, the program will run through the second ISR repeatedly until the key is removed, preventing the program from being activated by mistake while the driver is driving.

## Summary and Conclusion

The CATS system has been tested successfully on a 1995 Ford Escort model and has the potential to become an industry standard device that can benefit people in almost every geographic region of the world. This system has been designed keeping in mind the above model and would need some modifications depending on the car model. By keeping costs low, and the driver's interface to the CATS simple and friendly, the system is a useful, highly marketable product. More features can be added to the system such as heater controls, security system integration, and a cell phone based Java application that would allow users to program exact temperature threshold values and activate the system.

## References

1. Jan Null, "Hyperthermia Deaths of Children in Vehicles," <http://ggweather.com/heat/>
2. BiPOM Electronics, Inc., <http://bipom.com/>.
3. TELEPAGE Communications, Inc., [http://www.telepage.com/sun\\_telecom\\_st\\_800\\_plus.html](http://www.telepage.com/sun_telecom_st_800_plus.html)

## Biographies

### TRI (BAO) QUACH

Tri (Bao) Quach is a senior in the Computer Engineering Technology program, College of Technology, University of Houston. He is interested in wireless sensor network for medical applications. Currently he is involved in different undergraduate research projects including interfacing medical equipments, sensors, and mobile handheld devices such as PDA/Smartphone. Besides pursuing his academic career, Bao is also active in many student organizations such as IEEE (Institute of Electrical and Electronics Engineers) and ISA (Instrument System Automation Society).

### LAURA GONZALEZ

Laura Gonzalez is currently pursuing her Bachelors of Science in Computer Engineering Technology, College of Technology, University of Houston and plans to graduate in Fall 2008. She is interested in field of design and project management.

### FARROKH ATTARZADEH

Dr. Attarzadeh is an associate professor in the Engineering Technology Department, College of Technology at the University of Houston. He teaches software programming, digital logic, and is in charge of the senior project course in the Computer Engineering Program. He has developed a concept referred to as EMFA (Electromechanical Folk Art) as a vehicle to attract young students to the STEM fields, and is Associated Editor for student papers at *the Technology Interface* (<http://engr.nmsu.edu/~etti/>). He is a member of ASEE and has been with the University of Houston since 1983.

### MAYURI MAHAJAN

Mayuri Mahajan is currently pursuing her Masters in Electrical Engineering (Majoring in Signal Processing) from the Cullen College of Engineering, University of Houston and plans to graduate in Summer 2009. She is interested in the field of Sound and Image processing, Internetworking, Digital design and Telecommunications. She is a Teaching Assistant in the department of Engineering Technology.