

AC 2008-2077: CNC MACHINING: A VALUE-ADDED COMPONENT OF ENGINEERING TECHNOLOGY EDUCATION

Trian Georgeou, Arizona State University

Trian Georgeou graduated from Arizona State University (ASU) in 2003 with a Bachelor of Science in Manufacturing Engineering Technology. He worked in industry as a Mechanical Engineer while attending graduate school, earning his Master of Science in Technology, concentration of Mechanical Engineering Technology in 2006. While in graduate school, Trian also taught as an adjunct faculty member in Chandler Gilbert Community College's Automated Manufacturing Systems program. Trian worked in the aftermarket automotive industry as an engineering and design consultant for two major companies. Currently, he is a Lecturer in the ASU Mechanical and Manufacturing Engineering Technology Department while remaining active in the aftermarket automotive industry.

Scott Danielson, Arizona State University

Scott Danielson is the Department Chair of the Mechanical and Manufacturing Engineering Technology Department at Arizona State University and has served in this capacity since 1999. He is active in ASEE and several of its Divisions, including serving as 2004-2005 Division Chair of the Mechanics Division. He serves on the Society of Manufacturing Engineers' Manufacturing Education and Research Community steering committee member. He is currently serving on the Technology Accreditation Council (TAC) of ABET, representing ASME. Previously, he had been at North Dakota State University where he was a faculty member in the Industrial and Manufacturing Engineering department. His research interests include machining, effective teaching and engineering mechanics. Before coming to academia, he was a design engineer, maintenance supervisor, and plant engineer. He is a registered professional engineer.

CNC Machining: A Value Added Component of a Mechanical Engineering Technology Education

Abstract

While computer-numerical-controlled (CNC) machining is often a part of a manufacturing engineering technology program, Arizona State University (ASU) believes it is an important, value-added component of its mechanical engineering technology program. Students in ASU's aeronautical and automotive engineering technology concentrations benefit greatly from expertise gained from exposure to this technology. In part, this is because it enables students to live up to the expectation that engineering technology students can both design and build their design. The parts that they design and create are much more complex than those of students that may only have experience with manual machine tools.

At ASU, all students in the Mechanical and Manufacturing Engineering Technology program learn the basics of machining in a challenging manual machining processes course. However in addition, all students take a second course that teaches them the basics of CNC machining. This course is not just a textbook/demonstration course but instead moves students through manually writing CNC code for a two-and-a-half-axis part to using CAD/CAM software to program a three-axis part. In addition to the programming expertise, students individually use a state-of-the-art CNC machine to make each part. Following this course, students have the option of taking a second CNC course that has them make a more complex three-axis part, a mold, and a three-and-a-half-axis mill part (CNC lathe parts are also made by the students). Following this course, students can also take either a high-performance-machining course and or a four- and five-axis machining course.

The paper briefly describes the CNC courses and the software and equipment used by the students. But, most importantly, the paper describes the benefits realized by the mechanical, aeronautical, and automotive engineering technology students from taking these courses. The sophistication of the student's design and build projects in their capstone class has seen a dramatic increase since the students have begun to acquire the CNC machining experience. Thus, the paper builds a case for the value-added aspect of CNC machining within Mechanical Engineering Technology.

Introduction

The authors believe exposing Mechanical Engineering Technology students to a manufacturing processes course sequence in their curriculum improves their ability to design and build. This is currently taking place at Arizona State University's Mechanical & Manufacturing Engineering Technology (MMET) Department where all of the engineering technology (ET) students are required to take a minimum of two manufacturing processes courses.

The MMET department offers two different TAC of ABET-accredited B. S. degree programs; manufacturing engineering technology and mechanical engineering technology. The manufacturing engineering technology degree offers a manufacturing concentration or a mechanical concentration while the mechanical engineering technology degree offers four

concentrations: mechanical, automation, automotive and aeronautical. Both degree programs contain the traditional engineering science classes associated with the degree and/or concentrations, along with a large world-class engineering technology lab experience. However, these curricula also include machining courses.

Manufacturing-related knowledge is also included in the Mechanical Engineering Technology program objectives and outcomes (thus important to the program's ABET accreditation). One of the five Mechanical Engineering Technology program objectives is "Basic knowledge of production processes so designs take manufacturability into account." Specific program outcomes include: "understanding of the behavior and properties of materials as they are altered and influenced by processing or manufacturing" and "an ability to apply creativity in the design of systems, components, or processes." The various manufacturing courses and projects embedded within the program allow the faculty to both teach the students the necessary knowledge as well as access the student attainment of those outcomes and objective. The latter outcome above is directly impacted by the CNC machining courses.

Students from both the mechanical and manufacturing engineering technology programs are required to complete a series of machining courses that increase the student's design-for-manufacturability (DFM) knowledge. Providing students with a hands-on approach when teaching machining classes in the ET curriculum enables students to become aware of how their design, dimensioning and tolerancing can drastically influence the downstream manufacturing processes. This is especially helpful for students in the aeronautical and automotive concentrations as they have a high probability of designing parts that will require machining processes during their manufacture.

In industry, having mechanical and manufacturing engineers "cross-train" is not a new concept. When mechanical engineers understand machining and manufacturing processes, they are able to make more educated decisions during the design process. This reduces the time it takes for the product to reach the market, ultimately saving the enterprise money. The MMET manufacturing processes courses ultimately give the students valuable DFM knowledge while, simultaneously, making them more marketable graduates. This paper describes the machining courses offered within the MMET Department and describes how these courses have lead to successful design-build projects in the mechanical engineering technology curriculum.

Mechanical & Manufacturing Engineering Technology's Machining Curriculum

The courses offered include a basic manufacturing processes class where students learn how to use a manual mill and lathe and an advanced course where students learn the basics of CNC programming. Both courses are required for all mechanical engineering technology students. In addition to these courses, students may take three more advanced CNC courses as technical elective credit. These advanced courses contain topics such as advanced three-axis surface milling, high speed machining, and fourth- and fifth-axis simultaneous programming.

Two primary labs devoted to the machining processes support the machining curriculum. First, the manual processes lab is a 1300 ft² lab with five manual vertical mills and five manual lathes with a surface and cylindrical grinder, sinker die electronic discharge machine, and tool grinders

and sharpeners. The second machining lab is the 1400 ft² Haas Technical Center. The Haas Technical Center contains the following four CNC mills: VF-2 SS 3-axis mill, VF-2 mill with four-axis rotary table, VF-3 mill with a five-axis trunion table and an OM-2 office mill with 30,000 RPM spindle. The technical center also contains CNC lathe capability with a SL-20 CNC slant bed lathe and a TL-1 tool room lathe. The Haas Technical Center always has state-of-the-art CNC equipment due the relationship with Haas Automation Inc. Therefore, all mechanical and manufacturing ET students work on up-to-date equipment and gain CNC programming and setup experience along with machine time experience.

The first machining course, MET 231, Manufacturing Processes, provides machining basics and provides a foundation for the CNC courses. This course is typically taken in the fall semester of the mechanical ET student's sophomore year. The manufacturing processes class is a laboratory/lecture class where students learn theory about manufacturing processes in the lecture and perform hands-on machining projects in the lab. The lab section is separated into two different projects, a mill and a lathe project. This is where ET students first learn the impact of design on manufacturing.

During the first half of MET 231 lab, students use manual vertical and horizontal mills along with surface grinders to manufacture a miniature vise (student drawn Solid Edge assembly model in Figure 1). The vise project introduces students to the functionality of mills where they learn how to effectively operate a manual mill, machine a part to a geometrically-dimensioned and toleranced print, and gain experience calculating feeds and speeds for the different types of materials. Not only do students learn the how to operate a manual lathe, they also learn about tolerance stacking. As a result, students gain a better understanding of how part tolerances can accumulate and affect the final assembly. In fact, some parts are intentionally made to unnecessarily tight tolerances (plus or minus 0.005") to illustrate the impact of such design decisions.

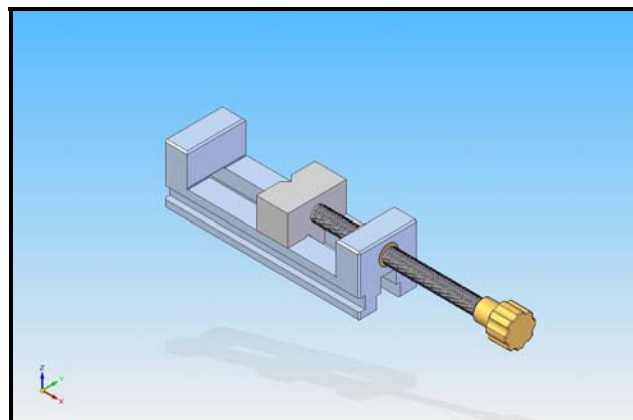

Figure 1. MET 231 Vise Project

During the second part of the semester, following the completion of the manual mill project, students begin their project on the manual lathe. In this section of the course, the students use a properly formatted engineering drawing to build a screw jack. This project provides students the opportunity to learn how the lathe functions along with how different materials machine. Every

week in lab, students complete a part of the screw jack, as shown in the assembly drawing in Figure 2. Once all of the screw jack components are machined to print, the students are required to create manufacturing routings and first article inspection sheets for the individual parts.

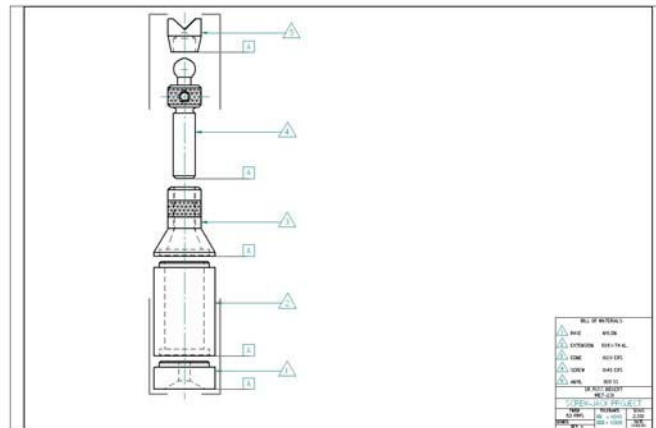

Figure 2. MET 231 Screw Jack Exploded Assembly View

Once students gain basic understanding of the manual vertical mill and manual horizontal lathe operation, students take the second machining course, MET 345, Advanced Manufacturing Processes. This course is a lecture and lab course introducing students to machinability of materials, manual computer-numerically-controlled (CNC) mill programming, CNC lathe programming, along with computer-aided-design (CAD)/ computer-aided-manufacturing (CAM) CNC programming of mills and lathes. For the mechanical engineering technology students, this is the final required machining course. During the lab section, students are required to program, setup, and run their assigned CNC projects. Having to program, setup, and run their own CNC part teaches students which kind of operations can be performed on a vertical CNC machining center and horizontal CNC lathe. This knowledge is especially important for aeronautical and automotive ET student graduates who will have a high probability of designing parts manufactured on similar machines.

Throughout the first five weeks in MET 345, students perform five different machinability labs, using an engineering approach. The main purpose of the machinability labs are to teach students how to approach the calculation of speeds and feeds for machining different materials on a manual lathe and on a Haas VF-2 vertical CNC mill in an organized, formalized manner using appropriate references. During the first machinability lab, students are taught to grind a HSS tool blanks and machine heavy roughing cuts in mild steel with an acceptable surface finish and tool life. This first lab teaches the ET students how the tool angles, cutting speed and chip load, affect the surface finish, chip formation and power required to make the cut. In the next two machinability labs, students use carbide Kennametal inserts to machine 304 stainless steel and 718 Inconel. In addition, students calculate the feeds, speeds, and horsepower required to take a heavy roughing cut in these materials. During the first three machinability labs, students gain an understanding of how chip load and surface speed are related to a material's composition, microstructure, and hardness. The last two machinability labs are milling and drilling labs. In these labs, students master relationships between chip loads and surface speed for different

exotic materials such as titanium. This machinability section prepares students for CNC programming and enables them to feel more comfortable with the RPM and feed specifications specified in the programs.

In the lecture part of the class students are introduced to manual G and M code programming. During the lab, students are tasked with building a CNC business card holder as pictured in Figure 3. The CNC business card holder is a two set-up part. The students manually program the first set-up operations while the second set-up operations are programmed using SurfCAM, a CAD/CAM software package.

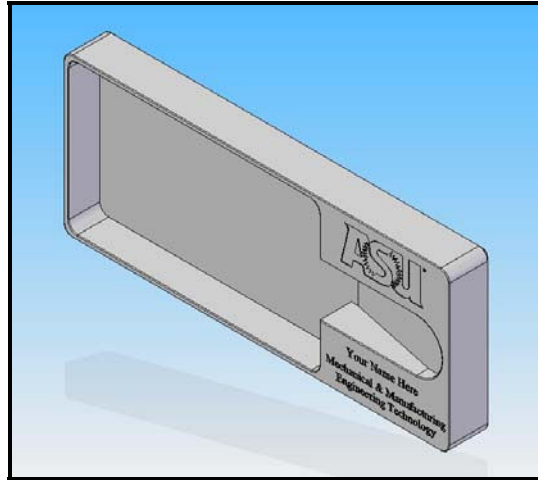

Figure 3. MET 345 CNC Business Card Holder

Students start preparing the business card holder's first setup operations by writing a simple two-and-a-half-axis program to machine the outside profile as pictured in Figure 4. The students are given a part print with a tool list and asked to create toolpath drawings for each machining operation. These drawings assist the manual toolpath programming and help with program troubleshooting. The students write the CNC code, setup the CNC mill, and machine their first operations for the part.

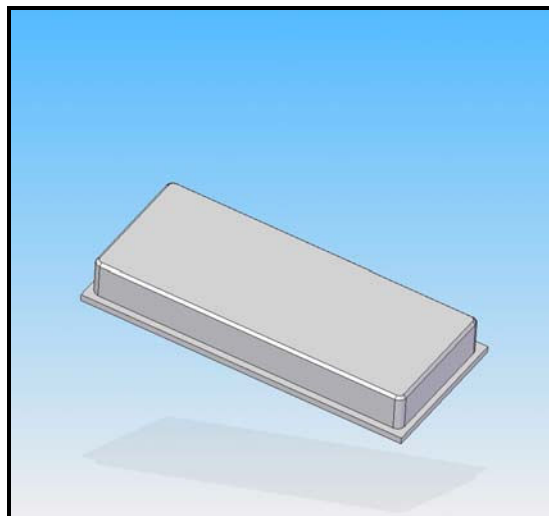

Figure 4. MET 345 CNC Operation #1

After the first manual CNC programming lab, students are introduced to SurfCAM, a software package that can generate CNC toolpaths for mills, lathes, plasma, electronic discharge machines, and coordinate measuring machines. During the lecture portion, students learn how to draw and import CAD models into the SurfCAM program. Using the wire frame model generated from the part print, students create CNC toolpaths in SurfCAM to machine the second operation of the business card holder. Using this software, students also have an opportunity to customize their business card holder with their own name. A SurfCAM screen shot of the CNC project is shown in Figure 5. This lab teaches the mechanical engineering technology students about machining and inspecting parts from properly datum dimensioned prints as seen in Figure 6. Finally, upon completion of the CNC business card holder labs, the students have to submit a technical engineering report documenting the procedure used to create and inspect the part.

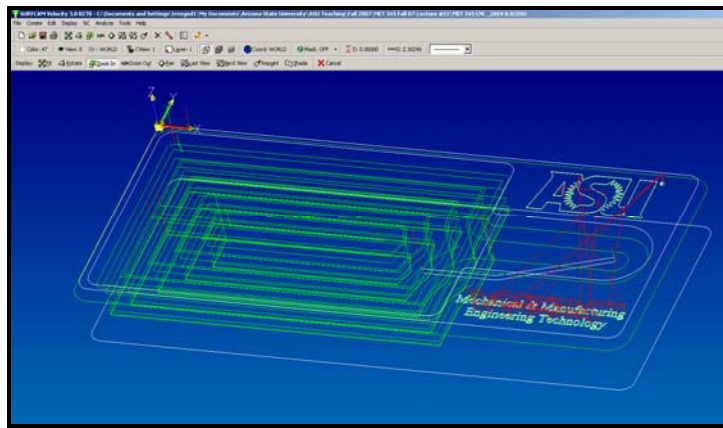

Figure 5. MET 345 SurfCAM Screen Shot

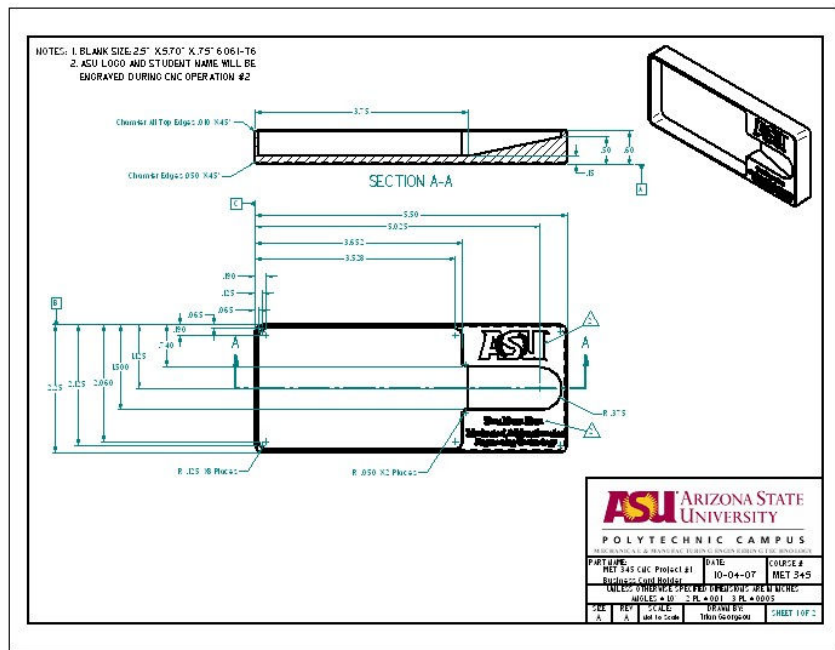

Figure 6. Business Card Holder Part Print

The final lab in MET 345 is a CNC lathe part project. In the lecture component of the class, students are taught to manually program a CNC lathe and, in the laboratory section, students use SurfCAM to program the Haas TL-1 CNC lathe. Over the course of this project, students make a widget that incorporates the following main CNC lathe operations: facing, turning, grooving, and parting off. The students are given an engineering drawing and, from the drawing, they use SurfCAM to create the geometry needed to create the CNC lathe toolpaths and program the part. A picture of the solid model of the MET 345 CNC lathe part is shown in Figure 7.

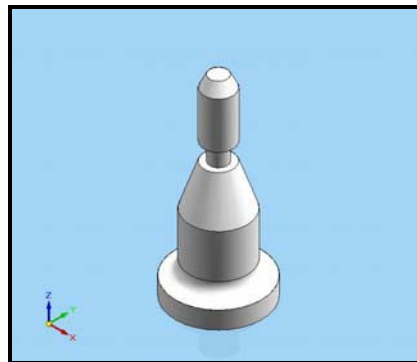

Figure 7. MET 345 CNC Lathe Part

The next machining class, MET 443, CNC Programming, can be taken as a technical elective for the mechanical engineering technology students. The course is a lecture-lab course where the instructor lectures on advanced CNC topics during the lecture time and during the lab students perform three different CNC projects and a final CNC production part project during the lab time.

The first lab project is a CNC aluminum mold project that initiates the students into full simultaneous three-axis CNC machining (see Figure 8). During this CNC mold exercise, the students create surface models along with the wireframe models. The mold surface models are used to drive simultaneous three-axis toolpaths in SurfCAM. Students are encouraged to compete with one another in an attempt to create the mold project with the best surface finish and lowest machine cycle time.

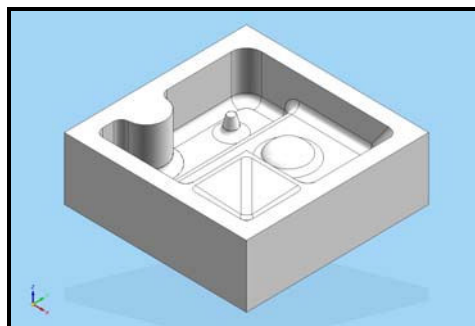

Figure 8. MET 443 Mold Project Solid Model

Once the students learn how create three-axis surface machining toolpaths, they are introduced to three-and-one-half-axis index machining using a four-axis rotary table. The students learn how to position the fourth-axis to make the part pictured in Figure 9. The students use SurfCAM coupled with a HAAS four-axis rotary table on a VF-2 mill to perform this project. During the third CNC project in MET 443, students are tasked with a more advanced CNC lathe project, an automotive hose fitting. The automotive hose fitting gives the students the chance to program a lathe part that has multiple operations.

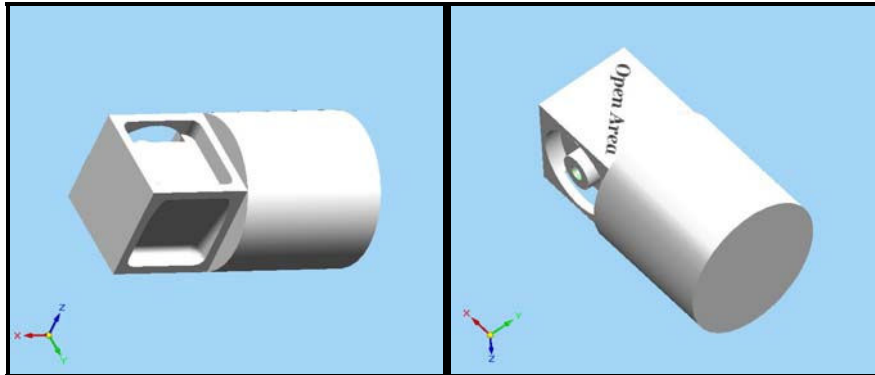

Figure 9. MET 443 3½-Axis CNC Part

Once the students have performed the first three CNC labs successfully, they have a chance to use their CNC programming skills, acquired in the three previous machining courses, to create their final project part. The students are assigned a final CNC production part project in the course, requiring them to design and manufacture a multiple operation CNC part. In addition, determining the production cost of the product is discussed. Thus, the CNC labs incorporate all elements that a mechanical engineering technology student should possess to support a design and build skill set. These laboratory projects range from CNC billet aluminum radio controlled (RC) car wheels to three-dimensional billet aluminum license plate plaques. The following figures demonstrate final projects from the CNC Programming class: Figure 10 includes a SurfCAM screen shot of a RC car wheel and then the final machined part.



Figure 10. SurfCAM RC Billet Monster Truck Wheel Surface Model & Part

In Figure 11, a screen shot of SurfCAM toolpath for CNC billet pool sign, and the resulting machined CNC billet pool sign (Figure 12) are examples of student work.

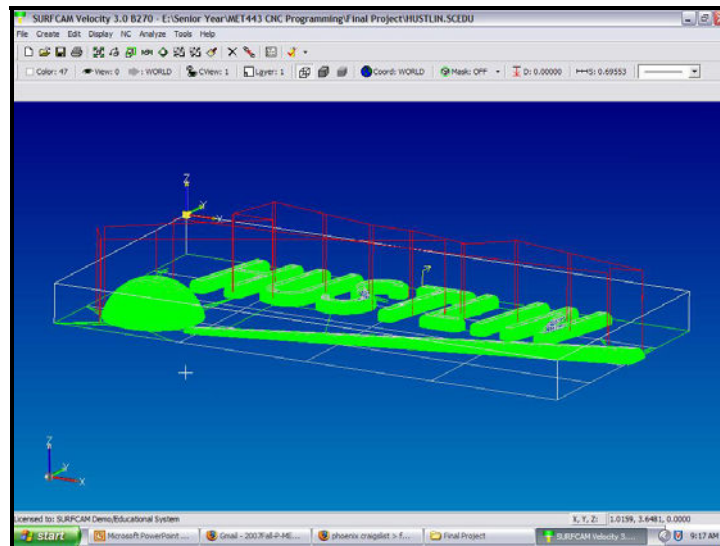

Figure 11. SurfCAM Toolpath File for CNC Billet Pool Sign



Figure 12. Student Designed & Manufactured CNC Billet Pool Sign

After completing the CNC Programming class, exceptional undergraduate engineering technology students have the opportunity to take two different graduate level special topics CNC courses, MET 598, High Speed Machining and MET 598, Simultaneous Fourth- and Fifth-Axis Machining (upon instructor approval, senior undergraduates are allowed to take graduate level classes and use them towards their B.S. degree). The projects in these classes include a four-axis turbine blade project, a five-axis simultaneous compressor wheel, and generating empirical high-speed-machining data from the different Haas machines. In the fourth- and fifth-axis CNC class a centrifugal compressor wheel is machined, see Figure 13.



Figure 13. 5-Axis Centrifugal Compressor Wheel

CNC Machining Influencing Engineering Technology Student's Designs

At the culmination of the mechanical engineering technology student's degree, all students are required to complete a two semester capstone design course. During the first semester of the capstone course, the students are presented with an engineering problem and are tasked to engineer and design a solution to the problem. In the second semester of the capstone course, the students build their design, created in the first semester. The deliverables from Arizona State University's capstone courses have validated the hypothesis that the machining courses give the mechanical ET students better design skills. The capstone courses continuously produce products that are industry quality with projects adopted by sponsor companies and placed into operation. Students also create parts and systems that allow them to do such things as build a vehicle to compete in SAE Mini Baja competitions.

Having a background in machining helps Mechanical ET students determine how products should be designed and manufactured and which types of features cannot be produced on traditional manufacturing equipment. This point is illustrated below in Figure 14 and Figure 15. Figure 14 shows an ET student's design for an SAE Mini Baja rear drive knuckle while Figure 15 shows the final machined part. The student was able to take his solid modeling class experience, a class required for all mechanical ET students in their curriculum, and design a rear knuckle for their SAE Mini Baja car project. Not only did the student design the knuckle; he used SurfCAM to create the CNC machine code for the part. Without the hands-on machining courses, the student would have had to outsource his design to a local machine shop. Machining has proven to be an effective component in mechanical engineering technology education.

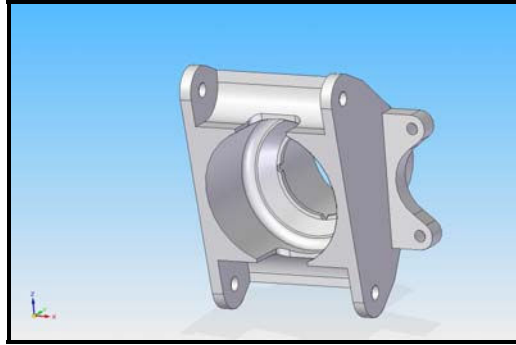

Figure 14. SAE Mini Baja Rear Suspension Knuckle Solid Model



Figure 15. SAE Mini Baja CNC ET Student Designed & Machined Part

Conclusion

CNC machining is usually part of a manufacturing engineering technology major's curriculum. However, it is not usually part of a mechanical engineering technology student's program of study. Having mechanical ET students take a sequence of machining courses has proven to be a value added component to their ET education. At Arizona State University (ASU), both mechanical and manufacturing ET students are required to take a minimum of two machining courses, one being a computer numerically controlled (CNC) machining course. Once they complete the two required courses the students have the opportunity to take three more advanced CNC machining classes for technical elective credit. Having mechanical ET students exposed to these types of courses greatly aids their design for manufacturability skills and ultimately empowers students to design and build better machines. Cross-training mechanical and manufacturing engineers have been going on in industry for the past 20 years. Therefore, this added component of the curriculum is regarded favorably by employers. The machining courses at ASU especially give the Mechanical Engineering Technology's Aeronautical and Automotive concentration students a distinct advantage over the typical mechanical ET student that does not have hands-on exposure to more advanced machining courses.