

## Data Acquisition and Control of Microgrid Using ZigBee – A senior design project

Scott G. Gabert, Jeff C. Kaiser, Derek J. Snyder, Prakash Ranganathan and Reza Fazel-Rezai

*Abstract*—This paper describes a novel switching mechanism to acquire data and control a microgrid. The grid operates in two distinct modes; Islanding and grid-connected modes. In islanding mode, the circuit should be able to isolate sections of the grid when the electrical grid experiences failure. In grid-connected mode, the microgrid has to supply and maintain the power balance to critical loads. Solar panels act as one of the Distributed energy resource (DER). Batteries are also used as an energy source when grid power is and the DER's are unable to supply the necessary power for critical loads. The switching is all be automatic with LabVIEW controls, and the ZigBee sensors will remain powered even if grid power is lost in order to complete switching. The concept of acquiring data from ZigBee sensors and switching mechanisms using MOSFETs to control the network are described in this paper.

### I. INTRODUCTION

The growing demand to make the electrical grid as efficient as possible has been a continuous effort through the years. A microgrid is a distributed system that represents, physically, a small-scale electrical grid, and demonstrates how the system can support the demand of both industrial and communal needs. Microgrids are an ideal way to integrate renewable resources on the community level and allow for customer participation in the electrical system. A key advantage is that the microgrid appears to the power network as a single controllable unit, enabling it to deliver the cost benefits of large units. The microgrid can function in conjunction with the grid, using its own energy sources when necessary. In the event of grid failure, the microgrid can island and act independent of the grid system unaffected by the failure. In the event that the DER's are unable to provide energy for the demand, the grid is able to make up for the additional demand of the load. In addition, some microgrids have batteries that charges from the DER's during peak generation times, and can be used when operating in islanded mode [1] Furthermore, microgrids can enhance local reliability, reduce feeder losses, provide reactive power and local voltage support, remove transmission and distribution bottlenecks, increase efficiency through combined heat and power (CHP), and provide uninterruptible power supply functions [2] [3]. The main goal of the project is to develop microgrid control that delivers power in the event of line failures, thus increasing reliability. The secondary goal is having the ability to island the critical from the non-critical loads using a ZigBee wireless network.

The “higher priority” loads are therefore supplied with no disruptions in the event of any failures. Supplying these high priority loads is an essential objective in our microgrid during these failures. To accomplish this objective, a battery bank is used in combination with solar modules to supply the grid when the main line fails. The main usage of the solar power is to supply the grid with green energy when there are adequate generation capabilities, and to also supply the battery bank as a recharging circuit when the main grid is up and running. The solar panels were deemed inappropriate as a primary power source for such a small-scale system due to negligible power output. The solar cells do however supply enough power to support a select amount of loads or critical loads during the microgrid's islanding mode. The use of a wireless network to control MOSFETS to switch between the islanding and non-islanding modes is an efficient method in keeping critical loads supplied with power at all times with the use of renewable energy.

## II. HARDWARE- METHODS AND MATERIALS

### A. Hardware Layout

The basic hardware for the grid was constructed to mimic many different types of loads that are present in the world around us. In the design, there are resistive loads of LED's and incandescent bulbs as well as two different motor loads

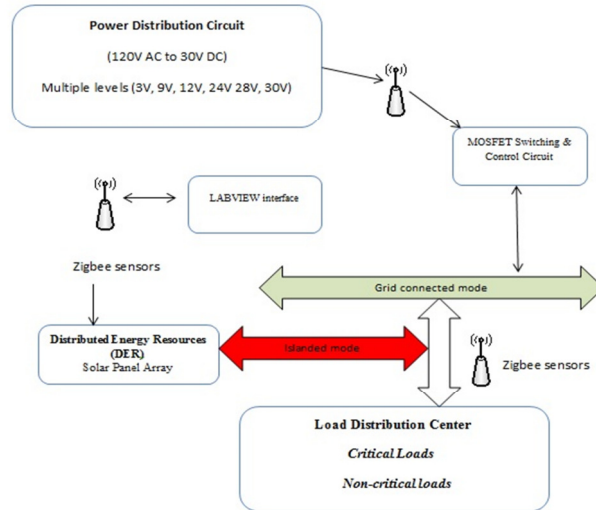

Fig. 1. Block Diagram of ZigBee controlled microgrid

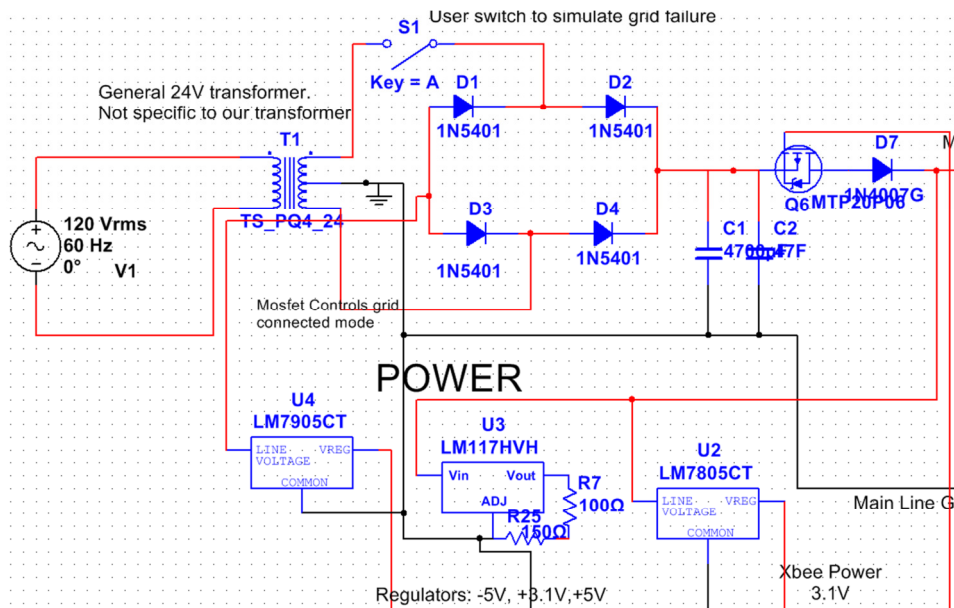

Fig. 2. Hardware layout of the power distribution circuit

to show the effects of apparent power in the circuit. In addition to the loads on the grid, there are two external loads: 1 mini USB for cell phone charging and one other external port. One of the limitations of the circuit is that the power in the circuit is all DC power. The reason for this is because with the

Distributed energy resources (DER's), inverters would be needed to create an AC voltage. These would be large and costly, and are irrelevant for the purpose of this project.

### B. Hardware Configurations

The ZigBee controls (discussed in the software section) is able to activate and deactivate different parts of the circuit depending on which mode the circuit is operating in. When operating normally, grid power supplies the loads through a transformer and rectifier. This is referred to as grid connected mode. If partial or total power is lost, the grid automatically changes to islanded mode, and operates solely on its backup battery power and solar panels. The solar panels will continuously charge the batteries, so that power is available if it is needed [5].

### C. Hardware Components: Power circuit

The main power distribution circuit in grid connected mode consists of a transformer, full wave rectifier, and capacitors to convert the 120V AC power to approximately 19V DC power. The maximum power draw rating of the transformer is 30VA. The rectifier used is a 50V, 3A bridge rectifier, and its ripple is reduced by two 4500  $\mu$ F capacitors.

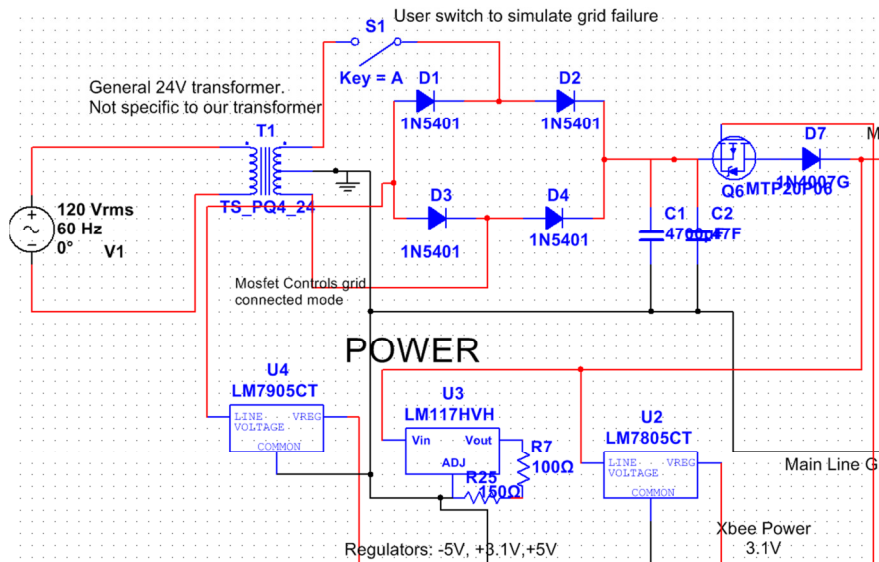

When all loads in the system are off, the voltage is 19.1V. When all loads in the grid are on, the voltage is reduced to 16.6 V, and a current of 0.33A for a power consumption of 5.47 W. In this configuration, the voltage ripple is 150mV, which is too great for the Xbee sensors used (maximum 100mV ripple). Therefore, a variable regulator which has been configured to 3.1V, is used so that the power ripple does not damage the Xbee sensors.

In addition, when the larger motor becomes loaded (Motor turning is resisted by force) the voltage output of the power circuit drops to 14.5 V and the current rises to 1.05A, for a total power consumption of 15.23W. Four grid loads and one external load are being used, which brings the maximum total power draw close to 30VA, a value that will be closely monitored so that the transformer is not damaged by overdrawing the power.

From the main power circuit to the rest of the grid there is a physical switch that the user can control. This switch is used to simulate a grid failure. If the switch is flipped, power to the microgrid is lost. When this happens, the MOSFET, which connects the grid power to the main line, goes into cutoff so that the circuit can use its own power in islanded mode. This MOSFET is MTP23P06V power MOSFET, which is rated to 23A at 60V. When the grid needs to be operated in islanded mode, this MOSFET operates in cutoff by applying a voltage to the gate, which cuts off the grid connection to the circuit.

#### D. Hardware Components: Microgrid Loads

The basic hardware design for the microgrid is shown in Fig. 2. The BS170 (for LED and incandescent loads) and the IXTH67N10 (For the motor loads) are N-channel enhancement MOSFETs, which are controlled by the ZigBee sensors. Because the output of the Xbee sensor is only 3.1V, and the MOSFET required 4V to be placed in the saturation region, the TL074CN JFET amplifier is used to increase the voltage of the Xbee output to turn on the amplifier. This amplifier requires +/-5V to operate. The source of the negative voltage is from the negative side of the transformer.

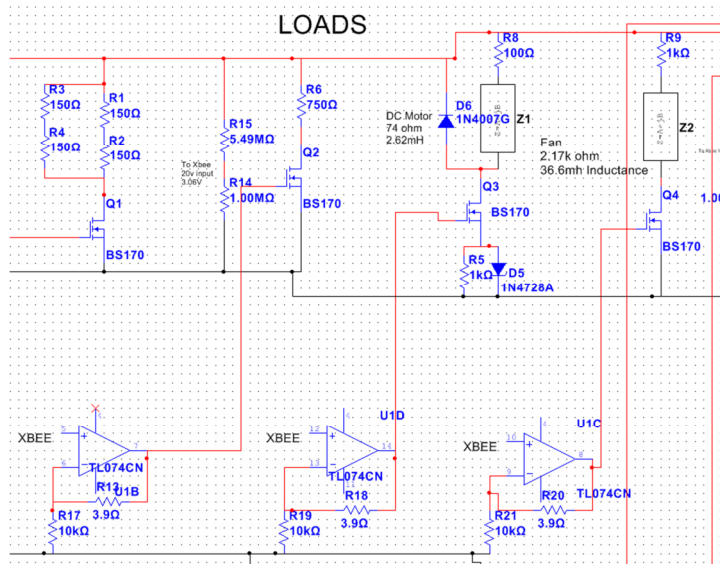

Fig. 2. Load setup in grid testing

The positive side acts as +19V, while the center tap is grounded. The amplifiers are supplied with the necessary voltages through voltage regulators. If the MOSFET gate is driven high, then the switch is “closed” and power is provided to that section of the circuit. The ZigBee sensors chosen are the Xbee Pro 802.154 sensors by Digi. As stated previously, the ripple for the Xbee Pro is 100mV, so regulators are used to ensure clean power to the Xbee’s. These sensors were chosen because of their low cost and low power consumption [4]. Three of these sensors (each with 8 I/O ports) are used to gather grid data and control the MOSFET switching. The Xbee sensors are connected wirelessly to the Xstick 802.15.4, which is operating in API mode as described in the software section. In normal mode, the Xbee sensors have all MOSFETS in the “on” region of operation.

The loads that are supplied in this mode are 4 incandescent bulbs (4 X 0.6W = 2.4W total), 1 LED (1.5W), and 2 DC motors which maximum power of 1.5 and 5 Watts, respectively, which also depend

on the motor loading. The larger motor load also uses the MOSFET IXTH67N10 because the large inrush current from the motor will be above the rated value of the smaller BS170 MOSFETS.

The motor loads must have a 5V Zener diode between the gate-source junctions, so the voltage does not build up across this junction as shown in Fig.2. An additional diode is placed between the drain and V<sub>dd</sub> of the circuit to prevent any back emf from building up when the MOSFET is turned off.

If the physical switch to the grid connected mode is turned off, the grid will lose its power. The Xbee's will also lose power. Therefore, PMOS transistors are used to allow the battery voltage to supply power to the circuit, rebooting the Xbee's so that further switching can be done. The battery banks are then be activated to power the critical loads (two loads have been selected as critical: the small motor load and the LED). The other loads, including external load are turned off.

For the external load, a micro USB cable will be attached to provide power to a cell phone (which operates at +5V DC). This will be considered a non-critical load and will be shut off in the event of a partial or complete power failure. This too, will be switched on and off by N-MOS transistors. There is a voltage input to one of the Xbee pins so that the Xbee can send the line voltage to the XCTU software, which will eventually be seen in LabVIEW for greater grid visibility. A simple voltage divider, consisting of a 5.2 M $\Omega$  and 1M $\Omega$  resistor, will be used so that the voltage is stepped down before being sent to the Xbee. At maximum line voltage of 19.1V, this means only approximately 3.1V will be sent to the Xbee. The Xbee cannot perform analog to digital conversions above its input voltage of 3.1V, which is why a voltage divider will be used to step down the voltage from 0-20V to 0-3.1V. In the LabVIEW program, the voltage will display at 0 to 19V, so that the actual line voltage can be known for grid visibility and the operate between islanded and grid connected mode

#### *D. Hardware Components: Distributed Energy Resources*

The DER's consist of solar panels and a battery bank. They operate in conjunction with one another when the system is running in islanding mode and as a supporting unit when the system is non-islanding. When there is adequate sun available to be dependent primarily on solar energy, the system has the ability to function mainly off of the solar cells and supply select loads. These selective loads can be labeled as critical loads or loads that need to be supplied 24/7 if grid connected mode fails. In the event of inadequate sun energy, the system shift to a battery bank based system. The microgrid's method of shifting is conducted using a ZigBee node to both sense the solar panel output and switch the appropriate MOSFET between the two DER's.

In grid connected mode the solar panels are used to continuously recharge the battery bank, which consists of two 9V batteries. The panels are only able to recharge the battery bank when the panels are receiving satisfactory sun light.

The DER circuit uses 3 PMOS transistors (MTP23P06V). The reason for this is because when grid power is lost, all power is lost to the Xbee's, which will be unavailable for switching. However, when the grid loses power, the gates to the PMOS transistors also lose power, which allow the MOSFETs to operate in the saturated mode, so they are able to power the Xbee's. From there, additional loads can be switched off to conserve power and the MOSFET between the main line connection and the grid power can be placed into cutoff by supplying a voltage to the gate.

This brings several more considerations to the design process of the DER's. First, if the solar panel voltage is too high, then the voltage applied to the gate may not be enough to put the MOSFET into cutoff. Therefore, the solar panel voltage must be regulated through the LM317 positive voltage regulator to 20 V. Another design consideration is how to power the amplifier to apply adequate voltage

to the gate to cutoff the transistors. When completely loaded, the main line voltage of the circuit decreases to about 15v, which is below the 16.5-17V that needs to be applied to the gate. Therefore, the amplifier supply voltage that is used to increase the Xbee voltage, which puts the MOSFET into cutoff, is supplied by the batteries. In addition, a single supply amplifier is used as it has a lower power draw and because the dual supply amplifier cannot support the voltage required by the amplifier (TL074CN can only support a 32v differential, which is smaller than the +/- 18 volt differential that would be required for the dual supply). The CA3401 single supply amplifier has been chosen because of its ability to handle high voltages and its lower power consumption.

Another advantage in using the PMOS transistor as opposed to the NMOS transistor is that both the solar panel and battery are grounded in the same spot, instead of having NMOS transistors between the main line ground and the source ground. This was not initially evident, and when the circuit was constructed this way, many problems arose with the several different grounds, which could have potentially caused damage to circuit components. Therefore, even though the gate voltage of the PMOS for cutoff must be higher than that of the gate of the NMOS for saturation, the design is more reliable.

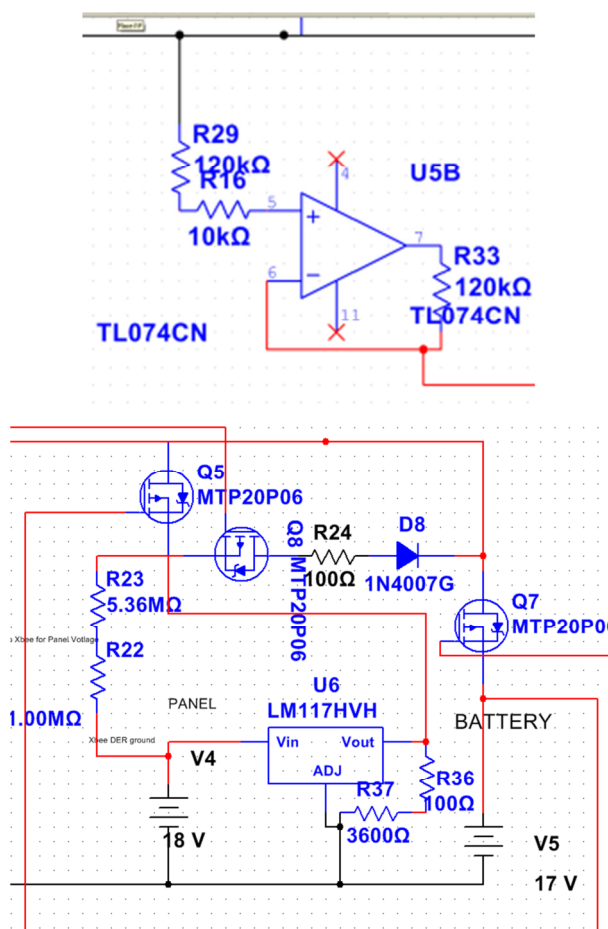

Fig. 3. DER placement and cutoff circuit

Mode	Transistor in Saturation	Power source
Grid-Connected	Q8	Main Grid (Batteries charging from panels)
Islanded	Q7	Battery
Islanded	Q5	Solar Panels

Table. 1. DER Modes

Some of the most difficult hardware challenges encountered are with the single supply amplifier. This device had not been used before, and though it operates similar to traditional dual supply amplifiers, there is some difference with the voltage that needs to be supplied. Another difficulty with the hardware was trying to integrate the solar panels and batteries into the circuit. To have the panels charge the batteries as well as to have the batteries or the panels operate the grid was a difficulty. As the above circuit shows, 3 PMOS transistors and a regulator were used to ensure that the switching would operate correctly. These problems were solved with the above circuitry, but not without much trial and error. Though there were issues with the hardware implementation, the design works as intended and switching as able to be completed.

### III. SOFTWARE – METHODS AND MATERIALS

National Instruments LabVIEW software was chosen to control the switching between grid connected and islanding modes during main grid failures, and in addition the critical and non-critical loads. The network hardware includes the Xstick and Xbee modules. The Xstick is being used as the Xbee coordinator and the Xbee modules as routers that will be arranged in a mesh configuration. To better accommodate the operator the group felt that a visual interface through LabVIEW would be the most ideal. In order to connect the Xbee coordinator to LabVIEW, a serial-input VISA block must be utilized. X-CTU software, which is available free online, is used primarily to interface the Xstick with the Xbee's for various actions such as data acquisition, as an example, but can also be used for sending HEX code packets to communicate with the Xbee modules. Once the desired boolean case value for the switch is selected in LabVIEW or entered in through a HEX packet in X-CTU, it transmits a signal from the Xstick wirelessly to the mesh network of ZigBee sensors. This transmitted signal is then received by the desired Xbee in the network which then outputs its desired digital high or low voltage value.

After Xbee receives the signal for digital high, it will output positive three volts that will in turn be adjusted for the MOSFET specifications for turning the MOSFET on, and when Xbee registers digital low a voltage of zero will be directed to the gate of the MOSFET switching it off. The voltage required by the MOSFET to put it in the conduction region is around five volts for this specific project.

When address the pins on the Xbee that corresponded to each MOSFET, a packet compiler is used to create a HEX code that will exploit X-CTU to send this packet to the Xbee. The X-CTU software confirms the successful packet was sent and received. If the packet is incorrect or the address is incorrect, X-CTU will not have a response indicating that the packet did not register. This compiler is a user friendly interface available through the manufacturer, Digi International, Inc. The indoor distance restraint found after testing was about 100 feet. This is less than what the Xbee sheet specifies because the restraint is the distance that the Xstick can transmit. The data sheet for the Xstick was not available

due to the product being so new.

The Xstick was selected to operate in Application Programming Interface (API) mode through the settings in X-CTU. This mode allows greater flexibility and the ability to program the ZigBee sensors wirelessly. API mode allows the Xbee's to coordinate with other ZigBee sensors and components, in this case, the Xstick rather than AT mode which is only point to point transmission. If AT mode were used, it would not allow the Xstick to send different commands to the Xbee modules as the coordinator. This operation is being used to switch between the grid connected and islanding modes on the micro grid.

The primary use the LabVIEW interface is to better accommodate the operator of the system. It displays several switches in the form of buttons on the front-panel window of LabVIEW to visually make the switching operation user friendly. The control interface in LabVIEW makes use of a while loop structure as its foundation to embed assorted Boolean case structures to control the switching processes that the operator is selecting in the front panel. To send the HEX packets when a switch is selected, a write buffer control is connected to the VISA write block in block diagram. This buffer is then connected through each case structure, VISA read block and through the remaining while loop for when the loop starts over in the beginning of the program is knows what the previous output was. If the input has not changed, it sends the same high or low signal to that pin to ensure that it stays at that setting. Each button is designated to a specific MOSFET switch on the board, which makes controlling of the loads simple.

The switching response time is calculated from the moment when LabVIEW sends the signal to the MOSFET that is performing the action is calculated using the difference between two times recorded at different portions of the main while loop. These times are analyzed within a for loop and then sent and logged into an excel spreadsheet for easy viewing. The baud rate of the Xstick is also analyzed to ensure the quickest and most efficient transmission. Baud rate is the rate of transmission and is adjusted and optimized for the appropriate data being transmitted. The lower the baud rate, the farther range of transmission, but the bandwidth of the data will be small with the lower baud rates. As an example if a larger amount of data is desired for transmission, a larger baud rate would be ideal, but the distance will, as a result, suffer. This will be useful for practical applications as switching is a very important part of keeping power flowing.

The ideal baud rate that was selected for this project was 9600bits/sec. The reasoning behind choosing this value was simply due to a constraint that was observed from the Xstick. Because the Xstick technology is fairly new, a data sheet entailing the specifications was not found. The baud rate 9600 could not be adjusted, so if another baud rate setting is required or needed the Xstick would not be the appropriate candidate for this task. An Xbee module would be the ideal contender to be used as the network coordinator in place of the Xstick allowing a greater range of adjustability.

#### IV. BUDGET

The total project has cost \$196.80, as shown by Fig. 3 . Initially, \$400 was expected for the project, but the department provided us with \$200. Therefore, we used all of the budget, though a larger budget could have led to more functionality.

<b>Budget Report</b>	
<b>Item Received</b>	<b>Cost</b>



USB cable for ZigBees	\$3.99
Xbee usb adapter	\$23.99
Xstick 802.15.4	\$49.00
Xbee sensor	\$36.99
Transformers	\$33.32
Shipping/Tax	\$9.51
PCB	\$40.00
BS170 Mosfets	\$0.00
Bulbs/LED's	\$0.00
DC Motors	\$0.00
Zener Diodes	\$0.00
<b>Total Spent</b>	<b>\$196.80</b>

Fig. 4. Up to date budget usage.

## V. RESULTS

The Hardware design has been completed with all components functioning, with the exception of one part. One of the ports on the Xbee cannot be turned high or low, but rather floats at about .3V. This port operates the larger DC motor, and when the company was contacted about the issue they claimed that this was an unknown hardware error. This problem could be solved with another Xbee module, which would allow the motor to be turned on and off correctly.

As for the other hardware in the circuit, the main line voltage of 19.2 V unloaded and approximately 16 volts loaded means that the test loads all receive adequate power to run normally. When switching the battery, the battery voltage actually decreases to about 15V ( Down from the fully charged 16.8V). However, the battery still supplies enough power to operate the Xbee and loads. There were a couple jumper wires that needed to be used due to pin misplacement on the PCB, but this could easily be solved by making the design corrections and having another PCB printed. The nominal power consumption with no loads running is 2 W and the power consumption with all loads on, the power consumption is approximately 16 W. The main factor to the power consumption when loaded is if the DC motor is loaded (if the rotor is being held in place).

One of the main measurements that were to be completed was the wireless range of the Xbee. This was to test its reliability in a real world application, where the switching would need to be completed over several miles or more. From the testing that was complete, the switching could only be completed over the range of approximately 100 feet. The Xbee pro that was used has a range of 300' indoors, so we believe that the limiting factor for the range is the Xstick. This particular component had no datasheet, as the device is relatively new, so therefore the advertised range cannot be determined.

For the software portion, initially the team wanted to be certain that this brand new technology of Xstick would work with the recommended software X-CTU and successfully switch the desired MOSFETs in the circuit. One issue with the software was that the ability to perform switching and acquiring the line voltage did not work as desired. This was due to the addressing of the analog to digital conversion had to be only directed at the Xstick and was not transmitting the switching signals properly. This is a minor issue as multiple Xbee's would be ideal in a real world application and would be able to use one Xbee for switching modes, and another Xbee for acquiring the voltage on each line.

The final problem that the team ran into was with the LabVIEW program. When it was run continuously, the program accumulated a full memory with data from the read buffer. This problem could not be overcome in the manner of running the program continuously. However, if the program is stopped following each switching operation the program is able to clear any previous memory from earlier operations, and the values previously held by each individual ZigBee module is stored due to the Xbee unique feature of retaining its previous input. This feature worked out very well for solving this problem. When the program is stopped and restarted for multiple switching operations, the issue of losing previous inputs given to each desired Xbee is negligible therefore making this memory problem minor and almost non-existent.

Some of the functionality that could be added, time and money permitting, would be adding some external loads that could be used to power a device, such as a cell phone. Another item that could be added, if the computing power were available, would be automatic switching from labVIEW instead of having the user switch every time an outage is detected.

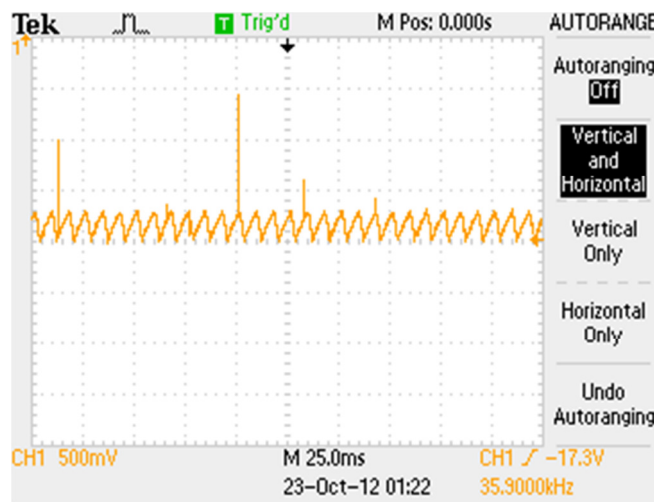

Fig. 5. Main line voltage ripple- grid connected

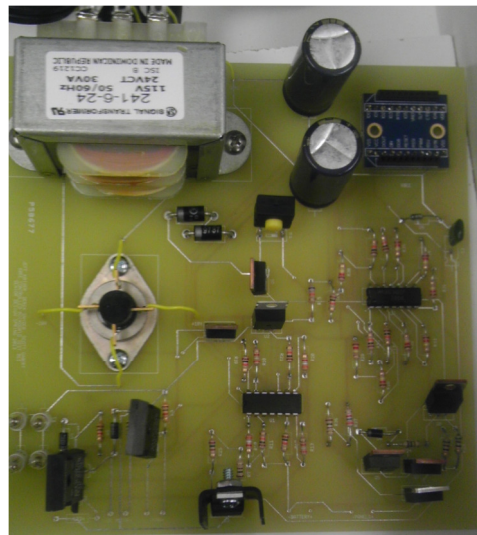

Fig. 6. Completed PCB (Fan, DC motor, and LED are not shown)

## VI. DISCUSSIONS & EDUCATIONAL OUTCOMES

For the most part, project objectives were met successfully. With the exception of the Labview interface and the Xbee issues that we faced, the design worked well. In order to implement this system on a full-scale design, a couple of changes would need to be made. First, with higher power AC distribution systems, relays would need to be used instead of MOSFETS. This is because MOSFETS cannot handle the voltage and current of modern distribution networks. The size and scope of this design did not permit for the use of relays, but a full scale design would need these components because of the high voltage.

Another consideration for future work, including larger scale implementation would be the range of the device. With only 100' of switching range, this would not be enough to complete the switching of a distribution network. This would be enough for a house though, especially if the range of the xstick were more. For a large-scale application, longer range Xbee modules would need to be used. Some of the modules can go over a mile, but even this may not be enough range. However, one of the features of Xbee is that those near each other can act as repeaters for a signal. Therefore, if Xbee's were close enough, an entire network could be designed over many miles so that the switching could be transmitted over a long distance. Some of the software considerations on a full scale use would include code for automatic switching as well as manual user switching from a single PC. For example, if the system detects a loss in power from the main line grid, it could automatically switch to batteries or solar panels while at the same time shutting off some of the loads. This would require some significant computing power though, as using a computer to control many Xbee's with a user interface is computationally intensive. Even in this project, a small scale implementation, some of the switching took a significant amount of time from when the user selected a change to when the actual voltage was outputted by the Xbee. This is because of the significant processing time the LabVIEW program takes until when XCTU sends the command. However, with some more processing power, a user interface with automatic switching could be implemented.

In summary, we have shown the implementation of a wireless control of a microgrid system. This could have many future applications, as the wireless controls are much cheaper and easier to implement than hard-wired solutions. This report highlights the work that has been done so far on the ZigBee controlled microgrid. The next steps in this project will be to finalize the circuitry design, but only after the software controls have been verified with the Xbee sensors using the XCTU software and LabVIEW. The group also hopes to test different types of ZigBee operating modes, including star and mesh modes. As the project progresses, parts of the above proposal may be changed as necessary.

### EDUCATIONAL OUTCOMES

This capstone project led to various educational outcomes and student gained the fundamental knowledge that are required to conduct this project through several junior and senior courses. The list is given in the following table.

<b>Courses</b>	<b>Concepts gained by students conduct the Senior Design Project</b>
EE 321 – Electronics I	321. Electronics I. 3 credits. Prerequisite: EE 313. Corequisite: EE 308. Fundamentals of semiconductors, nonlinear discrete components such as diodes and transistors, and integrated circuits; analysis and synthesis of simple electronic circuits, including amplifiers. F
EE 421 – Electronics II	421. Electronics II. 3 credits. Prerequisites: EE 314 and EE 321. Corequisite: EE 309. Analysis of electronic circuits and systems using

	discrete components and integrated circuits, digital circuits, active filters, and power amplifiers. S
EE 304 – Computer Aided Measurements and Controls	304. Computer Aided Measurement and Controls. 3 credits. Prerequisites: Math 165. The principles of the use of a computer in a measurement and control environment are presented. Software is designed to drive interfaces to perform measurement and control algorithms. The software and concepts presented are evaluated in a laboratory environment. F
EE 451 – Embedded Systems	451. Computer Hardware Organization. 3 credits. Prerequisites: EE 201 and 304 or consent of instructor. The study of complete computer systems including digital hardware interconnection and organization and various operation and control methods necessary for realizing digital computers and analog systems. On demand.
EE Electives	EE 421 and EE 423 Power System courses.

**Education Outcome 1:** Ability to communicate effectively, not only with engineers but also with the community at large In-depth technical competence in at least one engineering discipline. This is done via several written and oral presentations throughout the two semesters at UND.

**Educational Outcome 2:** Ability to undertake problem identification, formulation and solution. This outcome was accomplished by several refining process of design stages such as preliminary review design (PDR) and other successive weekly meetings with advisor.

**Educational Outcome 3:** Ability to utilize a systems approach to design and operational performance. For this project, there were several sub systems are integrated to achieve the overall objective of the system.

**Educational Outcome 4:** Ability to function effectively as an individual and in multidisciplinary and multi-cultural teams, with the capacity to be a leader or manager as well as an effective team member. The team involved in the project has contributed both at individual level and as a group. For example, Scott worked on LabVIEW interface, Derek worked on implementation of microgrid and Jeff worked on sensor integration aspects of the system.

**Educational Outcome 5:** Understanding of the social, cultural, global and environmental responsibilities of the professional engineer, and the need for sustainable development

**Educational Outcome 6:** Capacity for independent critical thought, rational inquiry and self-directed learning. The students involved in the project has made effort to research independently on various topics such as type of microprocessor used, sensor types, choosing an application software etc.

**Educational Outcome 7:** Intellectual curiosity and creativity, including understanding of the philosophical and methodological bases of research activity. The group looked and reviewed IEEE journals and conference papers on existing methods to carry out scholarly work and literature study.

**Educational Outcome 8:** Openness to new ideas and unconventional critiques of received wisdom. The student received constructive feedback from all our faculty and student groups during various stages of our presentations.

## VII. GROUP MEMBER CONTRIBUTIONS

Scott- Component and footprint selection, Circuit simulation/design, implementation and testing, troubleshooting, PCB Layout

Derek- DER testing, LabVIEW interface, implementation

Jeff- LabVIEW interface, ZigBee Programming, Breadboarding and testing

## VIII. CONCLUSION

A novel wireless switching mechanism using MOSFETS to control the micro grid is described in this paper. The preliminary results indicate that ZigBee wireless control in combination with MOSFET switching techniques enables a fast switching rate in the order of milliseconds. The future work is to test different types of operating modes, such as star and mesh topology on a large scale grid deployment.

## ACKNOWLEDGMENT

The authors would like to thank the department of Electrical Engineering at the University of North Dakota for funding the project and providing the equipment necessary for building and prototyping the design.

## REFERENCES

- [1] Robert Lashter, Micro grid: a conceptual solution, PESC'04 Aachen, Germany 20-25 June 2004. URL: <http://energy.lbl.gov/ea/certs/pdf/mg-pesc04.pdf>
- [2] H. Jiayi, J. Chuanwen, and X. Rong, "A review on distributed energy resources and microgrid," *Renewable Sustainable Energy Rev.*, vol. 12, no. 9, pp. 2472–2483, 2008.
- [3] C. Marnay and G. Venkataramanan, "Microgrids in the evolving electricity generation and delivery infrastructure," in *Proc. IEEE PES General Meet.*, Montreal, QC, Canada, Jun. 18–22, 2006.
- [4] "Xbee wireless RF Modules," [Online]. Available at <http://www.digi.com/xbee/>
- [5] Nikos Hatziargyriou, Hiroshi Asano, Reza Iravani, and Chris Marnay. "Microgrids". *IEEE Power and energy magazine*, July/August 2008.