



## Design, Development, and Testing of Load Cell Accelerometers

**Dr. Dale H. Litwhiler, Pennsylvania State University, Berks Campus**

Dale H. Litwhiler is an Associate Professor at Penn State, Berks Campus in Reading, PA. He received his B.S. from Penn State University, M.S. from Syracuse University, and Ph.D. from Lehigh University all in electrical engineering. Prior to beginning his academic career, he worked with IBM Federal Systems and Lockheed Martin Commercial Space Systems as a hardware and software design engineer.

# Design, Development, and Testing of Load Cell Accelerometers

## Abstract

As part of an instrumentation and measurement theory course for third-year Mechanical Engineering students, accelerometers were produced using a mini load cell beam (100 grams max) as the sensing element. The students worked in small teams to design, develop, and test a custom accelerometer with a measurement range of  $\pm 4$  g. Although using a load cell does not represent a practical approach to modern accelerometer design, it does provide a means for investigating many of the design considerations and concepts required to understand accelerometer operation. The students were given specifications for the accelerometer and made design tradeoffs and decisions to meet the requirements. Students were also required to develop and implement a test procedure to verify specification compliance. A modest budget was provided to allow the design teams to purchase materials. The campus machine shop is very well equipped and staffed and was available to help fabricate custom parts. 3-D printing of parts was also an option for the teams to use. An instrumentation amplifier circuit board kit was available for the students to integrate into their design. The project provided a very good means of unifying many aspects of the course. The fabrication experience gained through this project is also a valuable component of the mechanical engineering curriculum. This paper presents examples of student accelerometer designs and data from prototype testing. Equipment and methods used to test the prototypes are also presented and discussed.

## Introduction

The benefits to undergraduate engineering students of hands-on experience is well documented [1], [2]. If the hands-on experience is gained in the process of completing a team project, the benefits are even more valuable [3] – [5]. Although not all undergraduate engineering courses lend themselves to hands-on projects, some are especially suited for the task. The plethora of physical devices and systems discussed in instrumentation and measurement courses certainly provide basis for many suitable projects. The work presented here involves the design, development, and testing of an accelerometer by students in a third-year mechanical engineering instrumentation and measurement theory course.

Each year, a different type of measurement device is chosen as the focus of the project. Previous projects have included Pitot-static probes, capacitive fluid level probes, rotary encoders, and kitchen scales. Although the students are different each year and the same device could be used, the faculty continue to improve upon the experience and build a repertoire of projects that are used for demonstration of concepts in following years. This helps to show incoming students the range of possibilities for devices that could be produced with their level of experience rather than confining their thinking to one type of device.

The overall intent of the project is to demonstrate to the students how various topics discussed throughout the semester converge to produce the desired result. Depending on the device for the project, the order of topics discussed during the semester may be modified. It is important that enough of the baseline material has been covered to allow the students to make informed choices and tradeoffs in their design process. Obviously, the design must start well before the end of the semester so some material may need to be supplemented by the students on their own, as needed.

Students choose small teams, usually two or three members, to work on the project. The team members quickly determine the skills and deficiencies of the team which tends to guide many of the design decisions. The project usually involves some concepts that are outside of the comfort zone of all members. The teams are given a roughly outlined specification for the performance of the instrument to be produced. They are also given a small budget, preferred sources for parts, and list of milestones to help keep the projects moving. Table 1 shows a summary of the accelerometer requirements.

- Acceleration measurement range:  $\pm 4$  g ( $\pm 39.2$  m/s<sup>2</sup>)
- Maximum acceleration range:  $\pm 6$  g
- Zero-g offset:  $+2.5 \pm 0.125$  VDC
- Static sensitivity:  $+0.5 \pm 0.025$  V/g
- Maximum total weight: 180 grams
- Maximum outside dimensions: 2.25”L (active axis) x 1.75”W x 3.5”H
- Natural frequency: 50Hz – 200Hz
- Device operating power supply voltage:  $+5$  VDC  $\pm 0.1$  VDC
- Maximum power supply current: 15 mA
- Mounting hole pattern must match provided drawing

Table 1. Summary of accelerometer requirements

Students were encouraged, but not required, to use a small load cell beam as the main measurement transducer of the project. All teams did eventually use this type of load cell. By attaching a proof (seismic) mass to the load cell, a basic accelerometer could be realized. The size and material of the proof mass was an important design consideration. An instrumentation amplifier circuit board was provided for use by the teams. The gain required to achieve the specified instrument sensitivity was also a key part of the design process. The design of the instrument housing to meet the structural strength, dimensions, and mounting specifications was a large part of the effort, as well. Figure 1 shows a photograph of several of the team designs.

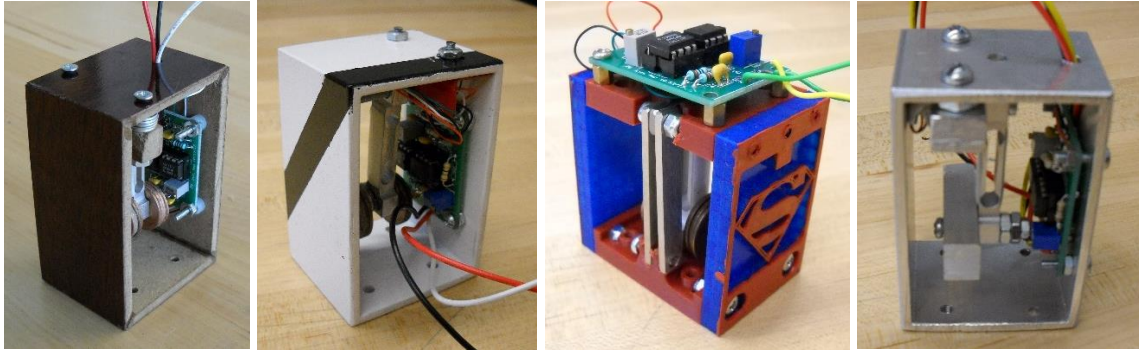

Figure 1. Photographs of several accelerometer designs

The accelerometers were tested in several ways to determine compliance with the specifications. The dimensions and weight of each device were measured. The accelerometers were calibrated (offset and gain adjustments performed) by subjecting them to 0 g and  $\pm 1$  g by simply tilting them at  $0^\circ$  and  $\pm 90^\circ$  angles with respect to horizontal using a digital carpenter's level as the reference. The accelerometers were placed on a centrifuge turntable to produce a range of accelerations from 0 g to 4 g in opposing directions along the active axis [6]. Finally, each unit was subjected to low-level sinusoidal vibration to determine its frequency response performance [7]. Data was collected and analyzed to determine requirement conformance.

### **Pertinent Course Topics**

The instrumentation and measurement theory course is typically taken by BSME students in the first semester of their third year. The course topics that were illustrated and emphasized by the accelerometer project include the following:

- Accelerometers
- Load cells
- Second-order response
  - Natural Frequency
  - Damping Ratio
  - Resonance
- Static sensitivity
- Instrumentation amplifiers
  - Gain Selection
- Dynamic Error
- Uncertainty Analysis
- Propagation of Uncertainty
- Strain Gauges
- Test Equipment Setup and Use

## Accelerometer Construction

The majority of the teams opted to follow the lead of the instructor's prototype by using a 100 gram load cell beam suspended inside a short piece of aluminum rectangular tubing. One team used wood as the housing material while another team produced a 3-D printed frame with an embedded "Superman" emblem. The proof mass was composed of various types, shapes, and sizes of metal.

The 100 gram load cells were purchased from an online vendor in sufficient quantity to provide a few spares [8]. Figure 2 shows a vendor-supplied dimensional photograph of the load cell. The vendor's datasheet information is shown in Table 2. The students were advised to carefully measure any critical parameters despite the values given by the vendor.

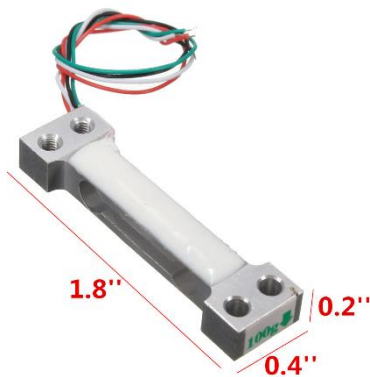

Figure 2. Load cell photo including outside dimensions

Range: 100 grams
Output Sensitivity: $1.0 \pm 0.15$ mV / V
Zero drift: 0.05 / 0.03% F.S (30 min)
Zero point temperature drift: 0.05 / 0.03% F.S / $10^\circ$
Zero output: $\pm 0.1$ mV / V
Input impedance: $1055 \pm 15$ $\Omega$
Output impedance: $1000 \pm 5$ $\Omega$
Overload capacity: 200% F.S
Recommended excitation voltage: 5-15V
Maximum excitation voltage: 15V

Table 2. Load cell specifications

An instrumentation amplifier circuit was used to scale and offset the differential output voltage of the load cell's strain gauge bridge. Figure 3 shows the schematic diagram of the amplifier circuit. The teams were provided with the amplifier printed circuit board and the components. Circuit board assembly, including soldering, was their responsibility. To determine the required instrumentation amplifier gain, a known mass (100 grams) was placed on the load cell while it was clamped horizontally to the edge of a lab bench. The load cell output voltage was measured with a DMM while the bridge was powered with 5.0VDC. Using this measurement together with the no-load value, the required gain (and thus the IA gain resistance) could be found.

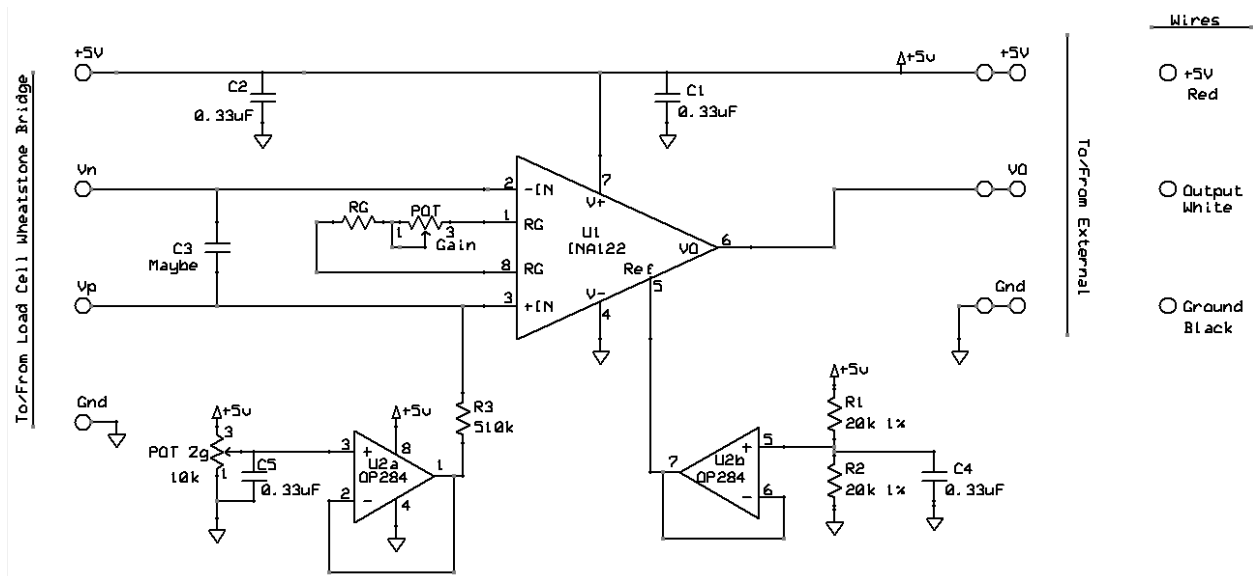

Figure 3. Instrumentation amplifier circuit schematic

### Calibration

The amplifier circuit provides the necessary adjustment capability to calibrate the load cell accelerometer. With no load applied (load cell in the vertical position) and an input power supply voltage of 5.0VDC, the zero-g offset was adjusted with “Zg” potentiometer. Zg was adjusted such that the output of the instrumentation amplifier, U1, was 2.5VDC. The load cell accelerometer was then placed in the horizontal position such that the output of U1 increased from its zero-g value. The “Gain” potentiometer was adjusted until the output of U1 was 3.0VDC. The assembly was then flipped such that the load cell experienced a 1g acceleration in the opposite direction to confirm that the output voltage of U1 now read near 2.0VDC. These calibration steps were repeated until the measurements were within the specified tolerance. An electronic carpenter’s level was used as the tilt angle reference as shown in Figure 4.

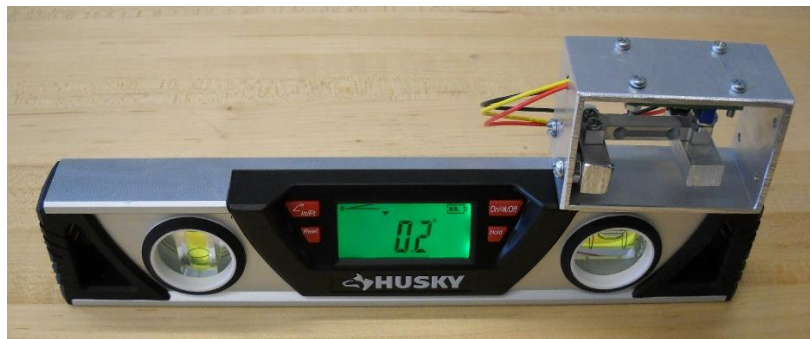

Figure 4. Accelerometer bench calibration setup

## Size and Weight Testing

Each team's accelerometer was measured to determine conformance to the size and weight specifications. Figure 5 shows the simple but effective methods for these tests.

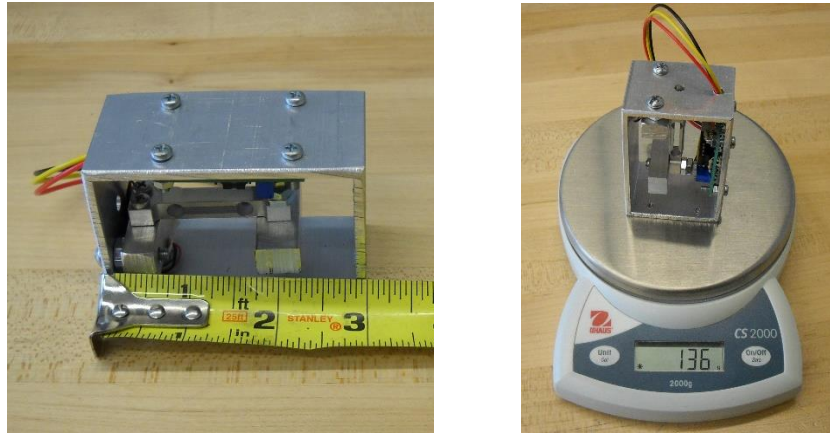

Figure 5 shows photos of size and weight testing.

## Centrifuge Turntable Testing

To exercise the full-scale range of the accelerometer designs, a custom centrifuge turntable was used. The accelerometers were subjected to constant centripetal acceleration by mounting them at a fixed radius (4 inches) on a horizontal turntable rotating at a constant angular speed. A reference accelerometer was mounted on the turntable at the same radius as the devices under test. Accelerometer outputs were measured by a battery-powered wireless data acquisition system mounted on the turntable. Power was provided to the accelerometers via batteries and a voltage regulator also mounted on the turntable. Data was collected on the receiving end of the wireless link and displayed using a custom LabVIEW VI. Figure 6 shows the centrifuge turntable setup. The centrifuge could accommodate testing of two accelerometers simultaneously to save time and to help balance the load on the turntable. Figure 7 shows the front panel user interface displaying data from both accelerometers under test and the reference device. Data obtained for two teams' accelerometers is shown in Figure 8.

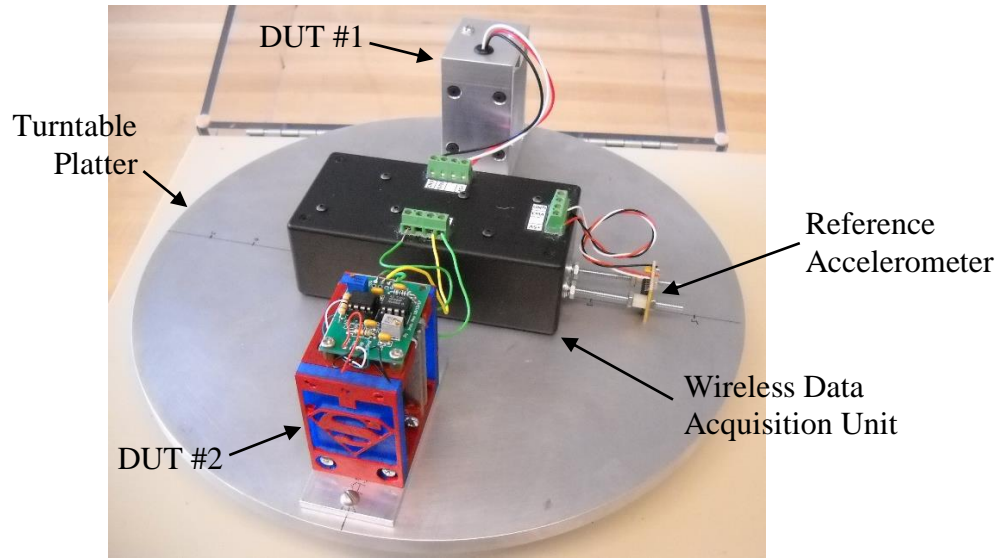

Figure 6. Centrifuge turntable setup for constant-acceleration testing

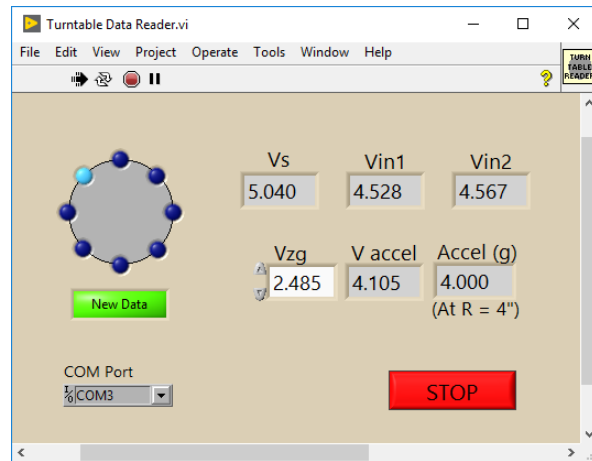

Figure 7. LabVIEW front panel of turntable data collection VI

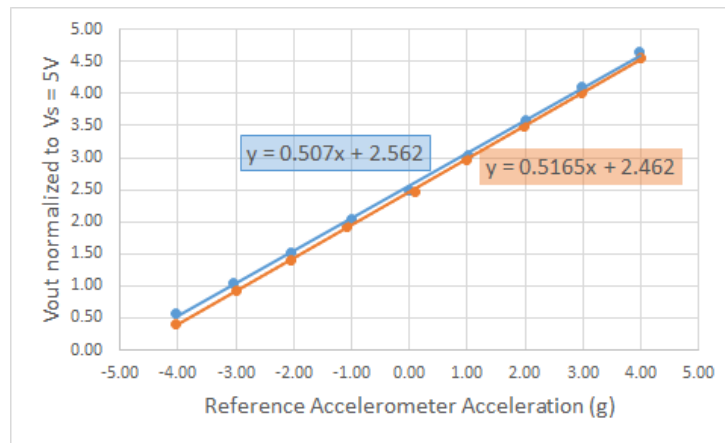

Figure 8. Plots of turntable test data for two teams' accelerometers



## Dynamic (Vibration) Testing

The accelerometers were subjected to swept-sinusoidal vibration testing to determine their natural frequency. As shown in Figure 9, each device was mounted to a modified subwoofer speaker which was driven by a function generator and power amplifier [7]. A reference accelerometer mounted to the vibrating assembly was used to determine the actual acceleration experienced by the device under test [9]. The function generator amplitude was adjusted to maintain small signal levels across the swept frequency range. Figure 10 shows an example plot of the frequency response of one team's accelerometer. Due to the nature of the components, the accelerometers were very underdamped and thus exhibited large resonant peaks.

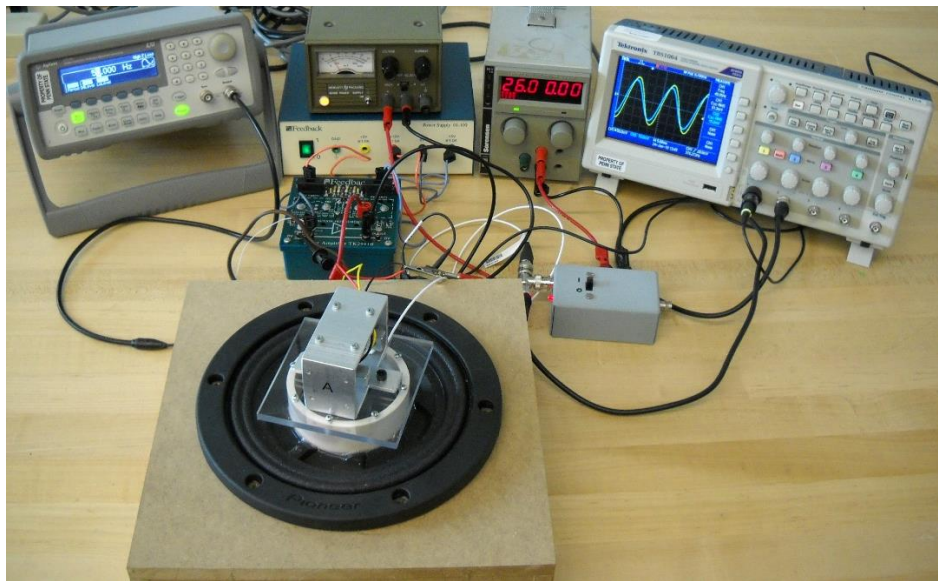

Figure 9. Subwoofer shaker test setup

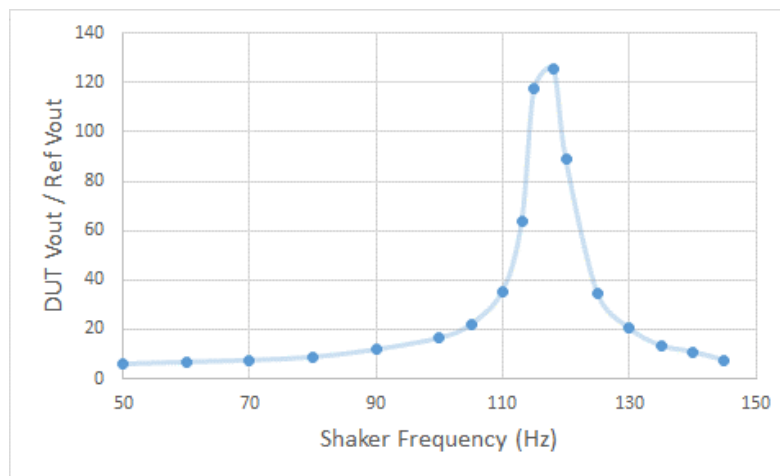

Figure 10. Load cell accelerometer frequency response example

Although the frequency response plot is interesting, the main parameter needed for this exercise was the natural frequency. To estimate the natural frequency of each accelerometer, the frequency of the function generator was adjusted while observing the output of the device under test and the reference accelerometer on an oscilloscope. As discussed in the course, at the natural frequency, the phase shift of a second-order system is  $90^\circ$ . This phase shift is fairly easily recognized from the oscilloscope traces. Figure 11 shows oscilloscope screen captures for one of the accelerometers excited with vibration frequencies below, at, and above the natural frequency, respectively. The natural frequencies of the student designs were found to range from 80 Hz to 130Hz. All of these values were within the specified range.

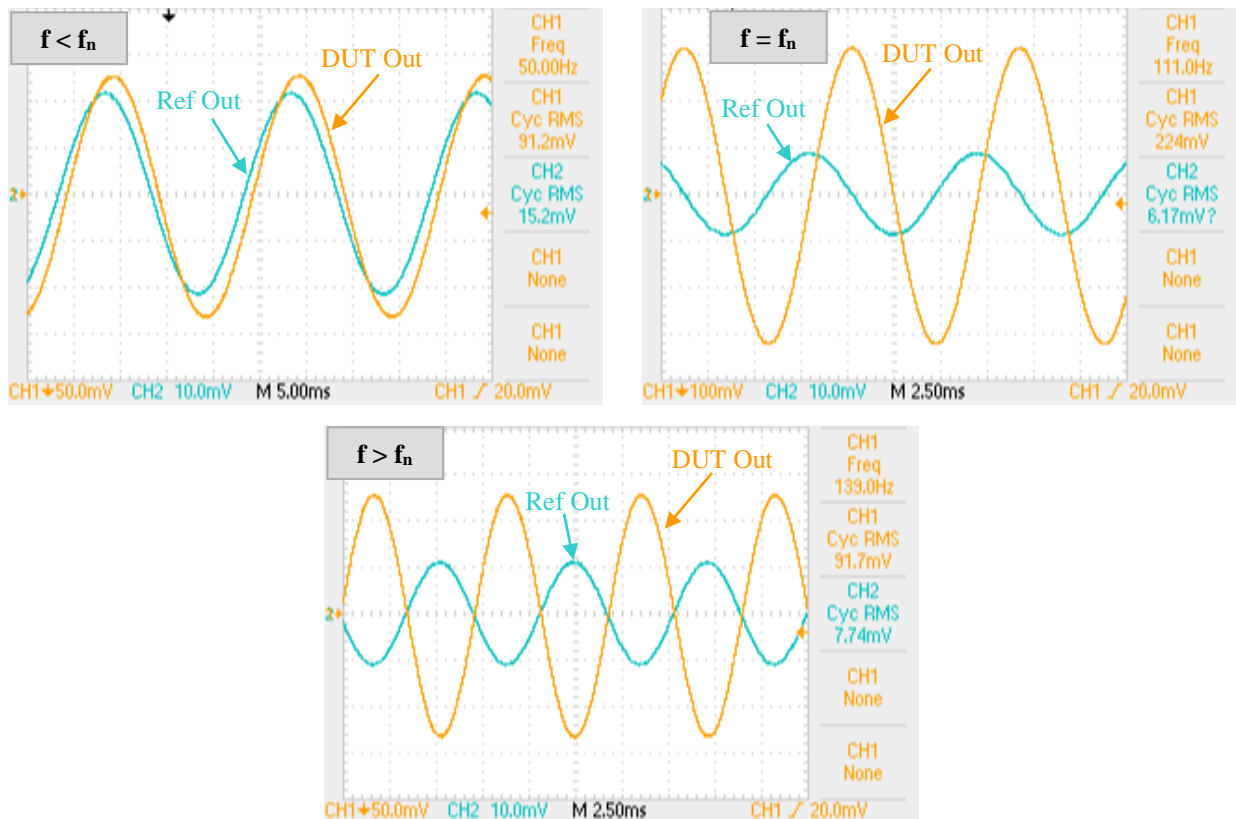

Figure 11. Oscilloscope data for a load-cell accelerometer excited below its natural frequency (top left), at its natural frequency (top right), and above its natural frequency.

## Conclusions

The accelerometer project provided the mechanical engineering students with hands-on experience that they had not previously encountered. For some students, it was the first time they had used a hand drill or soldering iron. The project also served to highlight many aspects of the course and show how these concepts can be combined to create an actual useful device.

To assess student learning from the project, a formal report from the students was required. Each team also had to demonstrate the performance of their prototype to the course instructor. The report included a device user's manual and a completed test procedure. The following guidance for the report was provided to the students:

**Project Report (One report per team. Due at the time of the final exam)**

The project report consists of two components:

- Device user's manual
  - The user's manual should describe the features, limitations, and operation of your device. Device specifications should also be included. Instructions for setup and use must be clearly shown. This document would be used by the final customer of your device.
- Test procedure **including test data for your prototype**. The test procedure should be written for use by skilled technicians at the manufacturing facility.
  - The test procedure should provide clear step – by – step instructions for test setup and data collection to fully test and calibrate your device.
  - The test procedure should be written such that the pertinent sections of the product specification are verified to be within the specified limits.

**Grading**

Demonstration	30%
Report	70%

The students were also polled after the completion of the project. The survey asked the students to rate how useful the project was in helping them to better understand the relevant course material. Of the 37 students involved with the project, 28 students participated in the survey. As shown in Figure 12, the majority felt that the project was useful to their understanding of course material.

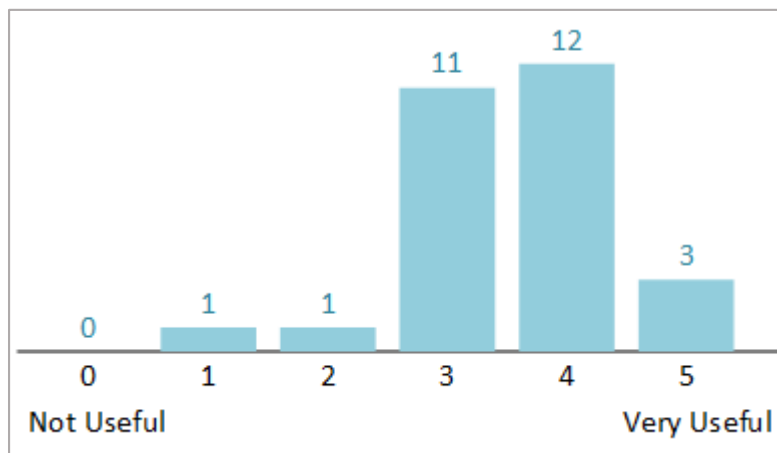

Figure 12. Histogram of student survey results.

The survey also asked students to indicate what aspects of the project were most and least interesting and useful to them. Some students indicated that working with tools and interfacing with the machine shop were very interesting and fun. The least interesting aspects included writing the test procedure and project report. Several students also felt that the schedule to perform the tasks of the project was too rushed. All of these comments will be taken into consideration for future projects.

At the beginning of the semester it was stressed that to receive full credit for the project, the team must produce a device that works at least at some level. This requirement was certainly a factor in some of the risk-taking decisions made by the teams. Although there were several technical difficulties encountered throughout the semester, by the final week of class, *all teams* had produced a working prototype. With a few small exceptions of the size and weight of some prototypes, each team was able to meet the requirements.

Although a 4g acceleration requirement is minimal, it still provided a level of gee-whiz to the project. Students were concerned about their design flying apart on the centrifuge which perhaps encouraged them to more carefully fasten and secure all components of their accelerometers. By working with the students in the laboratory, it was obvious that spinning and shaking something that they had designed and built, certainly added some excitement to the course.

## References

- [1] J. Keska, "Instrumentation Emphasis In Undergraduate Mechanical Engineering Programs," in *Proc. of the ASEE Annual Conference & Exposition, 2010, Louisville, KY, USA*, [Online], available <https://peer.asee.org/16249>. [Accessed Jan. 25, 2018].
- [2] P. Avitabile, "An Integrated Undergraduate Dynamic Systems Teaching Methodology Utilizing Analytical And Experimental Approaches," in *Proc. of the ASEE Annual Conference & Exposition, 2007, Honolulu, HI, USA*, [Online], available <https://peer.asee.org/2617>. [Accessed Jan. 25, 2018].
- [3] D. Aoyagi, "Pilot Implementation of a Task-based, Open-ended Laboratory Project using MEMS Accelerometers in a Measurements and Instrumentation Course," in *Proc. of the ASEE Annual Conference & Exposition, 2017, Columbus, OH, USA*, [Online], available <https://peer.asee.org/27797>. [Accessed Jan. 25, 2018].
- [4] D. Litwhiler, "A Two Semester, Multi-Approach Instrumentation Project for Mechanical Engineering Students," in *Proc. of the ASEE Annual Conference & Exposition, 2015*,

Seattle, WA, USA, [Online], available <https://peer.asee.org/23470>. [Accessed Jan. 25, 2018].

- [5] S. Kiefer, "Preparing Mechanical Engineering Students For Senior Design Projects With Electronics Components," in *Proc. of the ASEE Annual Conference & Exposition, 2007, Honolulu, HI, USA*, [Online], available <https://peer.asee.org/2873>. [Accessed Jan. 25, 2018].
- [6] D. Litwhiler, "Mems Accelerometer Investigation In An Undergraduate Engineering Technology Instrumentation Laboratory," in *Proc. of the ASEE Annual Conference & Exposition, 2010, Louisville, KY, USA*, [Online], available <https://peer.asee.org/16392>. [Accessed Jan. 25, 2018].
- [7] D. Litwhiler, "A Custom Vibration Test Fixture Using a Subwoofer," *International Journal of Modern Engineering*, vol. 11, no. 2, pp. 68-73, Spring/Summer 2011. [Online]. Available: [http://ijme.us/issues/spring2011/spring\\_2011.htm](http://ijme.us/issues/spring2011/spring_2011.htm). [Accessed Jan. 25, 2018].
- [8] Alex NLD catalog, [Online]. Available: <https://alexnld.com/product/100g-range-aluminum-alloy-small-scale-high-precision-weighing-sensor-load-cell/>. [Accessed Jan. 25, 2018].
- [9] PCB Piezotronics catalog, 333B30 accelerometer, [Online]. Available: [http://www.pcb.com/Products/model/333B30/item\\_id/9183](http://www.pcb.com/Products/model/333B30/item_id/9183). [Accessed Jan 25, 2018].