



Designing Communications and Power for an Instrumentation System for Natural Resources Research in a Remote Mountainous Location

Dr. Herbert L. Hess, University of Idaho, Moscow

Herb Hess is Professor of Electrical Engineering at the University of Idaho, where he teaches subjects in He received the PhD Degree from the University of Wisconsin-Madison in 1993. His research and teaching interests are in power electronics, electric machines and drives, electrical power systems, and analog/mixed signal electronics. He has taught senior capstone design since 1985 at several universities.

Designing Communications and Power for an Instrumentation System for Natural Resources Research in a Remote Mountainous Location

Abstract

To investigate important aspects of a mountainous ecosystem, a group of students designed and built an instrumentation array. The goal was to monitor effects of climate change. The pristine environment provided a unique and valuable place for establishing a baseline of data. In all, 78 sensors were divided into three wired micro-networks at altitudes of 1200m, 1800m, and 2400m. Among these sensors were CO₂ sensors, precipitation, temperature, soil moisture, leaf wetness, animal traffic, etc.

Important challenges for power and communication included three-dimensional terrain, forest canopy, and creative sensor placement. The three networks were linked wirelessly to each other and to an Internet router to storage and presentation two thousand kilometers distant. The networks provided communications through self-healing mesh topologies. Experience soon showed that the current state of technology is not as well developed as one might expect for reliable communications in this challenging environment. Power was available from combinations of wind, photovoltaic, and hydroelectric sources with lithium battery storage. Providing small amounts of power in the remote location with solely renewable sources encountered proved to be quite difficult. To maintain the pristine nature of the environment and test conditions, power apparatus had to be carefully placed and concealed.

This paper describes the design and installation of this instrumentation system in the remote mountainous environment. Two years after installation was completed, student learning is assessed by improvements quality of data collection over the course of the project and by the quality of data presented since the project.

Introduction

The Mountainous Ecosystem Sensor Array (MESA) project is a wireless 3-D environmental sensing network designed for climate change research located near Taylor Ranch in the Frank Church River of No Return Wilderness Area in the State of Idaho. The MESA system has a total of 78 sensors in three identical arrays called micro-nets. The main purpose of the project is to monitor a mountainous ecosystem in three dimensions. To achieve this, the micro-nets are spatially distributed from top to bottom on the mountain, and from the top to the bottom of 25 meter trees. This identifies the ecosystem by major elevation and by layers of forest canopy.

The project goals are as follows:¹

- 1) To achieve real time wireless three dimensional monitoring of a mountainous ecosystem.
- 2) To comply with all the minimum impact requirements in the Wilderness Act of 1964.
- 3) To make the system autonomous, requiring maintenance at most once per year.

- 4) To physically install the system and have it functioning within one year.
- 5) To maintain sensors within industry standard tolerances.
- 6) To receive all data generated by all sensors with minimal interruptions.
- 7) To develop a system to manage and store the data generated by the sensors.

Design of the instrument array

This project's challenge is to design an autonomous mesh network to collect complex climate data in a remote wilderness area, the Frank Church – River of No Return Wilderness Area located in south central Idaho. Together with the adjacent wilderness and roadless areas of national forest, this area comprises the largest and most remote wilderness location in the continental United States. Most current environmental data and models for such ecosystems are nonexistent due to the need for frequency visitation and the high cost of access. This network serves as an unprecedented 3D visualization of ecosystem processes within remote mountainous regions of North America. A concurrent challenge is to design the network with minimal or no impact upon the wilderness ecosystem.¹

The network design consists of three micro-networks spanning 2km of horizontal distance and over 600m of elevation change. The upper site is 1830m above Mean Sea Level. The mid site elevation is 1544m and the lower elevation is 1170m. The two upper sites are in the Wilderness Area and have a five-year permit to operate. The lower site is on a university research station and may remain in place indefinitely. Figure 1 illustrates the site and its terrain. The nearest paved road is 80km to the west. The nearest connection to the electrical power grid is 65km to the east. Access is by small plane at the grass airstrip just outside the left edge of the photo in Figure 1, by small boat on the river behind the lower treeline, or by mule on the trail over the surrounding mountains.

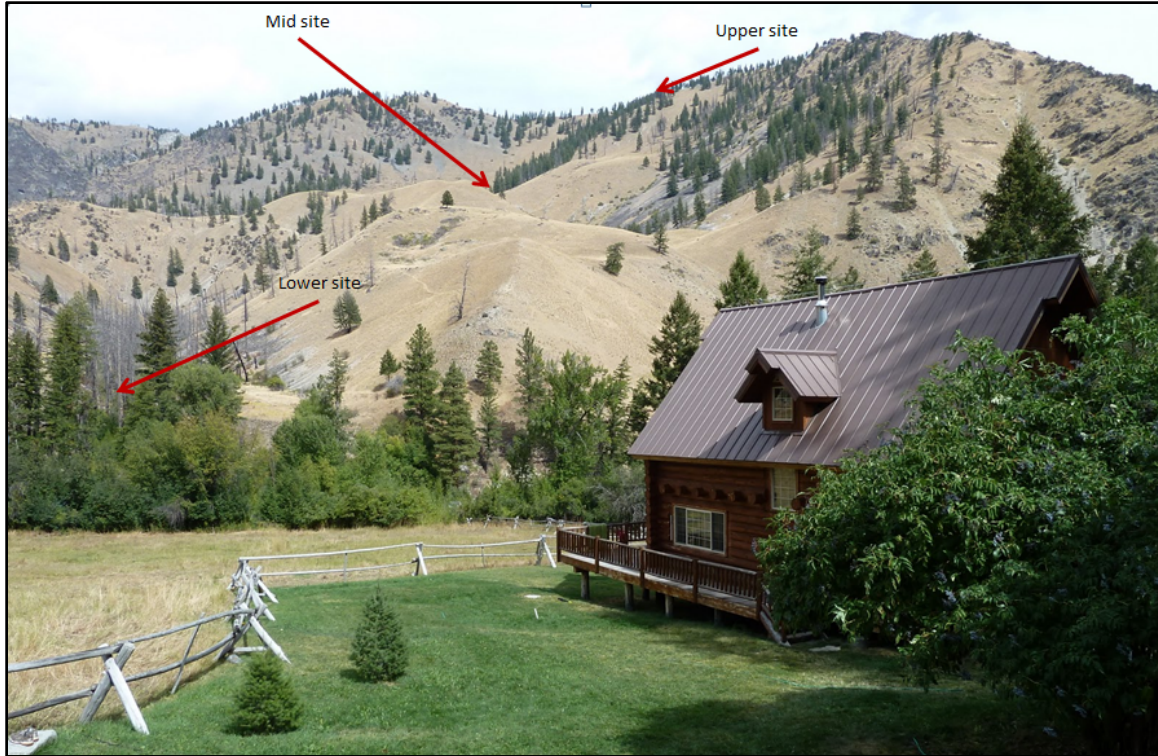

Figure 1. Wilderness site of installed instrumentation system²

The instrumentation system consists of three micro-networks each containing 26 sensors and ten network devices. Sensors and devices are mounted on one of four trees illustrated in Figure 2. The other three trees had similar configurations.

Sensor	Sensor #	Sample rate
CO2*	1	2 min
temp/humidity	2	2 min
soil moisture/Temp*	3	30 min
2-way radiometer*	5a	2 min
4-way radiometer*	5b	2 min
snow depth	6	2 hr
WXT520*	7	2 min
Dendrometer	8	1 hr
leaf wetness	9	2 min
Intelemote	10	
Inteleccl	11	

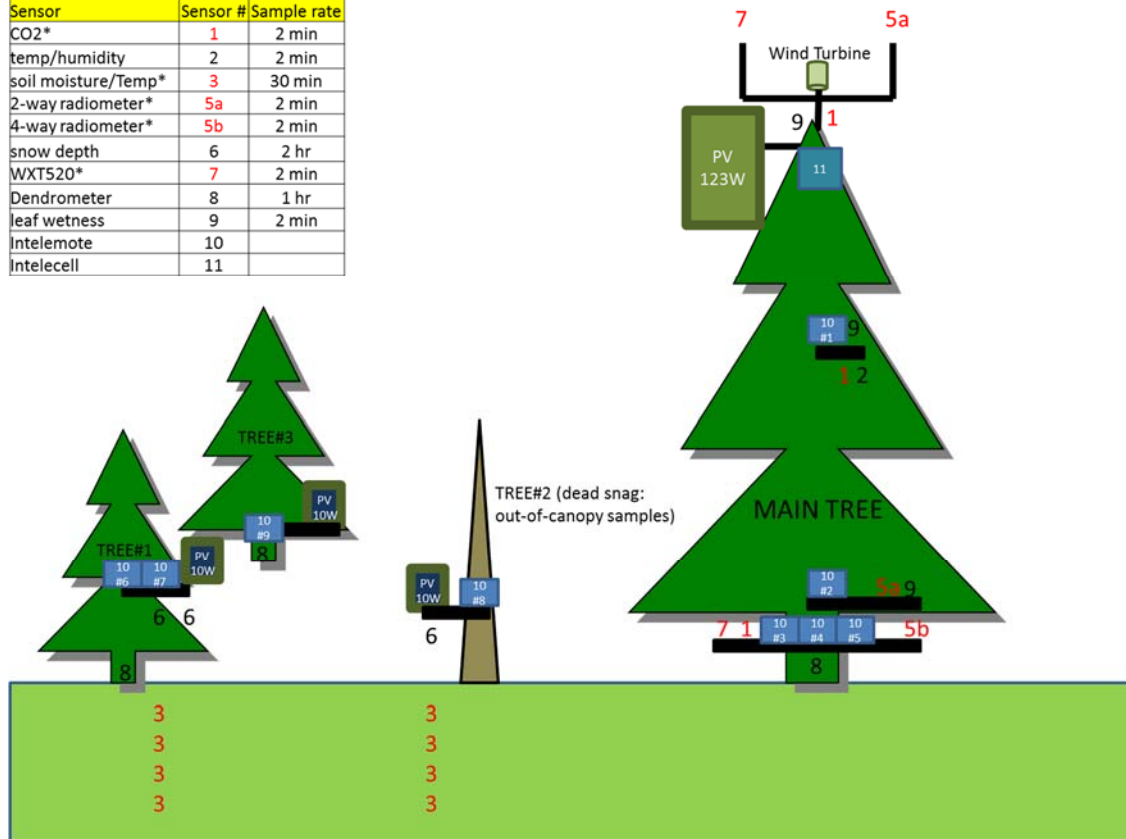

Figure 2. Sensor and energy locations on main tree³

The instrumentation array contains the following sensors:³

- Carbon dioxide: Vaisala GMP343 sensor measures infrared light absorption in ambient carbon dioxide across a known path. Samples every two minutes are reported in parts per million onto an RS-232 interface.
- Temperature and humidity: Vaisala HMP155 has a platinum resistive temperature detector (RTD). It measures humidity by sensing capacitance variations of a thin film polymer capacitor. Its 0-1V analog output is reported every two minutes.
- Soil moisture and temperature: Steven's Hydra Probe senses variations in capacitance of a thin film polymer capacitor. Probes are installed at each of three prescribed depths. Each probe has an RTD probe for soil temperature. Data is reported at 1200 baud on a Serial Data Interface (SDI). A Vegetronix SDI to RS-232 translator prepares data for storage and transmission.
- Solar radiation: Hukseflux RA01 and NR01 use pyranometers to sense short wave radiation (300nm to 2800nm) and long wave radiation (4500nm to 50000nm). Neither model requires an external power supply. ADS1115 differential voltage amplifier provides an analog 0-3V output. EME Systems OWL3Pro board translates the data to a digital stream onto an RS-232 bus.
- Snow depth: Judd Communication Depth Sensor measures snow depth by timing a 50kHz ultrasonic pulse reflected from beneath the snow surface. It has an RTD sensor to calibrate for temperature variations in the speed of sound.

- Weather Station: Vaisala WXT 520 Weather Transmitter measures wind speed and direction (ultrasonic anemometer), precipitation (piezoelectric sensor to count individual raindrops; uses statistical algorithms to calibrate for frequency and intensity of droplet impacts), atmospheric pressure (silicon capacitor), temperature (ceramic capacitor), and relative humidity (polymer capacitor). Data is reported as a serial bit stream onto an RS-232 bus.
- Dendrometer Instrument Sensor DR-26 measures tree trunk circumference using a thin stainless steel band that stretches a set of resistors. A bridge resistance sensor reports data as an analog voltage.
- Decagon Device Dielectric Leaf Wetness Sensor has a simulated leaf covered with small conductors that act as capacitors. Moisture changes affect the dielectric constant. Output is a 0.32-1.0V analog voltage.

All sensors were tested and calibrated under simulated conditions on the university campus. They were then moved to a wilderness site about 10 km from the university to be broken in before being transported and installed at the test site.

Mesh Network

Data obtained from sensors propagates through a mesh network to a gateway device connected to a satellite Internet link at the university research station. A server located at Intelesense Technologies in Fremont, California, collects and stores the data and presents it for analysis.⁴

A depiction of the instrumentation network is shown in Figure 3 with a simplified zoom of one micro-network. The instrumentation network can be understood as three micro-networks that are then connected to each other through an Intelecell controller. Three Intelecell controllers are interfaced to the Internet through a Gateway. Each micro-network consists of nine motes and one Intelecell powering and sampling the various sensors. Dotted lines represent a micro-network and solid lines represent the Intelecell network. Various network topologies were considered before settling on this interconnected mesh network. This offered the best combination of reliability and hierarchical control and data collection.

Any mote can act as router to propagate data packets to the Intelecell. In an outdoor location in a remote wilderness area, not all of the paths in the mesh are necessarily available all the time. Availability depends on several factors, most important of these are distance, weather, and obstructions. Each mote is programmed to seek its respective Intelecell, either directly or, failing this, through contact with other motes or another Intelecell. If devices temporarily lose contact with the network, the network recalculates a new formulation to maintain continuity. Even losing an Intelecell does not terminate communication because motes can join a neighboring micro-network. This availability of multiple paths leads to enhanced reliability of the mesh network. The network tends to be self-healing.

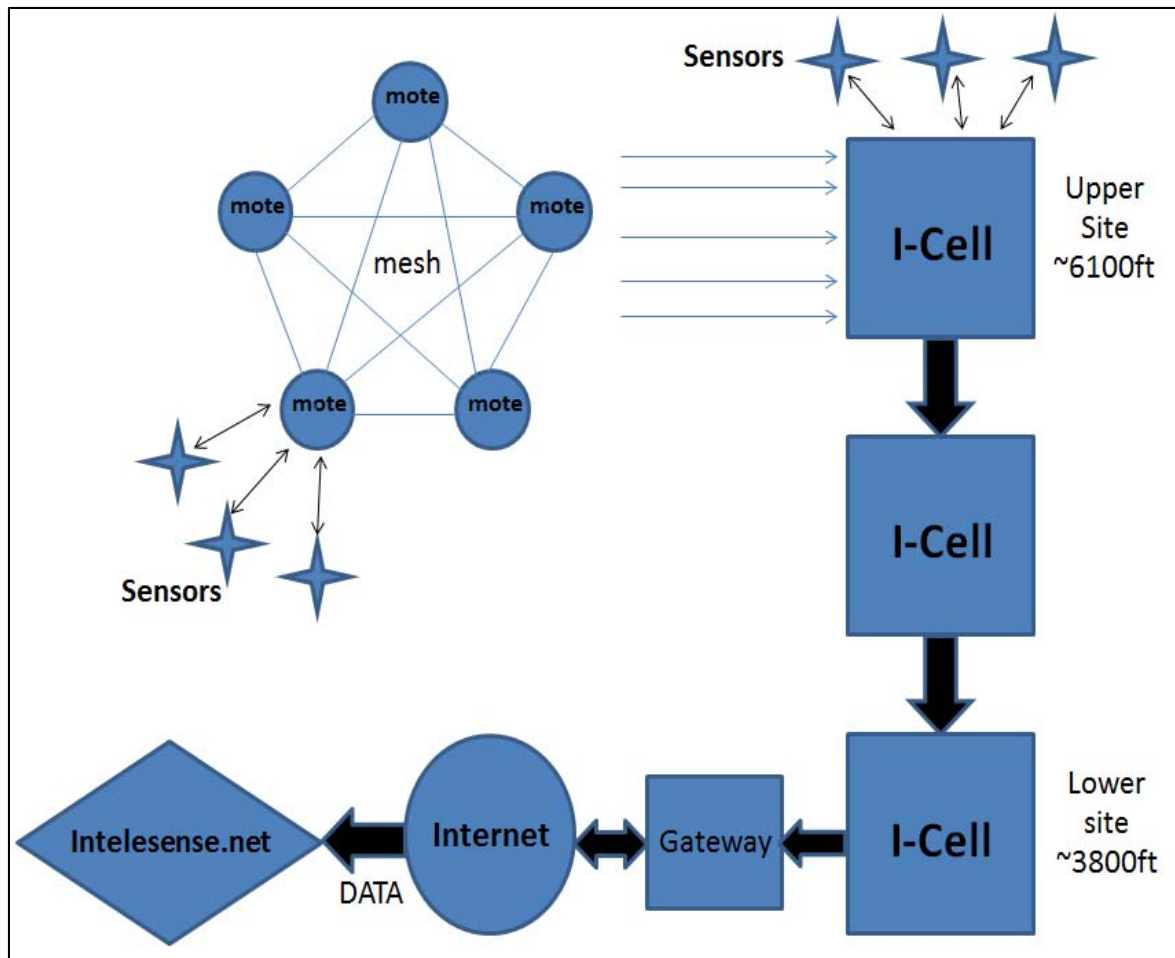

Figure 3. Mesh network system⁵

Data collection frequency is set manually. Data packets can backlog due to loss of power or Internet access or the loss of key nodes in the network. Experimentally, the collection interval to the Internet is set to fifteen minutes. Each mote has a wake time of 30-60 seconds, sufficient for it to collect data from its sensors and to send that data to its Intelecell even in bad weather. Based on reliability estimates, these settings, obtained through manually pushing the limits of the system over a period of several months, appear to be optimized for the network at hand.

XBeePro and XTend radios, components of the motes and the Intelecells, respectively, were appropriate for wireless communication within this instrumentation system. Radio range, approximately two km, can easily link the motes that are separated by less than 50m within a site. Sites are less than two km apart.

After the data has been collected and placed on the wireless data acquisition system of the motes and Intelesense modules, it is forwarded through an Intelesense Gateway to the university's Internet router on the research site. From there, it is routed to a server in Fremont, California, for display. Intelesense provides near real time display of data as it arrives.⁴

The entry page to the Intelesense display webpage is shown in Figure 4. <https://intelesense.net/data>⁴



Figure 4. Indexing webpage for this project.⁴

An example of the website that displays the data is shown in Figure 5. Shown here is the charging rates for five days in January (in brown) and the charge status of an energy storage battery (in red). The lower, smaller plot gives context. This data can be readily downloaded in graphical or tabular form by anyone with a web browser who creates an account.

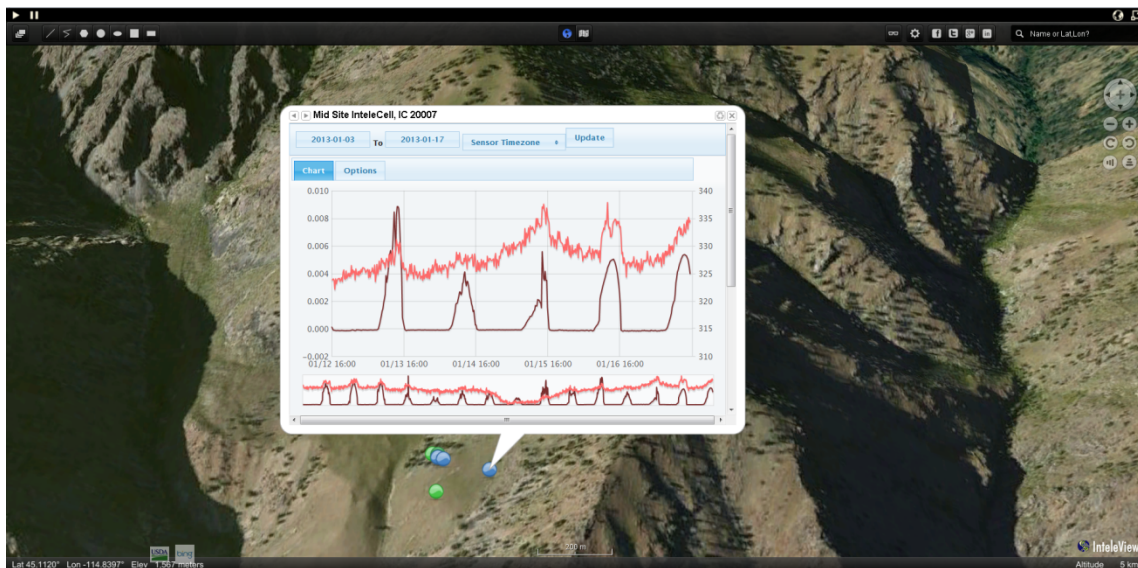

Figure 5. Webpage displaying the data.⁴

Throughout the design and installation of this communication network, technology evolved quickly. At the beginning of the project, the initial equipment was marginally reliable, leading to a great deal of frustration. Installation at the wilderness site near the university identified a host of problems in network reliability. Environmental factors, such as temperature and moisture, led to failure of radios and electronics. However, as each problem was identified, a solution came quickly from the manufacturer of Intelesense devices. The system, as it was finally installed and debugged, performed with remarkable reliability. The network as installed is autonomous, requiring no regular maintenance. It is nearly invisible to an on-site observer. In the end, 78 sensors at three different sites measured and reported over 200 environmental variables to anyone willing to read them on the Internet in near real time.

Power

The sensor and communications network requires electrical power. Based on the sum measured values from each sensor in operation, the main tree requires 13.1 Ampere-hours of current on a 12 Volt bus. The three peripheral trees require a total of 1.7 Ampere-hours each at 3.3 Volts. The nearest available connection to the public utility grid is 65 km to the east. Connection is prohibitively expensive. Renewable energy resources on site must be tapped to power the network.³

The site has abundant hydroelectric energy at the river and on the three creeks that run through the university property. Two years before this project began, the university's electrical system on site was upgraded to a 4.5kW capacity. Of this, 1.5kW is hydroelectric and 3kW is solar photovoltaic. There is a propane generator for backup, but other than being run for periodic maintenance, it has not been used. The university's power serves nine buildings, including living quarters and laboratories. Energy storage in lead acid batteries provides ride-through for five consecutive cloudy days, an event too rare to show on the site's weather records dating back to 1910. Careful power management provides reliable electrical power to a strongly summer-peaking load consisting of electronics and housekeeping for university researchers and caretakers.⁶

Electrical power from the university research facility is located closely enough to power the lower site through a 100-meter long line that crosses the river. The other two sites are too far away in the protected Wilderness Area to connect to the facility's power. Considering the environmental and safety problems with crossing a fast-flowing (>3 meters/second), debris-ridden river, a decision was made to power each side internally.

The sites have renewable energy in the form of solar, wind, and water. There is an abundance of biomass and the region is known to have abundant geothermal resources. Only the lowest site has water resources. Obtaining water rights to these resources is notoriously difficult and expensive. Tapping the biomass or the geothermal resources distorts the pristine character of the site, a character that underlies the main reason for the project. On the other hand, all three sites are on the south face of a mountain ridge, receiving abundant solar radiation year-round. Even the lowest site is just high enough up the canyon to get a full day's sunshine year-round. Wind energy is available in sufficient amounts to justify a wind turbine only at the uppermost site. To

eliminate cables between trees, each tree must be energy self sufficient, even the smallest systems in the smallest trees. Therefore, solar energy was selected as the primary resource because it is most available and has appropriately small impact on the sensitive location.^{3,5}

Determining how much solar energy is the next challenge. Irradiance maps from the National Renewable Energy Laboratory proved to be overly optimistic. Minimum seasonal solar radiation equates to about 1050 Watt hours per square meter per day. If system generation falls below this level on any day, energy storage would tend to become depleted and the system would fail. Solar energy is available an average of at least eight hours a day at this latitude. Any generation must be able to replace energy from storage each night as well as power the sensors directly during the day. Silicon solar panels have an efficiency of approximately 13% at the location and radiation levels at hand. A tilt of 26 degrees is optimum for the latitude of 45 degrees north. In this location, solar panels must be camouflaged or hidden, a requirement that tends to oppose the notion that they must face the sky unobstructed as much as possible.

Charge controllers are selected from among those recommended as most appropriate for the panels at hand. Solar Converters Inc (SCI) has a charge controller that fits the 3.3 Volt lithium ion batteries well. The same company's PT 12-5 B3.3 fits the 3.3 Volt lithium iron phosphate cells best, delivering five Amperes in a Maximum Power Point Tracking (MPPT) algorithm. The SCI PT 12-15, a MPPT charger, proved most effective for the lead acid batteries. All three chargers deliver a temperature compensated charging voltage set point.

For the smaller trees, a Solar Tech ten-Watt solar panel is sufficient, abundantly providing the load of 33 Watt hours each day and appropriate storage. Their flat black frame is easy to conceal up in a tree. For the main tree of the lower two sites, a 124 Watt Global Solar tactical solar panel meets the energy generation requirement. Its frame nearly matched the color and albedo of rocks and soil, so it is set up on the surface of the ground, as shown in Figure 6. For the upper site, a Warner Energy Star123 panel was selected due to its smaller size, greater efficiency, and its ability to hang conveniently concealed in a tree.



Figure 6. Concealed solar panels at the lower site.

Wind Power

Only the uppermost site has sufficient wind power to justify its use. The uppermost site has strong diurnal up and down drafts. Frontal weather enhances these winds from time to time but not often enough to be considered predictable. The lower two sites, being down in a canyon that is nearly perpendicular to the prevailing wind direction, do not experience sufficient wind. The solar generation system provides sufficient power for the instrumentation, but one wind turbine was desired to provide energy diversity and a test bed for future energy projects.³

Only a small wind turbine was desired. A dozen of these were evaluated. For wind turbines that realistically provide only a few hundred Watts, there is no widely recognized standard for comparing performance. Hence, claims tend to be overstated and difficult to verify before purchasing. Despite this, a good reference for shopping for small wind turbines is <http://allsmallwindturbines.com>⁷, a website that posts data on hundreds of turbines rated below 100kW. In the case at hand, a turbine with one meter of rotor sweep captures a fraction of the available 481 Watts at a wind speed of 10 meters per second. Most wind turbines in this size have efficiencies under 20%. Various topologies, such as horizontal axis (the most well know topology), shrouded, and vertical axis turbines are available in this size range. Other variables of interest include cost and cut-in speed. Cost is easy to quantify, but may not correlate to performance. Cut-in speed can be misleading because the turbine may turn, but it does not necessarily produce useful power at a low cut-in speed.

To narrow the search, turbines were sought from reputable local dealers. In the location at hand, these dealers were well known. That eliminated many possible turbines. Others were eliminated from consistently negative reviews on reputable websites. Horizontal axis turbines were

discouraged by the prospect of mounting them in a tree. Only with great difficulty could they be raised through the branches of a tree and, even at that, they must extend their full blade radius and more above the tree. This had mechanical concerns because any wind turbine in the location at hand must be placed upon a mount secured to the tree in a manner that does not damage the tree. Bending forces in high winds combined with long moment arms necessary to mount a horizontal axis turbine atop a tree gave an advantage to vertical axis turbines. The team selected a Forgen500 vertical axis turbine. Its seven kilogram weight, its nearly silent operation, and its short mount were attractive. It can be coupled directly to a battery bank without a charge controller. Its output at a “moderate breeze” of 6-8 meters per second matched the power requirements of the main tree. In the location at hand, winds average about four meters per second, but tend to be stronger on cloudy days. Placement is shown in Figure 7.



Figure 7. Installing the wind turbine.

A hybrid combination of solar power as primary and wind power as secondary adds reliability to the power supply. Figure 8 illustrates a hybrid design for the uppermost site. Each resource can power the system alone. For the other two sites, the same configuration, less the wind turbine, is an accurate representation. The negative correlation between wind and sunshine helps allocate energy generation naturally. This 12V generation system reliably powers the instrumentation system, its communications, and charges the energy storage batteries.

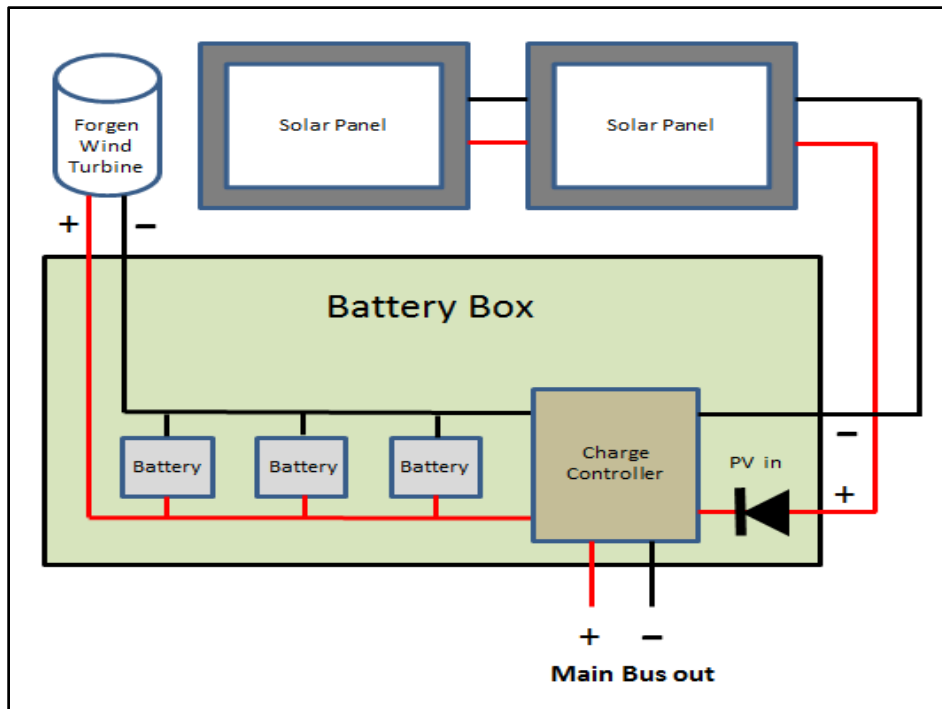

Figure 8. Energy design for the uppermost site.

Energy Storage

Energy storage is essential to any renewable energy system. In this situation, each of the three locations had identical energy storage needs. Studying weather records led to a conclusion that five days' energy storage is necessary for reliable power to the sensors. Energy storage would be in the form of batteries.

Several battery chemistries and manufacturers were considered. Options included lead acid batteries (flooded, gel, or absorbed glass mat), lithium batteries (cobalt, manganese, or iron phosphate), and nickel batteries (cadmium or metal hydride). Performance indicators were considered, including specific energy density, cycle life, temperature, maintenance, and safety. The most appropriate battery chemistry must be compatible with charging systems powered by the renewable energy sources. The applications at hand were included in the evaluation and the need for minimal attention required to guarantee clean environmental data. The candidates varied widely in cost. The decision on which battery to use was twofold. For the smaller daily 1.7 Ampere hours at 3.3 Volts at the peripheral trees, small packs of four parallel A123 Systems 26650 Lithium Iron Phosphate cells were considered best. For the larger daily 13.1 Ampere hours at 12 Volts at the main tree, East Penn Manufacturing Company's Deka AGM batteries were found to be best suited. Five days' supply at a 60% drawdown was deemed sufficient.³

Assessment

This project was performed by students from beginning to end. Two students were hired on a grant from the National Science Foundation (NSF) Major University Research Instrumentation

(MRI) Program. NSF considered the instrumentation system to be a major research instrument.¹ Indeed it was.

Students performed the design. They visited the site, trekked the mountain, assessed the resources and terrain, and created an instrumentation system for the site. They selected the instruments. They analyzed the energy resources, choosing a creative and useful combination of solar and wind. They selected the batteries. They integrated the Intelesense system. They programmed the data storage and display. They installed the system, organizing an airlift of 20 sorties to deliver the equipment to the site. They even drove the mules that carried the equipment up the mountain.

Two years after installation was completed, student learning is assessed by the quality of reports and improvements quality of data over the course of the project. Reports are readily available on the project website, as described above. The system performs as designed: data acquisition, communications, power, and even camouflage.

Sensor technology improved in part due to student efforts. This was a de facto beta site for the instrument manufacturer. Initial prototypes of the motes and modules were less than reliable. When they failed, the students shipped the equipment back to the manufacturer. Forensic analysis proceeded quickly and redesigned products were sent to the site, often within a few days. The quality of the instruments improved greatly within the eighteen months following initial installation.

The two students were likewise successful. One student went to a teaching and research assignment at the United States Air Force Academy. The other student proceeded to doctoral study. Data gathering from the site led to successful investigations for those skilled at research in natural resources at the university. The website provides its unique data to researchers worldwide.

Conclusions

This paper describes a project to create an instrument that acquires data on wilderness ecosystems. The project was student-led, from initial design through installation and use by natural resources researchers. Sensors to acquire the information were selected and are listed in the paper. Data was acquired and communicated through a highly robust communications network composed of two layers of a resilient mesh topology. Data is displayed on a server available to the public as specified in the project's charter. The system continues to provide reliable data of a unique ecosystem. Sensor technology advanced significantly due to the students' efforts in coordination with an instrument manufacturer. The students went on to teaching, research, and doctoral studies.

References

¹ K. Kavanagh, et. al., "MRI: Development of a smart 3-D wireless sensor network for terrain-climate research in remote mountainous environments," University of Idaho, ID, MRI NSF proposal 10-529, Apr. 21, 2010.

² University of Idaho publicity photograph.

³ D. Neal, "Design Considerations of Environmental Sensing Networks in Remote Locations," Masters Thesis, University of Idaho, January 2013.

⁴ Intelesense Corporation, Fremont, California, "Intelesense Technologies: University of Idaho MESA Project," <https://intelesense.net/data>. Accessed January 31, 2016.

⁵ D. Frome, "Powering Mesh Networks for Environmental Sensing in Remote Areas," Masters Thesis, University of Idaho, March 2013.

⁶ Hess, H., and J. Schlee, "Upgrade of a Successful Undergraduate Energy Project in a Remote Wilderness Location," 2010 ASEE Annual Conference and Exposition.

⁷ "All Small Wind Turbines, Portal to the World of Small Wind Turbines," Allsmallwindturbines, Waterland, The Netherlands, <http://turbines.allsmallwindturbines.com/>, Accessed January 31, 2016.

⁸ Neal, D., D. Frome, P. Robinson, K. Kavanagh, and H. Hess, "Integrated Energy Storage and Generation in Support of Very Isolated Data Collection," Power Sources Conference," Orlando, Florida, June 9-12, 2014.

⁹ Kavanagh, K., P. Gessler, A. Smith, B. Newingham, A. Davis, T. Link, Z. Holden, and H. Hess, "Development of a Smart 3-D Wireless Sensor Network for Terrain-Climate Research in Remote Mountainous Environments," American Geophysical Union Fall Meeting, San Francisco, California, 5-9 December 2011.