

## **2006-1324: DEVELOPMENT OF A COMPREHENSIVE INDUSTRIAL CONTROLS COURSE IN A MANUFACTURING ENGINEERING PROGRAM**

### **Arif Sirinterlikci, Robert Morris University**

Arif Sirinterlikci is currently an Associate Professor of Manufacturing Engineering at Robert Morris University. He has also served on the faculty of Texas Tech and Ohio Northern Universities. He holds BS and MS degrees, both in Mechanical Engineering from Istanbul Technical University in Turkey, and a Ph.D. in Industrial and Systems Engineering from the Ohio State University. His interests lie in various fields of Mechanical, Industrial, and Manufacturing Engineering.

# Development of a Comprehensive Industrial Controls Course in a Manufacturing Engineering Program

## Background

This paper illustrates efforts and their outcomes for re-design of an industrial controls course. The course, Device Control, has been taught in this ABET accredited undergraduate manufacturing engineering program since the inception of the program not so long ago. The course has been mainly taught as a PLC (Programmable Logic Controller) based controls course with a major experiential learning component including project-based laboratories for design of automated machinery. Students have been well exposed to PLC's and PLC-based control applications.

The course was recently modified by the author who is the new instructor. During the planning stage, the author studied the existing literature <sup>1,2,3,4,5,6</sup> and came up with his concept. His initial objective was to present a variety of different control technologies as options to prospective manufacturing engineers without contradicting the current course description and the objectives as presented below in Table 1

<b>Course Description</b>	This course provides an in-depth treatment of the methods and techniques used for the implementation of automated device control, both digital and analog. The student will achieve a mastery of both open and closed loop control methods and algorithms including sequencing control, and potential/integral/derivative control. The student will gain hands-on experience with sensor technology, computer-based data acquisition and control, and programmable controllers.
<b>Course Objectives</b>	<p>With the successful completion of this course, students will:</p> <ul style="list-style-type: none"> <li>• be competent in the theory for the control of industrial machines and systems</li> <li>• gain basic skills assisting their life-long practical experiences in controls</li> <li>• understand past and current state of control technologies and forecast the future</li> </ul>

Table 1. Course Description and Objectives

While PLC's remained as the major component, the course modification allowed inclusion of various technologies, connections and contrasts between them, and their past, current, and future roles in industrial controls area. The added content and their details are presented in Table 2. Since a few new components were introduced to the curriculum, main hands-on additions were limited to the hardwired relay-logic and integrated-circuit based controls areas. These components were critical in teaching PLC basics and logic to the students. Besides having hands-on laboratories, demos and review discussions were also utilized in the case of Programmable Automation Controller or PC-based controls.

<b>Added Content \ Laboratory Nature</b>	<b>Hands-on</b>	<b>Demo</b>	<b>Review Discussion</b>
<b>Hardwired Relay Logic</b>	X	X	X
<b>Integrated-Circuit (IC) Based Controls</b>	X	X	X
<b>Programmable Automation Controllers</b>		X	X
<b>PC-Based Controls</b>			X

Table 2. Content addition and their laboratory nature

The new course design was based on three major components, which were presented in the following sequence:

- Theory
- Design and Emulation
- Hands-on Integration

Students studied and understood the theory and basics in a given area, designed and emulated/simulated their control circuit designs, and through hands-on activities the designs were realized. Students finalized their study through an actual team design and development exercise as in the original course. Students were given actual manufacturing engineering design needs and were expected to successfully design and implement their control systems. This paper will elaborate about the course content, the sequence of activities, the related laboratory exercises and technologies, and the student team projects.

### **Modifications Made**

This section elaborates on the modifications made by the instructor and their outcomes.

A new textbook, Programmable Controllers Using Allen-Bradley SLC500 and ControlLogix by Filer and Leinonen, was adopted. The book was simple and effective in presenting Allen Bradley technologies on SLC500 and ControlLogix controllers. Other controllers such as MicroLogix are based on similar technologies to SLC500 and can be covered with use of this book as well.

As mentioned previously, the new curriculum was based on a comprehensive strategy of exposing students to a variety of technologies including past, current, and emerging ones. With this idea, a series of hard-wired logic laboratories were designed and executed before students were exposed to the PLC technology. Hard-wired controls are the basis for today's PLC Technology. Understanding the operation of electromagnetic and solid state relays allowed students to easily learn relay coil and contact elements within PLC's, differences between dummy outputs and actual physical outputs in ladder-logic, or opto-isolation in the interface modules of the controllers. Similar idea was applied to fixed and flexible IC's as well. After mastering Boolean logic, algebra, and different logic families, students were exposed to the flexible IC's that can be programmed once through the use of electricity. The author also decided to present the Programmable Automation Controller technology as a future alternative to today's PLC's. Examples used in presenting simple concepts in class periods and before major laboratories. Laboratory examples simulated real-life examples capturing and maintaining student interest while being effective in teaching. They were collected from a wide variety of resources and some practical issues that the author has faced during his experiences.

Following laboratory components were added under modification attempts:

- Hardwired Relay Logic Laboratories: This section covers the relays (electromechanical and solid state) with such applications as push-button motor starters, directional motor controls, and emergency lighting systems. Generation of logic (combinational and sequential) with relays was also covered. For this section, the author designed and built trainers that included multiple electromechanical relays, DC motors, LED's, and a breadboard as seen in Figure 1. Trainers were designed in an explicit way to allow student access to the circuits they were working on. The results were very positive.

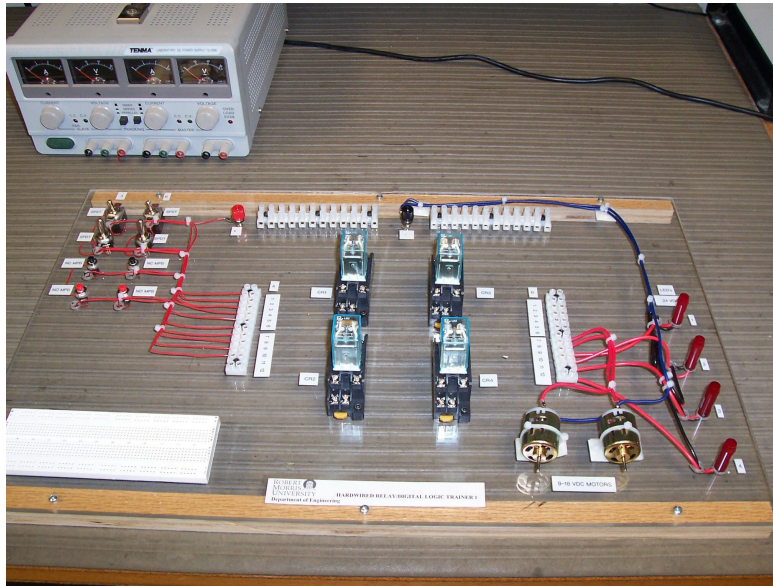

Figure 1. Hard-wired relay logic and IC-based control trainer

- Digital Logic through Fixed and Flexible Integrated Circuits: Students designed and built TTL (Transistor-Transistor-Logic) circuits on the trainer shown in Figure.1. Applications examples included optical gauging systems, box sorters, palletizing, and safety systems. Students were introduced to flexible and programmable integrated circuits as well. They used NI (National Instruments) LabView software in understanding basic logic and control concepts, and designing their laboratory circuits before building them – Figure 2. The simulation capability greatly enhanced the student’s ability to visualize and troubleshoot.

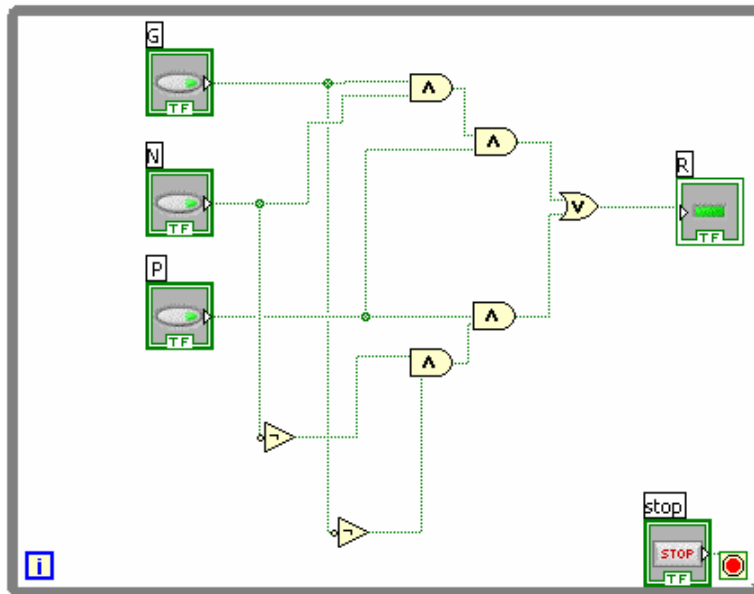

Figure 2. LabView model of an automatic optical gauging station example’s logic

- PLC component remained as the major factor of the course. Additions to this section included introduction of non-Allen Bradley (Modicon and Telemecanique) control hardware and their differences in programming, and Sequential Function Charts. These additions were supported by review exercises rather than hands-on laboratories (as explained before in the background section). The major outcome here was that students were able understand the programming structure of non-Allen Bradley systems with ease giving them greater confidence.
- A new type controller, Programmable Automation controller driven liquid level and temperature controller (as shown in Figure 3) and a PLC driven block sorter mechanism were demonstrated. Programmable Automation Controller (PAC) is a device that combines strengths of PC and PLC controls. The differences between these two technologies were presented as well. The specific controller utilized in the continuous control example mentioned above

was NI Field Point (FP) Controller and was programmed through the LabView software.

The students were also asked to work on a team design project. The author encouraged them to work on an automated work-cell example or an open-design project. Two groups emerged from the eight student body. One group decided to design and build an animatronic penguin, which can be seen in Figure 4. The penguin walked, flipped its wings, and had mouth motions. It also could also shine its eyes through LED's. The control utilized was Allen Bradley's MicroLogix 1000 controller with 24 VDC power requirements making the controller eligible for autonomous or wireless operation. The other group chose to design a simple work-cell for pencil packaging operation. This design can be seen in Figure 5. Basically, pencils with different orientations were supplied to the work-cell through a gravity feeding mechanism. Two optical sensors recognized the presence and orientation of the pencils. If the orientation was incorrect the pneumatic pick-and-place robot reoriented the pencil. Then the robot placed the pencil on a ramp that was leading to a packaging box. The cell was controlled by an Allen Bradley SLC500 controller. During these projects students strengthened their wiring and programming concepts. They experimented with different sensors. The work-cell group had to work with pneumatics, while penguin designer learned about dynamics, mechanism design, and motor selection.

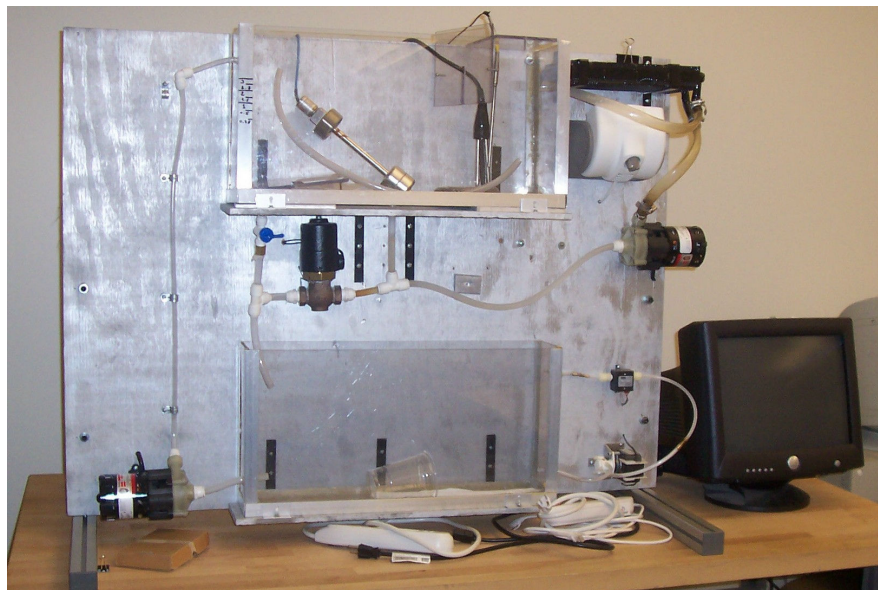

Figure 3. Temperature and level controller driven by PAC technology

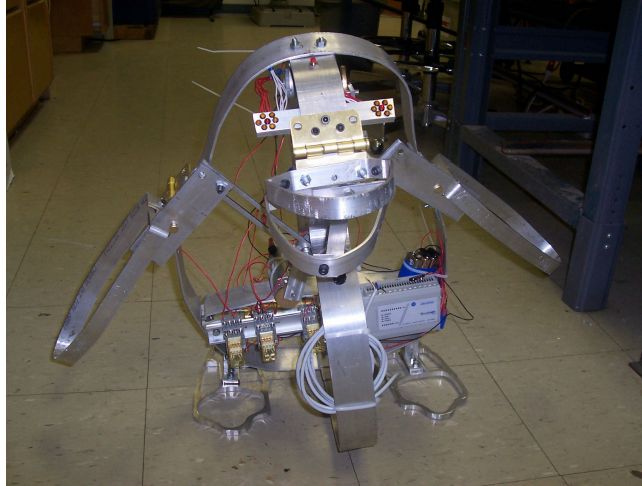

Figure 4. Animatronic penguin – while development in progress

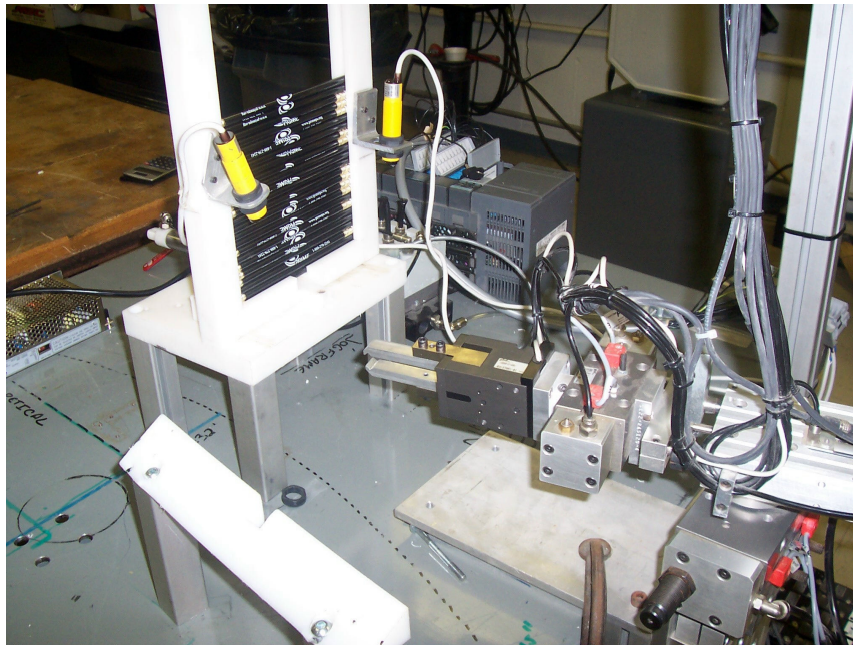

Figure 5. Pencil packaging work-cell

## Results and Conclusions

Throughout the course, student feedback was obtained on a regular basis through direct contact between the instructor and the students. Positive feedback was obtained. Students also showed enthusiasm towards the course components including the projects. Course evaluations indicated student pleasure towards the learning experience and the instructor with high marks. Student grades also reflected a successful experience with more than 80% of the students earning grade B and above. This is the criterion that department uses as a measurement standard for ABET reaccreditation. Most related ABET outcomes also indicated a similar pattern documenting the effectiveness of the approach.

Students gained invaluable experience by being exposed to various technologies. Theory, practice, emulation, and simulation factors were integrated within the curriculum. Students gained experience in hard-wired control circuits, build digital logic through IC's and relays, used a computer design and simulation package in designing control logic. They were also exposed to ladder logic and the block diagrams through NI's graphical programming. Most importantly, they worked on practical examples and exercises that made sense for them. In the process, they integrated multiple components into working systems. However, there were time constraints limiting abilities within certain areas and this was the first attempt of teaching after the modifications were planned. With recent modifications to the department's curriculum, a lab session was added to increase the time allocation on hands-on activities and the projects and to ease the pressure on inclusion of critical background information. With this change, the author is planning to add more content on flexible and programmable IC's and their current and future roles in the controls and more related practical activities. V-SIM which is a PLC emulation software that can emulate PLC programs in real-time is also considered as a new addition to the current PLC emulation abilities.

## References

- [1] Rider, M.J., A Unique, Undergraduate PLC Course, Proceedings of the 2004 ASEE Annual Conference and Exposition.
- [2] Cambron, M.E., Lenoir, H.J., Introduction to Automation, A Multi-Disciplinary Course at Western Kentucky University, Proceedings of the 2004 ASEE Annual Conference and Exposition.
- [3] Condoor, S.S., Application-Centered Methodology for Teaching PLC's, Proceedings of the 2003 ASEE Annual Conference and Exposition.
- [4] Conrad, W., Realistic Laboratories in an Electrical Engineering Technology Controls Course, Proceedings of the 2003 ASEE Annual Conference and Exposition.
- [5] Otieno, A., Mirman, C., A Laboratory Based Programmable Logic Controller Course in Manufacturing Curriculum, Proceedings of the 2003 ASEE Annual Conference and Exposition.
- [6] Cheng Y.L., Crossman, G.R., Automation Laboratory Development with Design Implementation and Simulation Software, Proceedings of the 2003 ASEE Annual Conference and Exposition.