



## Development of a Low-Cost, Low-Voltage Three-Phase Power Synthesizer for Use in Motor and Systems Experiments

### Ms. Kathleen Teresa McGuire

Kathleen T. McGuire is a senior electrical engineering major at the University of San Diego. She is graduating in May and has plans to work for Freescale Semiconductor in Austin, Texas starting this summer. She is part of several engineering honors societies such as Tau Beta Pi and Tau Eta Nu, as well as several other clubs on campus. She is interested in semiconductors and embedded systems.

### Ms. Jessica Urbano

Jessica L. Urbano is a Spring 2015 graduate of the University of San Diego with a dual BA/BS degree in electrical engineering. During her years as an undergrad she participated in several research projects covering topics such as creativity in engineering, a vehicle health diagnostic system, and three-phase power generation. Jessica has always been involved in mentoring younger students and outreach in STEM. As the vice president of SWE and the recording secretary of Tau Beta Pi she was exposed to multiple opportunities within engineering for outreach and involvement. She is entering industry following graduation.

### Prof. Frank G Jacobitz, University of San Diego

Frank G. Jacobitz was born in Göttingen, Germany, in 1968. He received the Diploma in physics from Georg-August Universität, Göttingen, Germany, in 1993, and the M.S. and Ph.D. degrees in mechanical engineering from the University of California, San Diego, La Jolla, in 1995 and 1998, respectively. He has been with the University of San Diego, San Diego, CA, since 2003, where he is currently a Professor of mechanical engineering. From 1998 to 2003, he was an Assistant Professor of mechanical engineering with the University of California, Riverside. He has also been a visitor with the Centre National de la Recherche Scientifique at Aix-Marseille Université in Marseille, France. His research interests include direct numerical simulations of turbulent flows with shear, rotation, and stratification, as well as bio-fluid mechanical problems at the microscale. Prof. Jacobitz is a Member of the American Society of Mechanical Engineers (ASME), the American Association for the Advancement of Science (AAAS), the American Physical Society (APS), the European Mechanics Society (EUROMECH), and the Deutsche Physikalische Gesellschaft (DPG). He currently serves as the faculty advisor to the student section of the ASME at the University of San Diego and the President Elect of the Pacific Division of the AAAS. He received the Outstanding Engineering Educator Award from the San Diego County Engineering Council in 2008, the Faculty of the Year Award from the Zeta Omega Chapter of Beta Theta Pi Fraternity in 2013, the Outstanding Undergraduate Research Mentor Award from the University of San Diego in 2014, and Best Paper Awards from the Division of Experimentation and Laboratory Oriented Studies of the American Society for Engineering Education in 2008 and 2014.

### Dr. Ernest M. Kim, University of San Diego

Ernie Kim received his BSEE from the University of Hawaii at Manoa, and MSEE and PhD in Electrical Engineering from New Mexico State University. He has been an electronics engineer at the National Bureau of Standards (now NIST) at the Boulder CO labs where he performed research on precision optical fiber metrology, staff engineer with the Advanced Systems Group of Burroughs Corporation, Manager of Electro-Optics at Iptek Corporation where he developed early fiber optic CATV systems. Dr. Kim has worked at a number of start-up companies in fiber optic transmission including All Optical Networks, and Lightwave Solutions in San Diego. He joined the University of San Diego Department of Electrical Engineering in 1990. Dr. Kim is a licensed Professional Engineer (EE), and regularly teaches FE and PE exam review courses.

### Dr. Thomas F. Schubert Jr. P.E., University of San Diego

Thomas F. Schubert, Jr. received his B.S., M.S., and Ph.D. degrees in electrical engineering from the University of California, Irvine. He is currently a Professor of electrical engineering at the University of



Seattle

**122nd ASEE Annual  
Conference & Exposition**

June 14 - 17, 2015  
Seattle, WA

*Making Value for Society*

Paper ID #13323

San Diego, San Diego, CA and came there as a founding member of the engineering faculty in 1987. He previously served on the electrical engineering faculty at the University of Portland, and Portland State University, and on the engineering staff at Hughes Aircraft Company. Prof. Schubert is a member of ASEE and IEEE and is a registered professional engineer in Oregon. He is the 2012 winner of the ASEE Robert G. Quinn award for excellence in engineering education.

# Development of a Low-Cost, Low-Voltage Three-Phase Power Synthesizer for Use in Motor and Systems Experiments

## Abstract

The electrical engineering program at the University of San Diego has revised its curricular treatment of electrical power and electrical machines at several levels and for students in all engineering majors. Included in that change was a decision to limit students' first exposure to three-phase systems to voltage levels less than 25V and power levels less than 5W. Cost, safety, and the desire to have a meaningful three-phase laboratory experience for students with minimal prior knowledge of the subject were the major factors in making that decision. Another driving factor was the availability of low-voltage three-phase motors commercially available at very low-cost (under \$10), but disguised as three-phase generators in a variety of "green" consumer products.

Several years ago, three initial synthesizers were prototyped using discrete digital and analog components and tested, with positive results, on sophomore students in diverse engineering majors. Unfortunately, none of the prototypes were, at that time, developed into practical, stand-alone devices.

The project was reinitialized this year with the purpose of developing a practical, stand-alone, three-phase power synthesizer that could be dispersed throughout the educational community at low cost. A team at the University of San Diego has designed such a unit and is assessing its usage in a sophomore circuits laboratory setting as well as by junior-level electrical engineering students in an electrical power course. Assessment results and a full design description of the unit are presented here.

## Introduction

In 2009, the treatment of electrical power and electrical machines for all engineering disciplines was under revision. One of the topics covered in the sophomore level *Introduction to Circuits* course was three-phase power, but it was only covered in a few lectures and the majority of students obtained only cursory understanding. To further explore three-phase power, the professors wanted to implement a lab relating to the material covered in lecture. To be able to demonstrate three-phase power in a laboratory setting proved to be difficult due to monetary and safety restrictions.

The labs are equipped with a single 208VAC (line voltage—120 VAC phase voltage) three-phase outlet. However, the sophomore students at the University of San Diego have never worked with voltages above ~30 V or power levels more than ~5 W. The time and resources required to prepare the students to work with the high voltage three-phase power was not seen to be realistic. At this time, the professors developed six separate solutions for three-phase synthesizers that could power a small DC motor. The six proposed solutions were:

- Transformers in a Y-configuration (a three-transformer solution),
- Transformers in a  $\Delta$ -configuration (a two-transformer solution),
- Analog synthesis using synchronized oscillators,
- Digital synthesis using synchronized counters, D/A conversion and wave shaping,
- Digital synthesis using EEPROMS and D/A conversions,
- Digital synthesis using a microprocessor and D/A conversion

The digital solutions using synchronized counters and EEPROMS were tested<sup>1</sup>.

Further development of the project was not continued following the initial test of these synthesizers. The project was picked up again in 2014 and the solution that was developed and tested this time was digital synthesis using a PIC18 microprocessor and D/A conversion. This solution will be used to demonstrate the basic concepts of balanced three-phase power in an introductory setting.

## **Project Goals**

The basic project goals are based on the project goals from the article “Synthesis of Low-Voltage Three-Phase Power for Use in Low-Cost Motor and Systems Experiments at the Sophomore Level”<sup>1</sup>. Some variation has been made to the goals but the overall scope of the project has not changed. The goals are:

- to develop a meaningful three-phase system for sophomore engineering students who have only introductory knowledge of three-phase power
- to improve student knowledge concerning the basics of those systems
- to give the students increased confidence in applying the knowledge obtained
- to work at voltages and currents that are safe for lower-division students
- to develop a set of experiments, and associate laboratory equipment that could be easily scaled up to at least 10 identical lab stations at a reasonable cost

In order to reach these goals the team took the following steps:

- researched various microprocessors and Digital to Analog Converters (DACs) and chose best option
- designed, tested, and built a three-phase synthesizer to meet the set parameters described below
- developed an experiment for sophomore level laboratories
- assessed student gains in knowledge and confidence due to the lab experiences

Throughout the course of the research project the following parameters were set as guidelines for the synthesizer:

- Identical output phases separated by  $120^\circ$
- Y-connected
- Variable frequency
- Variable amplitude
- Power output of  $\sim 2\text{W}/\text{channel}$  to allow for power of motor

Each of the preceding steps and parameters will be discussed throughout the course of this paper.

## **Design Outline**

The team decided to create a synthesizer using a microprocessor and D/A conversion for several reasons. There are many available microprocessors that are affordable and have a surprising amount of capabilities. Also, using a microprocessor allows for more flexibility when it comes to making changes and experimenting with different ideas. The digital approach allows for easy amplitude and frequency variations and a stand-alone low-voltage source.

### *Solution Overview*

The overall process of our solution is to have the microprocessor output a sine wave into three separate, external DACs. The output of the DACs will then be filtered and amplified using a low-pass filter and class B amplifier. The high-level block diagram is shown in Figure 1.

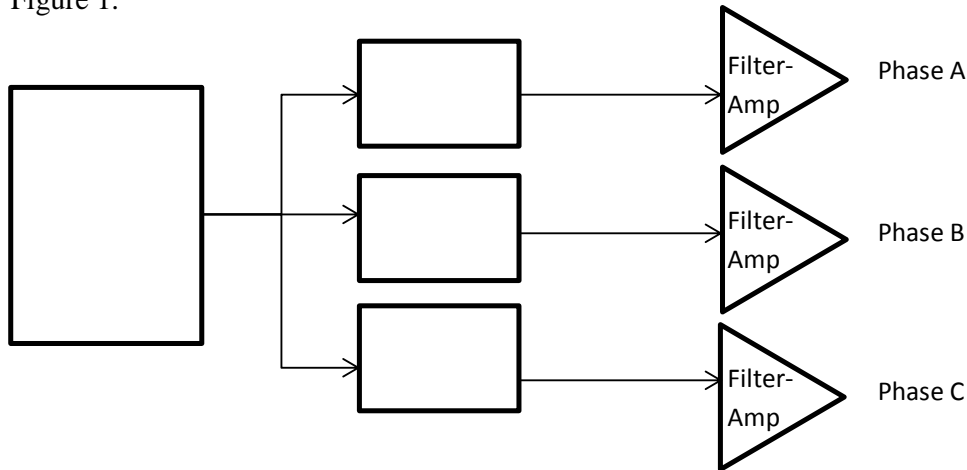

Figure 1: High-Level Block Diagram for microprocessor-based low-voltage three-phase source

### *Selection of Microprocessor*

There are numerous microprocessors that would fit the requirements for the synthesizer since only basic components are required. The team decided to use three external DACs where each received a sine wave from the microprocessor. The sine wave was shifted  $120^\circ$  for each DAC. Initially, it was not decided if the sine wave would be directly outputted or if it would be stored in an EEPROM so a microprocessor with an internal EEPROM that had sufficient memory for a sine wave was selected. Beyond that parameter, the only considerations were cost and ease of use. Since the team had some background using Microchip PIC18 microprocessors they looked into those products. Microchip also provides free development tools that are easily accessible and simple to use. The team ended up selecting the PIC18LF25K80 since it had a 1024 byte EEPROM and was low cost at only \$2.85 per PIC (purchased on October 15<sup>th</sup>, 2014 from Microchip Direct). The team also chose to use Microchip DACs so there would be no compatibility issues. They selected DAC4801, a basic serial DAC that costs \$1.13. The team used MPLABX to develop and a PICKIT3 for debugging.

### *Design and Test*

The team used discrete components for the first stage of development for the synthesizer. A lookup table with the sine values was programmed into the microprocessor and then the values from the lookup table were output to the three DACs synchronously with  $120^\circ$  separation between each DAC. The outputs from the three DACs could then be hooked up to a four input oscilloscope so the phase shifts could be viewed. The initial setup of the board and the schematics can be seen in Figures 2 and 3 respectively. Figure 2 shows the proto board setup which shows that this is a very simple setup that be implemented quickly and inexpensively. In the schematic, only phase A is shown, but all three phases will have the same setup. The blue box indicates the filter-amp setup, but it has not been tested by the team at this point in the process. The output, showing the three phases, on the oscilloscope is shown in Figure 4. The amplifier and filter have not been implemented at this point, but they

will be used to create higher purity sine waves and assure there is sufficient power to run a small motor. These components will be designed and perfected in spring 2015. Currently the three sine waveforms are separated in phase by  $119.77^\circ$ ,  $120.04^\circ$ , and  $119.90^\circ$ . See Figure 4 below for the screen capture of all three waveforms. The total harmonic distortion measured for each unfiltered phase ranges from 4.6-4.8% which we found to be an acceptable percentage. The waveforms have significant high-frequency noise: we expect the harmonic distortion to decrease significantly when we implement the low-pass filter in the amplifier stage.

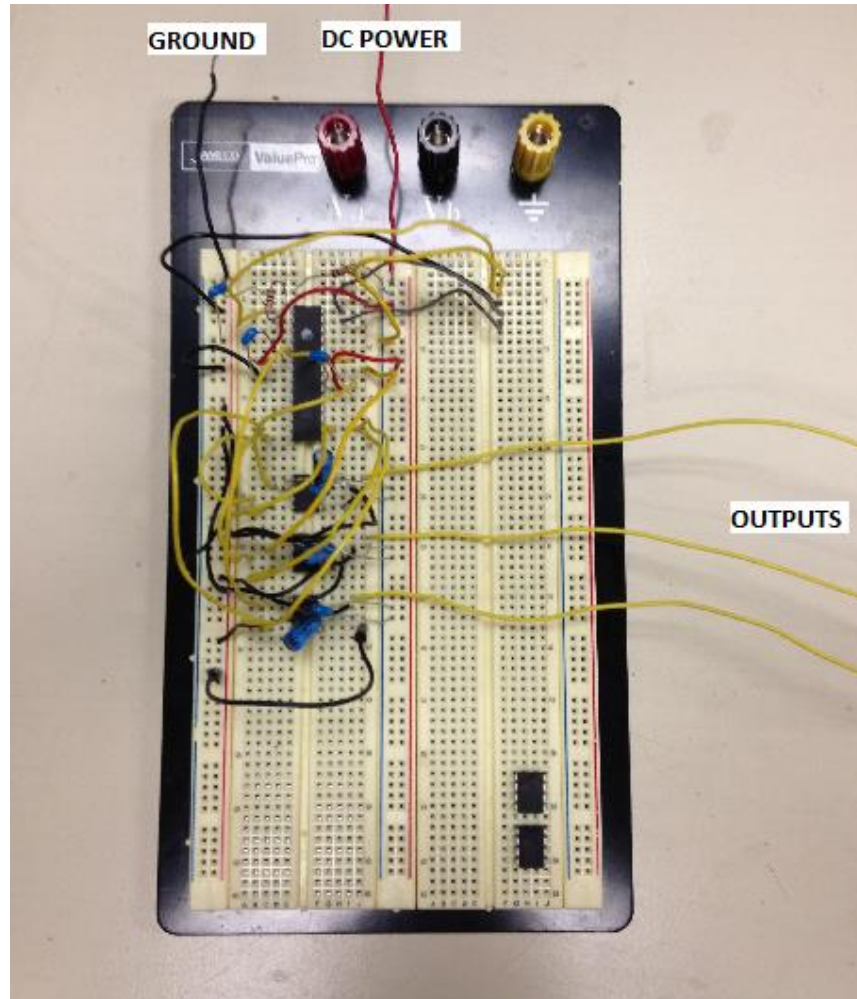

Figure 2: Initial Setup with Discrete Components

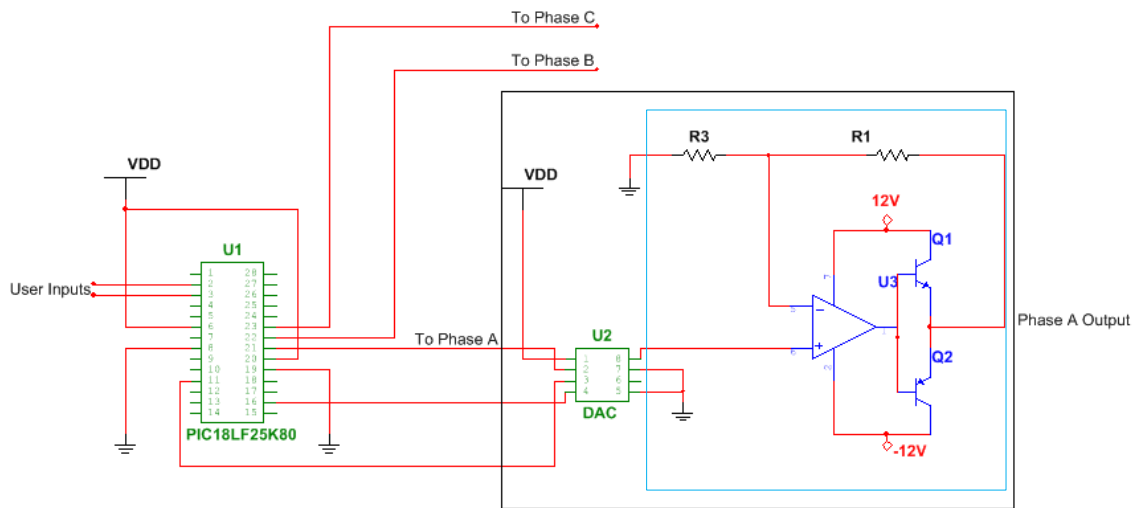

Figure 3: Schematic of Design

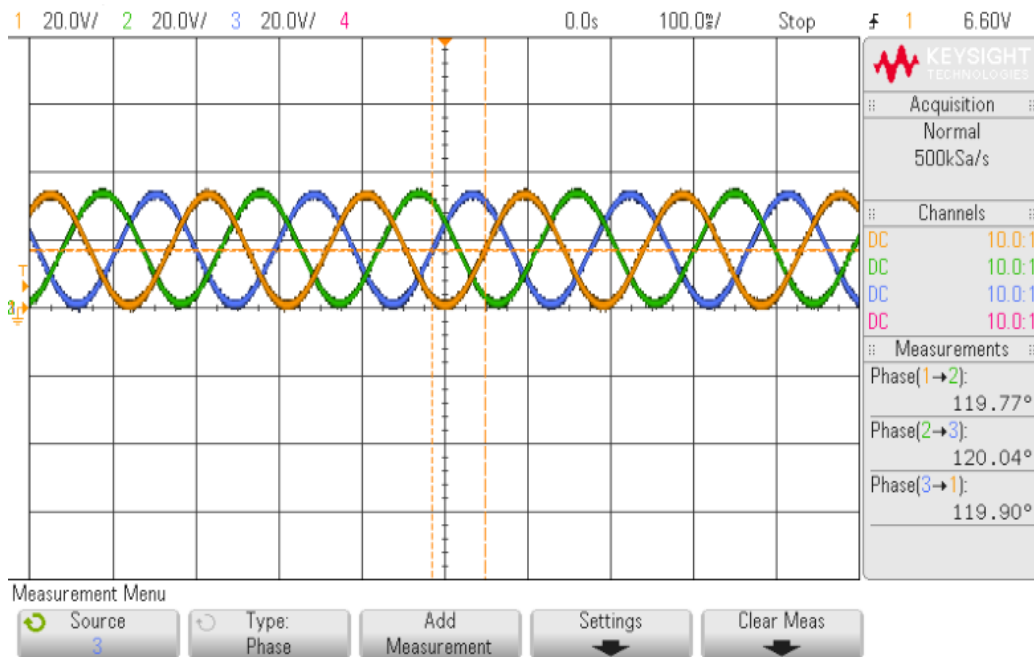

Figure 4: Screen Capture of Three Phase Waveforms

### Experiment

The experiment the team designed is meant to help increase the understanding of the basic principles of balanced three-phase system relationships. Throughout the lab, students will verify that there are specific phase relationships between line and phase voltages and currents, as well as that the three phases of sinusoids themselves are balanced in a constant manner. The simple relationship between Y-connected and  $\Delta$ -connected loads will also be demonstrated, as well as the idea of the relationships between line and phase voltages staying

constant regardless of Y-connected load or its equivalent  $\Delta$ -connection. The complex power of each phase would be computed and compared to one another, showing that the complex power is the same in each phase. To perform this experiment, the students will utilize the device built to generate the three-phase power, as well as a digital multimeter, oscilloscope, and basic circuit design components (a breadboard, resistors, and capacitors).

The experiment is organized into two main parts: the first looks at the three-phase system using a Y-connected load, and the second using a  $\Delta$ -connected load.

In the first section of the lab (Part 1), students are asked to create a balanced Y-connected load by connecting a  $330\Omega$  resistor and  $10\mu\text{F}$  capacitor in series, and repeating this two more times with the resistors all going to a common ground. Once created, the students measure the load phase voltages and load line voltages using the oscilloscope. Comparisons between the measurements observed and expected are made. They then measure the phase current and load line currents and compare this to the corresponding voltage to understand the magnitude and phase relationships between currents and voltages in balanced three-phase systems.

In the second portion of the lab (Part 2), students create a  $\Delta$ -connected load by using the same components as in the Y-connected load. The components, which before shared only a common ground at the resistors, are arranged so they are all in series with each other, creating the  $\Delta$ -connection. For this part of the lab, 3 times the value for the resistors will be used to obtain similar results as in part 1. Then the same measurements and comparisons are obtained as in Part 1. The results of Part 1 and Part 2 are compared and observations are recorded.

In the trial run of the experiment, the team modified the above stated experimental procedure. There was not sufficient time during the lecture periods to properly introduce the lab and its concepts in the Fall 2014 semester, so these modifications were introduced so that the students would understand the subject matter. The device had not yet been modified to allow amplitude and frequency variation so that portion of the lab was omitted. In the future (starting in Spring 2015), the experiment will be performed as stated in this section, not in the manner of the trial run. In the trial run, the following modifications were made: Before starting the actual experiment section of the lab, the team gave an introductory lecture to three-phase systems and their uses. The team built the loads and performed the measurements on the oscilloscope, demonstrating how to obtain the data as well as explaining what the data signified. This lab therefore was not as hands-on as desired, but instead was more of a demonstration, which introduced the students to three-phase systems and their basic properties.

### **Assessment/Observations**

The assessment is meant to ascertain the usefulness of the three-phase synthesizer in helping sophomore-level students gain a better understanding of the properties of three-phase power. The assessment is in the form of a questionnaire, which is given to the students at the beginning and end of the lab session. The questionnaire is designed to indicate whether or not the students find that the lab increases their understanding of three-phase systems, as well as their confidence in being able to manipulate three-phase systems and extract necessary data.

The questionnaire uses a mixture of short response questions as well as questions which require answers based on a scale from 1 to 5 with the ranking descriptions provided below:



- 1= No clue, this concept is new to me
- 2=Low, I have only heard about the concept
- 3= Moderate, I knew the concept but have not applied it
- 4=High, I know the concept and have tried it
- 5=Superb, I know the concept and have successfully applied it

After the lab, the team analyzed the results obtained through these surveys. The questionnaires for each student, the before and after, are connected together so as to be able to see individual changes per student. The students were not asked to put their names on any of the documents as to keep confidentiality.

In the trial run of the experiment, as stated above, the procedure was modified to fit several constraints. Therefore, some of the assessment questions that will be part of the survey in the future experiments do not apply to the students who participated in the first trial. Also, it is to be kept in mind that the students have had very little exposure to three-phase power concepts during their class lectures. As it is, there were a total of ten students from an introductory circuit design class who participated in the assessment. Table 1 below shows the relevant questions from the first demonstration as well as the results. There is expected to be more data from a wider base of students in the Spring 2015 semester.

Table 1: Distribution of results from assessment

Question Posed to Students	When	Distribution					Incremental Change								Average Change	
		1	2	3	4	5	-4	-3	-2	-1	0	1	2	3		4
How well do you understand three-phase power?	pre	3	5	2	0	0	0	0	0	0	2	6	0	2	0	1.2
	post	1	2	3	3	1	0	0	0	0	2	6	0	2	0	
How comfortable would you be working with a three-phase generator in a lab?	pre	6	2	2	0	0	0	0	0	3	4	0	1	2	1.5	
	post	2	1	3	2	2	0	0	0	0	3	4	0	1		2
How well do you understand the differences/similarities between Y-connected and Delta-connected loads?	pre	6	1	3	0	0	0	0	0	3	2	3	1	1	1.5	
	post	1	1	4	3	1	0	0	0	0	3	2	3	1		1

Overall, the results were positive. There was either no change or a positive change for each of the questions which the team considers a success.

**Observations/Improvements**

The data used in this paper is from a trial run of the lab in which students use the device. In this first run, the students observed the results of all the lab portions on the oscilloscope as the team walked through the procedure of the lab. They were able to view the 120° phase separation between current and voltage as well as relationship between line voltage and phase voltage. Although this allowed the students to see the relationships of the three-phase power system, it lacks the hands-on experience that the team ultimately desires for the students. In

the upcoming renditions of the lab, the students will follow a written procedure and create the measurements and gather the observations on their own. The team hopes to implement the lab by spring 2015 in at least three more sophomore-level Circuits courses (60 or more students) as well as an upper-division Introduction to Power course in order to collect more data and feedback on how to improve the synthesizer.

The team also plans to add amplitude and frequency variation capabilities to the synthesizer and add components to the lab so that students can observe how these affect the behavior of the three-phase systems and will simplify the use of the synthesizer with motors. It will also provide flexibility so more labs can be created in the future.

In regards to the design of the three-phase synthesizer, the team plans on moving from discrete parts to PCB, as well as add in a few components: Currently the device consists of a microprocessor and several digital to analog converters. We plan on adding power amplifiers and filters for better quality signals. This will also allow for better ease of use in the labs and much less troubleshooting will be required.

## **Conclusion**

This project sought to create a low-voltage three-phase power synthesizer that can be used in lower-level labs in a university setting. The overall results were positive after an initial demonstration with the synthesizer. The students all increased their knowledge in one or more areas relating to three-phase power after the demonstration. The team is confident that the positive results will only increase as the students start doing the hands-on lab and more time can be spend covering the information with them. The overall goal - to increase the understanding of three-phase power - has been accomplished and improvements will be made throughout spring 2015. At the conference presentation, results of the spring improvements, updated schematics, and the lab procedures will be presented and available to attendees.

## **References**

- [1] Schubert, T., Jacobitz, F., Kim, E. (2010). Synthesis of Low-Voltage Three-Phase Power for Use in Low-Cost Motor and Systems Experiments and the Sophomore Level. *2010 Annual ASEE Conference and Exposition*
- [2] Welch, T., Berry, J. (1996). Teaching Three Phase Electrical Power Using a Low Voltage Power Source. *1996 Annual ASEE Conference Proceedings*