

## **DEVELOPMENT OF A WHEEL STOP MECHANISM FOR A WHEEL ALIGNMENT MACHINE**

**Vladimir Sheyman, Mulchand S. Rathod, Greg D. Coe**  
**Division of Engineering Technology**  
**Wayne State University**  
**Detroit, MI. 48202**

Tel: (313) 577-0800; Fax: (313) 577-1781  
E-mail: rathod@et.eng.wayne.edu

### **SUMMARY**

This paper is based on a senior design project. It is an example of a complete work from conception and design to implementation in the industry. This project also shows how the industry benefits from supporting curriculum based projects.

In design process of any device, there exists a magnitude of considerations and a challenge for the engineering professional to recognize all the issues in an appropriate proportion. One of the most important considerations is safety. In this project, a safety mechanism on a wheel alignment machine was designed, fabricated, tested, and implemented in industry. The wheel stop mechanism is either installed on the drive side of the wheel alignment machine or on both sides of the vehicle based on the customer safety standards. In case of an accident, while the measuring heads reading the alignment of the tires, the wheel stop mechanism prevents harm to the operator, alignment machine, and the plant assembly surrounding. If the automobile transmission were somehow knocked out of neutral and put into drive position while the measuring process would be taking place, the wheel stop prevents it from moving forward.

This project resulted in introduction of a new wheel stop mechanism for a wheel alignment machine in the automotive industry. The unique frame of the machine is much more compact than the standard

one. It does not stand in a deep pit of the assembly plant floor. This wheel alignment machine is located right on the top of the floor. There is no additional adjustment tooling that would come up from the bottom of the vehicle.

The design of the wheel stop mechanism has been drawn in Mechanical Desktop V4 – 3D CAD system. Important calculations and tests were also made to assure the durability of components. They are designed to withstand the impact and to check if the mechanism would meet the requirements and specifications. As it was mentioned earlier, this device was implemented in industry and it was fully functional in an improved setting.

### **INTRODUCTION**

As fully assembled automobiles come off the assembly line, they go through a variety of tests. In many cases, some vehicles need minor adjustments. One of the tests needed is the headlamp and wheel alignment test. The operator carefully drives the vehicle onto the wheel alignment machine where the front axle is even with the measuring head. During this process, the tires rest on two rollers. Once the measuring heads recognize that the tire is in proper place, a signal is sent to activate the air cylinder on the wheel stop mechanism causing it to open. While the measuring process is taking place, this new device would act as a stop just in case the vehicle somehow is put into the drive motion. It

would also prevent damage to the alignment machine, its operator, and the surrounding assembly.

The problem with the existing style of wheel alignment machines is that the standard wheel stop mechanism cannot be used because of being not mounted to the machine frame. The solution to this problem was a new compact design that would be as durable as the standard one.

The wheel stop is an optional feature on the wheel alignment machine. It is either installed on the driver side of the machine or sometimes on both the sides of the vehicle depending on the safety standards. This paper addresses the issue of safety mechanism on a wheel alignment machine. A wheel stop safety mechanism was designed, manufactured, beta tested, and introduced to the automotive industry. This new type of vehicle wheel alignment machine would sit right on top of the floor. As a result, no additional adjustments tooling coming up from beneath the vehicle is needed. Some of the optional tooling requiring caster/camber adjustments would be removed. Also, the toe setting that requires a considerable amount of space under the front axle of the vehicle would be completely eliminated.

A unique frame of this machine is much more compact in comparison to standard frame. It does not stand in a deep pit in the assembly plant floor. With the new design, limited space and clearance problems are eliminated. Also, addressed are the issues of durability and safety factors.

A number of wheel stop designs on a variety of machines were examined. Each wheel alignment machine frame was different which lead to different mounting of the wheel stop. This caused each design to be unique with respect to a particular wheel alignment machine. Also, some existing wheel stop mechanisms are specially designed as stand alone units. They are not

suitable for new alignment machines. The main reason for this improved design was to create a system adaptable to practically all the units. It would mount to the alignment machine frame allowing simple design and more compact mechanism. This is the fundamental difference between the existing wheel stop mechanisms and the new design.

## **WHEEL STOP MECHANISM**

Figure 1 shows a general view of the wheel stop mechanism. It shows the centerline of the vehicle to the outside of the wheel alignment machine. This view also depicts a section cut away from the wheel alignment machine frame for clarity. The deck plating on the top of the machine is at floor level and has a hole burned out for the wheel stop to open up. When the wheel stop is in its full up position, it extends 4.3125" above the floor level. The vehicle clearance from the floor level is approximately 4.5" giving only 0.1875" clearance. That means when the wheel stop is in its working position, there is very little space to work with.

Figure 2 shows the wheel stop mechanism in down position. There is a burned out hole for the wheel stop to open up. When it closes, the floor plate is flush with the surrounding deck plating. The wheel stop is welded to the cross tubes of the machine frame. When the vehicle would drive over, the weight force would be distributed directly to the base of the unit. It is welded along entire sides to create a strong bond between the two. This causes the stress on the wheel stop to be minimum from the weight of the vehicle. The majority of the weight force is directly transmitted to the part of the base. This is where the floor plate would be attached and is in total compression.

Figure 3 shows a complete assembly view of the wheel stop mechanism in its working position. Each individual detail was created using different layers or colors to distinguish one component from another.

The following is a partial list of components:

- |               |                 |
|---------------|-----------------|
| 1. Base       | 3. Top pad      |
| 4. Carriage   | 7. Link         |
| 8. Link arm   | 9. Trunnion     |
| 11. Stop      | 13. Floor plate |
| 16,17. Spacer |                 |

Purchased parts:

- P1. Pneumatic cylinder
- P2. THK Linear motion system
- P3. Shaft
- P13. Bronze sleeve bearing

By creating the components, it is very useful to draw indifferent layers because there exists an option to freeze layers. When a layer is frozen, it means that the layers would be turned off. In this particular diagram, the geometry of the surrounding frame of wheel alignment machine is turned off in order to consider the wheel stop mechanism itself.

The base is welded steel that consists of three different parts and it is the foundation of the wheel stop unit (1).

The *Parker Pneumatic Cylinder* (P1) is the power source of the wheel stop mechanism. The LP/LM series is a low profile air cylinder designed and built to meet space saving needs. This type of air cylinder is sometimes known as a pancake air cylinder. Its features include permanent lubrication, piston rod with seals, light weight, and operating temperature range of 10 F to 200 F. The piston rod is made from high strength steel and hard chrome plating for longer life. The cylinder housing is hard coated for excellent wear, seizure, corrosion resistance, and low friction coefficient properties. This cylinder has 3" bore diameter and a pulling force of 389 lbs at a line pressure of 60 psi. For the wheel stop mechanism, a 3" stroke is desired along with the trunnion mounting style.

The *THK linear motion system* (P2)

is a very important part of the design. It is responsible for providing a slide for the carriage (4) which produces a horizontal motion from the air cylinder (P1). Two systems are required to complete the assembly. As the carriage slides along the rail, it forces the wheel stop to lift open. One significant point about this system is that it has no lost motion. Hence, the positioning is very accurate and a high speed movement is possible if necessary. These linear systems have little friction resistance and very little wear on the slide surface. High accuracy can be maintained for a long periods of time with minimal lubrication and maintenance. The rail is mounted on each side of the base (1).

Figure 4 shows an assembly view of the wheel stop mechanism in working position. It is rotated in a mirror image from Figure 3. The top cover layer was turned off to show more of what is going on underneath it. Connections between different components are very visible here and also the main details are shown clearly. This helps to understand the workings of the wheel stop mechanism. Additional components included in this view are:

- |                  |              |
|------------------|--------------|
| 2,14. Shaft      | 6. Outer arm |
| 12. Cranking arm | 15. Roller   |

Purchased parts:

- |                    |                     |
|--------------------|---------------------|
| P5. Set screws     | P6. Cam follower    |
| P8. Thrust bearing | P12. Sleeve bearing |

The *outer arm* (6) consists of 4 different steel pieces welded together. It shows the main detail of the stopping portion including the shaft being exposed to stresses in case of an impact force. One outer arm is required to complete the wheel stop assembly. This detail is symmetrical about the centerline of the air cylinder. The outer arm has many precision holes for shafts that connect this detail to its various mating details.

The roller (15) is a cylindrical object

made of UHMW virgin polyethylene [1] needed to absorb impact energy and abrasion [2]. The roller is a housing for the shaft (2) and serves as a bumper to reduce stress on the shaft in case of collision. Another view of the wheel stop mechanism is shown in Figure 5 to help understand its working.

## MECHANICAL FUNCTIONING

Once the air cylinder fires, it pulls on the cranking arm forcing it to rotate counter clockwise. It is connected to the link arm with restricted movement. The link arm would be pushed forward causing the carriage to move horizontally along the THK linear motion system. Since one end of the carriage is connected to the outer arm, it would be forced upward as the carriage rides along the THK linear motion system. It would force the wheel stop mechanism to open up. There is a chain reaction among components. An air cylinder force would eventually create a movement in a horizontal plane. Because of component linking, final outcome is the opening of the wheel stop. The cylinder stroke is set at a specified length using the threaded rod end on the air cylinder. This particular air cylinder has a stroke of 3" adjusted to 2.125" leaving 0.125" to go. The remaining stroke provides cushion inside the bore because of availability of more room for travel.

The cranking arm has a setscrew on each end requiring adjustment to control rotation. The wheel stop can only be so high when it is open to eliminate interference with vehicle front fender. Over-rotation of wheel stop would crash into the fender. While adjusting the setscrews, they should extend past the bottom of the block 0.25". This would allow approximately 0.1875" clearance between the highest point on the wheel stop mechanism and the vehicle fender.

During the design phase, many calculations are performed using techniques available in the literature [3,4,5]. Among

them are techniques for designing arm length and angle to get the maximum force from air cylinder; air cylinder force to lift the mechanism; and stresses on the shaft due to an impact force from the mechanism. Those calculations are not presented in the paper due to space limitations.

## CONCLUSIONS

In the design of new devices, safety plays a significant role in today's litigious society. The safety feature in the wheel alignment machine was an import criterion. At the same time, the design was effective, reliable, and durable. The compact size of the mechanism provided the biggest challenge of all. This happened because the wheel stop was only 6.375" tall while in down position compared to the standard wheel stop being 17" tall. Stress calculations assured the integrity of various shafts and parts resulting in no failure modes.

Various wheel stop designs on a number of machines were examined. It was noted that they all serve the same purpose even though the designs might differ. Different design were needed for different wheel alignment machines. The wheel stops were used on wheel alignment machines as well as on roll and brake test machines for heavy duty versions. All the designs did have the same concept and were intended to make the machines safer. This main design recommendation was adopted and applied.

## REFERENCES

1. Obert, E., et al, "Machinery Handbook," 25<sup>th</sup> Edison, p 370.
2. Lindberg, R.A., "Processes and Materials of Manufacturing," Allyn & Bacon, Inc., year?
3. Gere, J.M., Timoshenko, S.P., "Mechanics of Materials," PWS Engineering, Boston, MA, year?
4. Juninsll, R.C., Marshek, K.M., "Fundamentals of Machine Component Design," 3<sup>rd</sup> Edison, p 263.
5. Beer, F.P., Johnston, E.R., "Mechanics

of Materials,” 2<sup>nd</sup> Edison, p 191.

## BIOGRAPHY OF AUTHORS

**Vladimir Sheyman:** Vladimir Sheyman received his Ph.D. in Mechanical Engineering from the Academy of Sciences, Minsk, Belarus. Prior to joining WSU Division of Engineering Technology in 1986, he worked in industries. His areas of interest include heat and mass transfer and thermal sciences. He has published monographs and over 90 papers, and has received patents for 27 inventions.

**Mulchand S. Rathod:** Mulchand S. Rathod, Ph.D., P.E. joined WSU as Professor and Director of the Division of Engineering Technology in 1987. He earned his B.E. (Mechanical) degree from Sardar Patel University in 1970; and M.S. in 1972, Ph.D. in 1975, both in Mechanical Engineering from Mississippi State University. At WSU, he has been instrumental in starting four new undergraduate and a graduate program. He established student chapters of SME and Tau Alpha Pi and is the founding leader of the Professional Order of Engineering Technology.

His prior appointments include State University of New York at Binghamton, Tuskegee University, Jet Propulsion Laboratory, and IBM. A registered Professional Engineer, he is active in ASME, SME, ASHRAE, and ASEE. He has served as a Commissioner on the TAC of ABET. A holder of numerous publications and inventions, he is listed in several Who's Who publications. He was awarded the 1995 Dedicated Service Award, 1998 Ben C Sparks Medal, and 2001 BMW Award by ASME and Certificates of Recognition by NASA and IBM for technical innovation. Also, a recipient of numerous grants and contracts and a Fellow of ASME, Dr. Rathod is a nationally known leader in Engineering Technology education community.

**Gregory D. Coe:** Gregory F. Coe earned his BSET degree from WSU in 2000 and earned the MSA degree from Central Michigan University in 2002. He has worked in automotive industry for several years in various capacities.

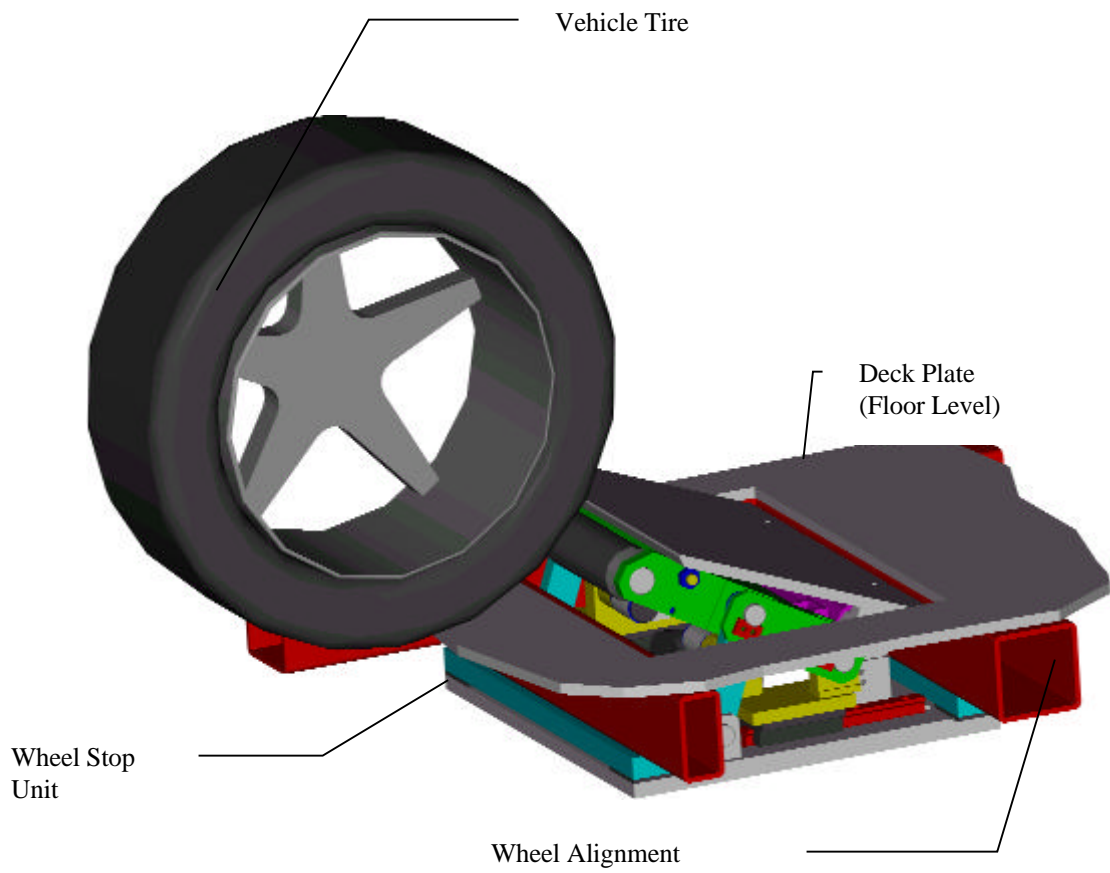

Figure 1. Working Assembly (Up Position) – Cut Away Section View

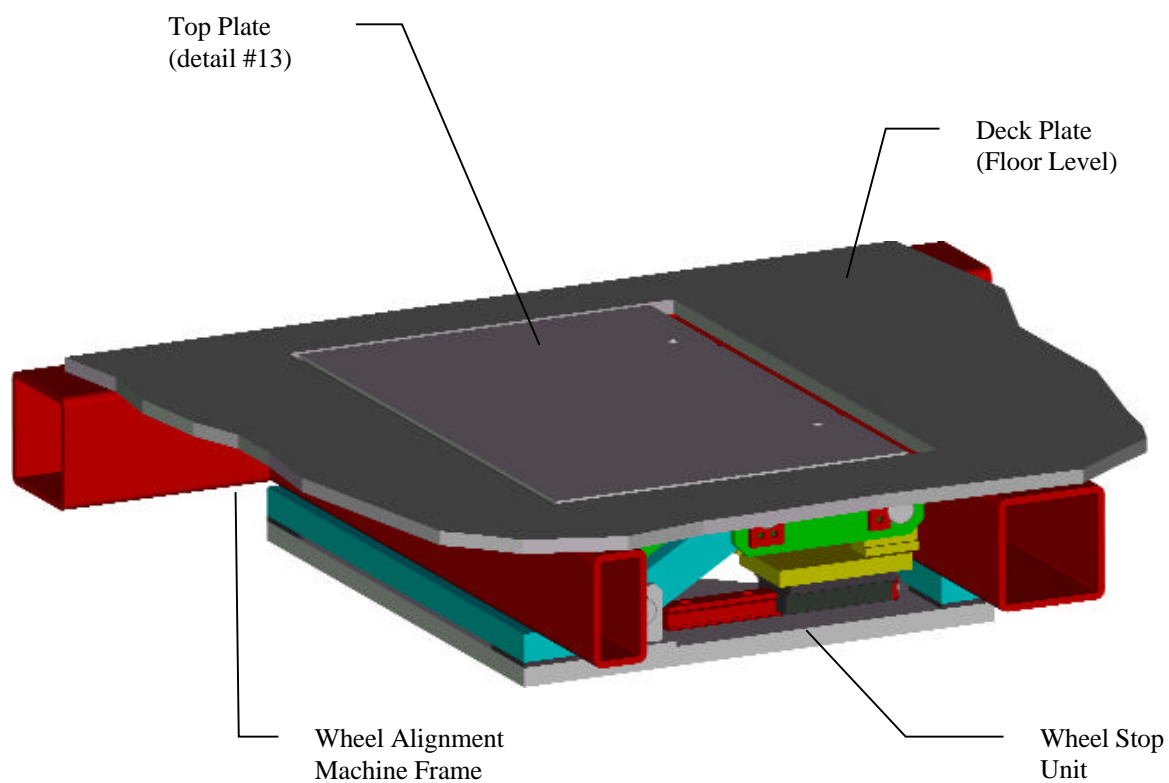

Figure 2. Working Assembly (Down Position) – Cut Away Section View

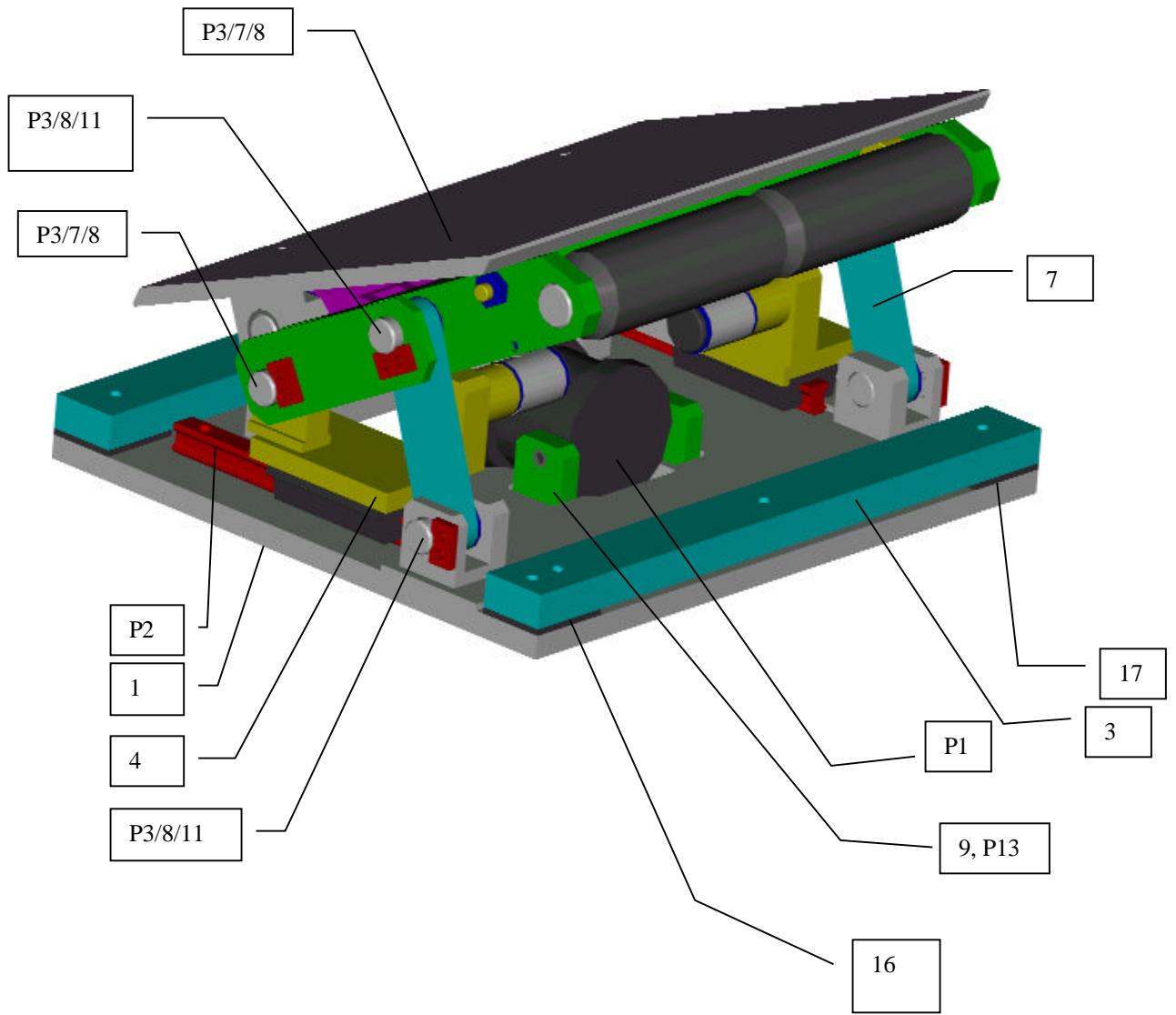

Figure 3. Complete Assembly (Up Position)– Isometric View



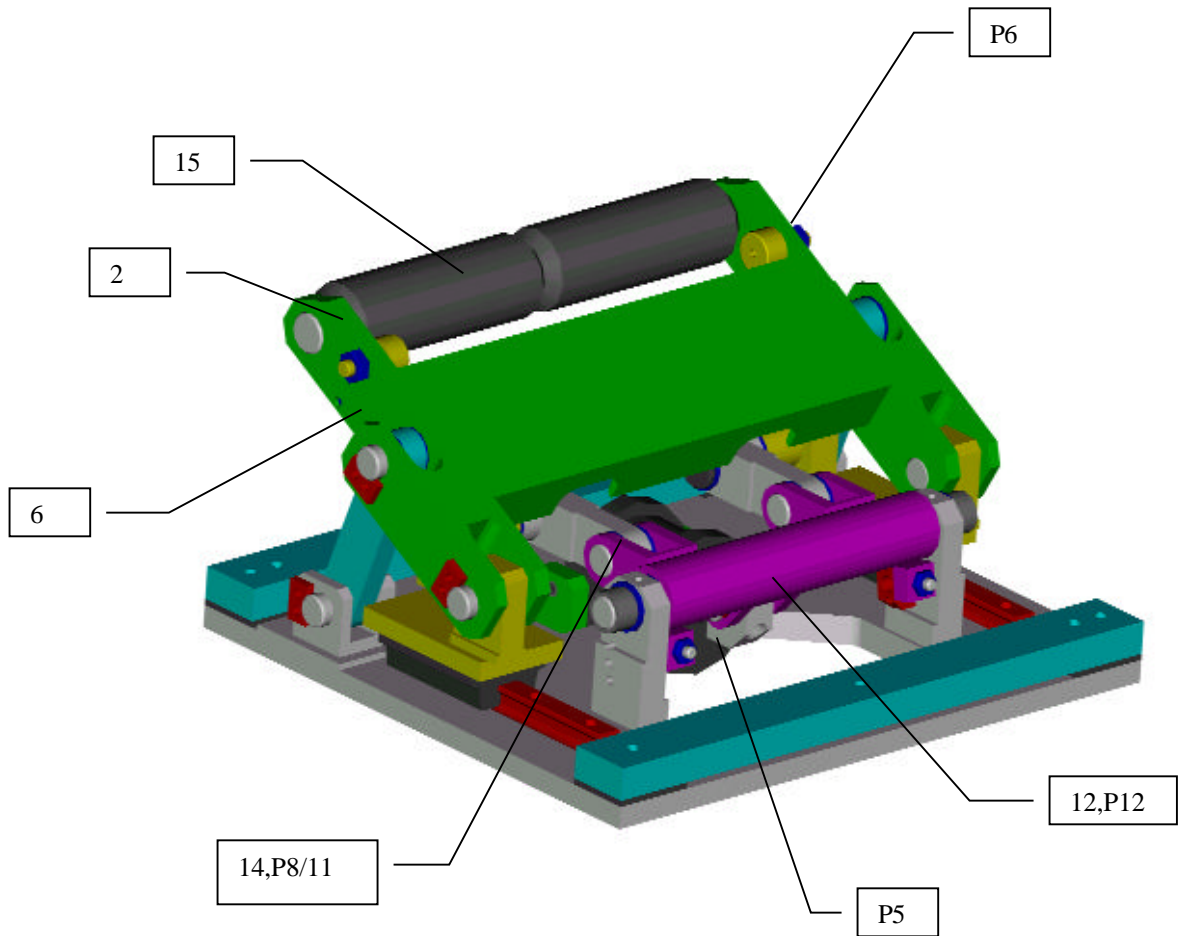

Figure 4. Partial Assembly (Up Position) – Isometric View

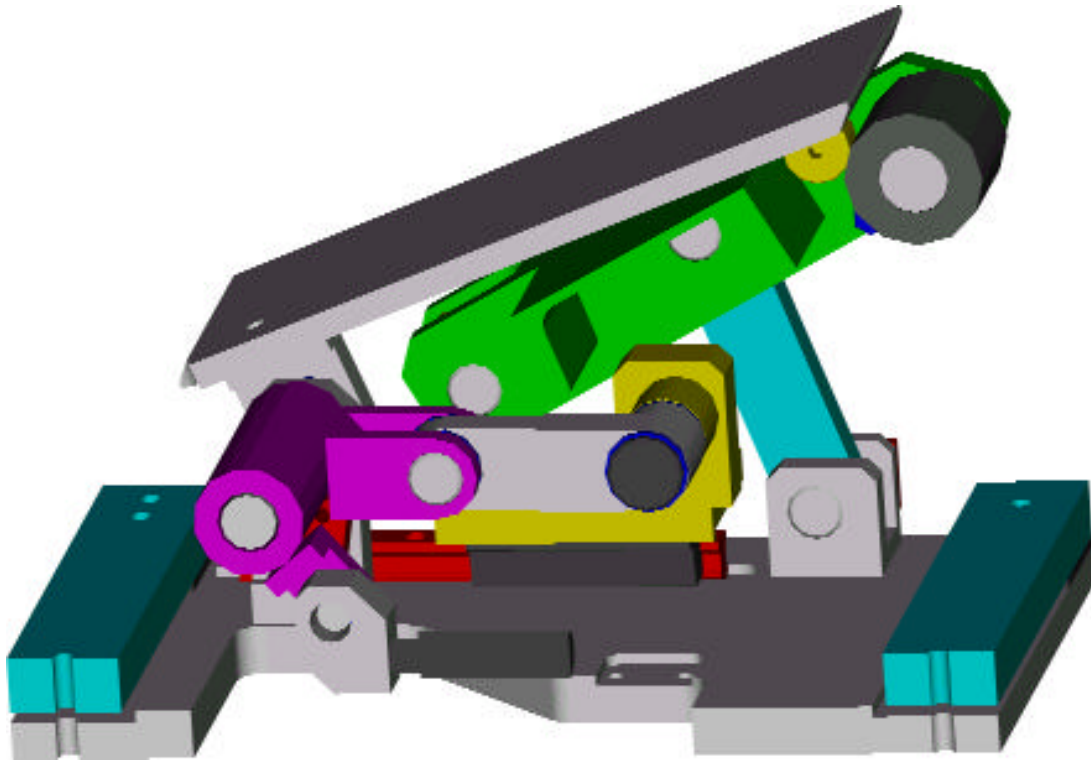

Figure 5. Wheel Stop (Up Position) – Section View Through the Centerline of the Air Cylinder