

# **Effective Use of Experimentation and Finite Element Analysis in a Vibrations Course**

**John R. Baker**  
**Department of Mechanical Engineering**  
**University of Kentucky**

## Abstract

It is a challenge for many students to firmly grasp the relationships between calculated results from textbook equations for multi degree of freedom structural vibration and actual behavior of a structure. While students can easily perform the calculations, they often do not fully understand how the theoretical results relate to behavior of an actual system. Experimentation is often included in courses to help bridge the gap between theory and actual system behavior. This paper outlines an approach that seems to be effective which combines experimentation, including use of smart materials, with the high-level graphics and animation capabilities available in a commercial finite element (FE) code, ANSYS.

Initial experimentation involves a simple structure, then structures with increasing levels of complexity are considered. The first system involves flexible springs and standard laboratory masses. Students set initial conditions by displacing masses by hand to produce motion dominated by one of two modes. Natural frequencies are determined using a stopwatch and counting oscillations. The results agree well with calculations based on theory for the lumped mass system. The simple system is also modeled in ANSYS, the natural frequencies are calculated, and the mode shapes are animated. The second experiment involves cantilevered beams. One thin, flexible beam includes piezoelectric patches, mounted such that an applied voltage produces a moment. Natural frequencies are determined experimentally from impact tests. Natural frequencies are also calculated from partial differential equation solutions and FE analysis. The mode shapes are animated in ANSYS. The beam is then excited with a sinusoidal voltage. The displacement pattern for vibration response due to excitation at either of the first two natural frequencies can be easily detected visually, and clearly agrees with theory and animated mode shapes from ANSYS. By varying the excitation frequency, the concept of large amplitude response for excitation near resonance is clearly demonstrated. A final experiment involves test and analysis of a compressor stator vane, for which a theoretical solution is not available.

The overall approach seems to provide the students with a good foundation in theory, basic modal testing techniques, practical application of a widely used commercial finite element code, and also a brief introduction to smart materials (PZT).

## I. Introduction

The study of mechanical vibrations is a standard component of a typical undergraduate mechanical engineering curriculum. At the University of Kentucky, vibration basics are included in a required systems modeling course, and some of the concepts are also applied in a required controls course. There is an additional course which is specific to the study of vibrations, ME-513: “Mechanical Vibrations”, which can be taken as an elective by upper level undergraduates, or for graduate credit. It has been taught at the University of Kentucky Extended Campus Program<sup>(1)</sup> every fall semester since Fall, 2001, as an undergraduate-only elective.

It seems that vibrations, in particular, is a topic that requires some hands-on laboratory experience by the students to grasp the concepts discussed in a textbook. Also, it seems appropriate for students in a vibrations course to gain at least some exposure to modern computer-based vibration tools, such as finite element analysis (FEA) software, like ANSYS. Vibrations instructors often include tests and demos in their courses, as described, for instance, in (2-7). Hagigat<sup>8</sup> provides a thorough overview of the types of vibration analysis that can be performed using ANSYS which can be included in a vibrations course.

A primary benefit of students performing experimentation and finite element analysis related to vibrations, along with calculating standard textbook analytical solutions, is that it gives the students an understanding of the need for, and methods available for, verification of their analysis results, so they can have confidence in their results. By the time students take a 500-level elective, such as Mechanical Vibrations, they already have an appreciation for the complexity of many engineering analyses. Often, however, a typical engineering lecture course may focus almost exclusively on analytical solution methods. Students find early in the engineering education process that it can be difficult to complete a complicated analysis without any errors. The introduction of modal testing methods and the finite element analysis approach in a standard vibrations course can make the students aware of some additional techniques available to verify their solutions. They can gain an appreciation of the need, for instance, to verify a finite element model by comparing of finite element results to experimental results before they can have confidence in the finite element model for evaluating the effects of potential design changes. They can also use analytical solutions for a similar structure, such as a beam-like structure, to verify that finite element analysis and/or experimental results are reasonable.

In earlier work<sup>9</sup>, use of ANSYS in a vibrations course in ME-513 at the University of Kentucky was discussed in the context of applying FEA software to a range of courses. The discussion below expands greatly on the vibrations-related information in (9), and describes an overall approach which has evolved in ME-513 involving a combination of lecture material based on a standard textbook<sup>10</sup>, laboratory testing, and use of the ANSYS finite element software

package. The process involves moving from simple lumped spring-mass systems, to continuous systems (beams), for which there are closed-form solutions for natural frequencies, and finally to a slightly more complex system, a compressor stator vane, for which the system natural frequencies can only be obtained through modal testing or finite element analysis.

The course is primarily taught in a standard classroom and lecture format. The laboratory exercises and demos described below are used only to supplement lecture material.

## II. Spring-Mass Systems

Initial lab work is performed using extremely simple and inexpensive equipment. The materials required to perform the initial lab work involve two flexible springs, standard laboratory masses, a rod with holes (such as a simple, inexpensive piece of metal framing), a metal hook, and a stopwatch. The flexible springs, rod, and hook can be purchased at a typical hardware store. The two dof system is shown in Figure 1.

### A. Testing

During the lab exercise, students first configure a 1 DOF system using one of the springs. They hang various known masses from the spring and measure the deflection to deduce the spring constant and verify that the spring is linear. They repeat for the other spring. They also perform vibration tests on each single DOF system. The spring constants for both springs in the system, as configured in Figure 1, are about 75-80 N/m. So, for either spring, when the system is configured as a 1 DOF system with a 1 kg mass connected to the spring, the system natural frequency is about 1.4 Hz. A frequency this low can be easily verified experimentally by counting some number of oscillations while timing with a stop watch. The students obtain extremely good agreement between test and 1-DOF vibration theory for the one DOF cases.

When configured as a 2-DOF system, with a 1 kg mass at the bottom and a 0.5 kg mass between the two springs (as seen in Figure 1), the system has two dominant natural frequencies at about 0.9 Hz and 3 Hz. The students are instructed to calculate the natural frequencies and mode shapes from a mathematical model. Then, by considering the mode one mode shape, using trial and error, they alter initial displacements (imposed by hand) until they are able to see free motion heavily dominated mode 1. Using a stop watch, and counting oscillations, they are able to verify that the mode one natural frequency in the tests agrees closely with that obtained using the standard method of solving the eigenvalue problem from a two DOF lumped mass mathematical model. They then repeat the test, but alter the initial displacements of the masses, again by hand, until they see free motion dominated by mode 2. It is more difficult to accurately count the smaller amplitude, higher frequency oscillations (which are about 3 Hz) corresponding to mode 2 motion, but error of less than 10% between calculated natural frequency and test natural frequency for mode 2 is easily attainable with this simple system.

At a later date, the students return to the lab to do modal testing on a cantilevered steel beam, as discussed below. The beam tests follow classroom discussions of Fast Fourier Transforms, and use of accelerometers to measure high frequency motion. At this time, before testing the beam, an accelerometer is placed on one of the masses in the two DOF configuration. They view time history accelerometer voltage data, and a corresponding FFT of this data, with various initial displacements applied to the two masses. This serves to verify information from the class that the motion, in general, for the 2 DOF system involves participation of both modes. Also, because it is easier to conceptualize low frequency motion involving basically only two modes, as compared to motion involving many high frequency modes, consideration of the accelerometer time history and corresponding FFT for the 2 DOF system seems helpful in understanding results from subsequent beam testing.

Figure 2 shows a screen capture from the data acquisition unit for the two DOF tests with an accelerometer mounted on one of the masses. At left, in both the top and bottom plots, is the time history, and at right is an FFT of the time domain data. The top plots are for a case when the initial displacements were set so that mode 2 motion was highly dominant, and the bottom plots are for a case where general initial conditions were used, and both modes clearly participate. (The frequency range in the FFT's is not the same for both cases.)

## B. Finite Element Analysis

The students are provided an ANSYS macro, which creates a 3D representation of the 2 DOF spring mass system. They only need to input spring constants and mass values, and the macro automatically calculates the natural frequencies and mode shapes. They are given instructions on how to animate the mode shapes on the screen. A plot of the deflected shape for mode 2 is shown in Figure 3. Excellent agreement is obtained between test results and FEA results, and the ANSYS analysis of this simple system serves as an introduction to FEA as a vibration analysis tool. The modeling method incorporated is not the most efficient for this simple system. It would be more logical to use lumped mass finite elements. But, 3D solid elements (ANSYS Solid45 elements) are used to model the masses in order to provide for better visualization of the system motion when the mode shapes were animated. The springs are modeled with standard ANSYS spring-damper elements (Combin14 elements). There is some explanation provided in class related to alternative finite elements available in ANSYS, such as lumped mass elements. As described in Section V, they are required to take a class specific to finite element analysis before graduation. So, even if they have not taken a finite element class before this vibrations class, they do gain a solid background on FEA before they become practicing engineers.

## III. Beams

Chapter 9 in the course textbook<sup>10</sup> provides partial differential equation solutions for simple geometries of continuous systems. The students study the cantilevered beam

solution, and calculate natural frequencies for the thin, flexible aluminum beam and the small steel beam shown in Figure 4, assuming they are clamped in a vice.

#### A. Testing

Standard impact tests, using a hammer and accelerometer, are performed on both beams in Figure 4. Very good agreement is achieved with the textbook solution for natural frequencies based on partial differential equations, and the test results for both structures. The impact test results for the steel beam are shown in Figure 5, where transfer functions based on two different hammer impact locations are shown. In the case on left, both the accelerometer at hammer impact were near the free end of the beam. In the case on the right, the hammer impact was near the location of the mode 2 node line, as determined from finite element analysis and the partial differential equation solution. With the hammer impact near the mode 2 node line, there is little mode 2 response shown in the transfer function at right in Figure 5.

To illustrate the concept of forced harmonic response, a sinusoidal voltage is applied to the PZT on the aluminum beam using a function generator to create a sinusoidal moment near the clamped end. First, a frequency well below the first mode resonance of about 7 Hz is applied, and there is no perceptible motion. The frequency is adjusted until a very large amplitude motion, corresponding to the standard cantilevered beam mode 1 mode shape, is easily detected visually. The frequency is then increased above the mode 1 resonance, and the motion dies until there is no perceptible motion of the beam. The frequency is then increased to approximately the mode 2 natural frequency of about 42 Hz, and again, the motion amplitude is large enough to detect visually. Close visual inspection reveals the mode 2 node line, as there is clearly a location on the beam with no motion when it is excited at its mode 2 natural frequency.

#### B. Finite Element Analysis

The students are provided a simple ANSYS macro, and they use it to calculate the natural frequencies of the cantilevered beams described above. Figure 6 shows a listing of the macro, which requires input of the beam width,  $B$ , height,  $H$ , length,  $L$ , modulus,  $E$ , and density,  $\rho$ . Excellent agreement is obtained between test natural frequencies and finite element analysis for the two beams tested, and the animation of the mode shapes serves to reinforce the findings in the lab. The first three mode shapes found through the FEA are the well known beam bending mode shapes.

### IV. Compressor Stator Vane

The final structure considered is a relatively simple flat plate compressor stator vane, shown in Figure 7. While it is not a highly complex geometry, it serves to verify that some structures cannot be analyzed with closed-form textbook solutions.

## A. Finite Element Analysis

The students are given an ANSYS macro to model the structure, and they each execute it to calculate natural frequencies and animate the mode shapes, in preparation for a lab demo in which impact tests are performed on the vane. The model is produced using ANSYS Solid95 3D solid finite elements. The mode shapes of the stator vane from the ANSYS macro are shown in Figure 8. Mode 1 is at left, with a frequency of 224 Hz, and mode 2 is at right, with a frequency of 463 Hz.

## B. Testing

The vane is clamped in the vice and impact tests are performed. Results for the first two natural frequencies are in reasonable agreement with FEA results (within 10%). This is a good demonstration of a situation in which real-life boundary conditions can't be easily duplicated in a finite element model, as the vane cannot be perfectly clamped in the vice. Also, in the impact tests, the mode 2 node line determined through the finite element analysis (the blue region in Figure 8 – at right) is verified. By impacting the vane away from this line, a significant mode 2 peak is evident in the transfer function. But, impact in the blue region produces only a very small mode 2 peak.

## V. Opportunities for Expansion of the Approach

The approach outlined above seems to have benefit in introducing students to system analysis methods that can be used to verify analytical solutions, or to determine vibration characteristics for systems for which an analytical solution would be difficult, if not impossible, to obtain.

Time constraints in the course prevent adding much related to finite element background. The students do take a required course specific to finite element analysis prior to graduation. However, it is not a prerequisite for the vibrations course. Because they will complete a finite element course, however, before they become practicing engineers, they will develop an understanding of the approximations and limitations inherent in finite element modeling. Also, they will be introduced to alternative types of finite elements. Although there is not much additional time available in this course to expand on the background of the finite element method as a technique for vibration analysis, it may be advantageous in future offerings of the course to give the students some exercise in which a finite element analysis on a structure is carried out with at least two different types of elements. For instance, a beam could be modeled with 2D beam elements, and also with 3D solid elements.

Because the continuous system experimentation carried out in the class currently involves bending vibration, if time permits, at least one additional system type will be studied experimentally in the next course offering. One possibility would be measurement of torsional vibration of a shaft. An additional study that could also be useful would be testing of a short, wide beam to illustrate that Euler beam theory is less accurate for such cases,

and an alternative theory, or finite element analysis, may be necessary to attain accurate results for vibration of such systems.

## VI. Summary and Conclusions

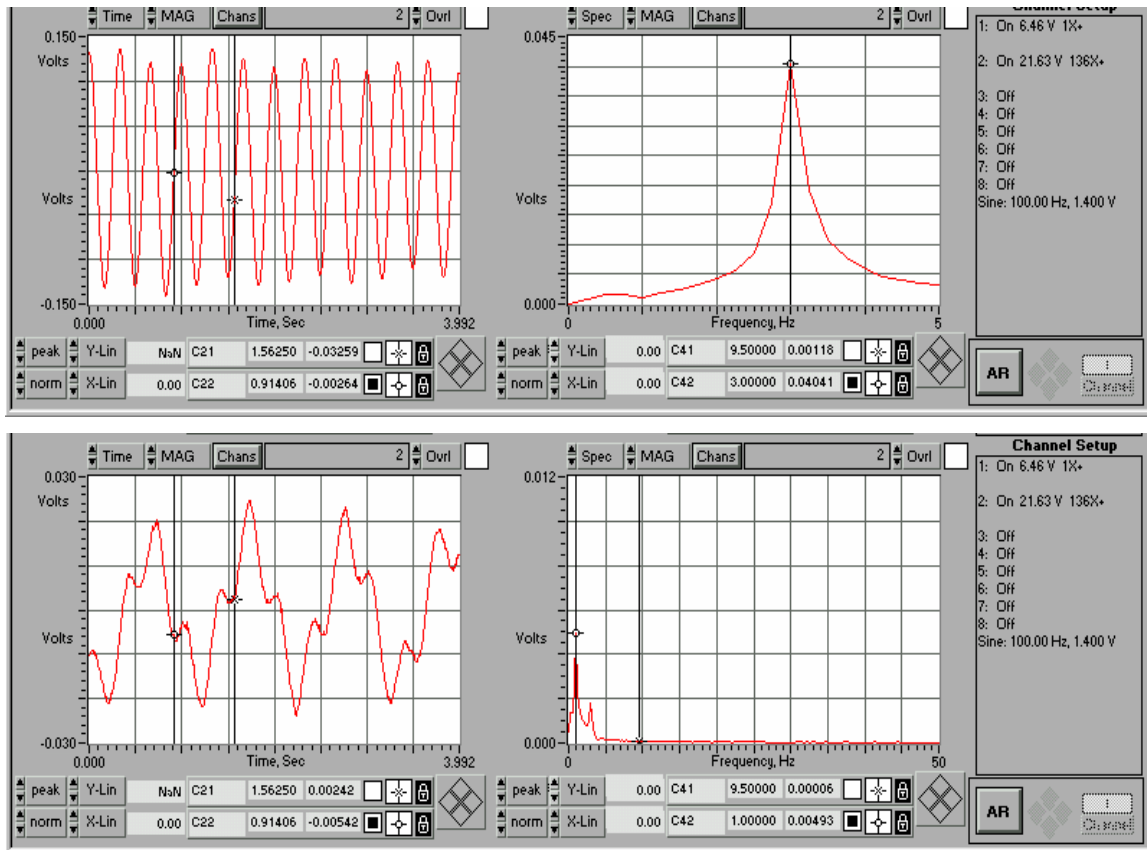
An overview has been provided for a series of exercises, including lab work and finite element analysis, which are included in a vibrations course at the University of Kentucky Extended Campus Program in Paducah, KY. The overall approach, moving from simple systems to more complex, seems to be effective in supplementing lecture material. Student feedback has indicated that they believe the hands-on testing experience, coupled with use of the finite element software (in particular the mode shape animation capabilities of the software), is an effective aid in understanding basic structural vibration.

A primary benefit of the approach is that it gives students an understanding of methods that are available to verify the results of an engineering analysis. For instance, experimentation can be used to verify a finite element analysis solution. The finite element model can then be used with confidence to evaluate the expected impact on vibration characteristics of possible design changes.

Due to time limitations in the course, it would be difficult to add much additional work related to the topics outlined in this paper. However, in future offerings of the course, some additional work related to comparison of alternative finite element models would seem to be beneficial. Also, additional testing work related to another type of system, perhaps a torsional vibration system, would also likely be beneficial if added.



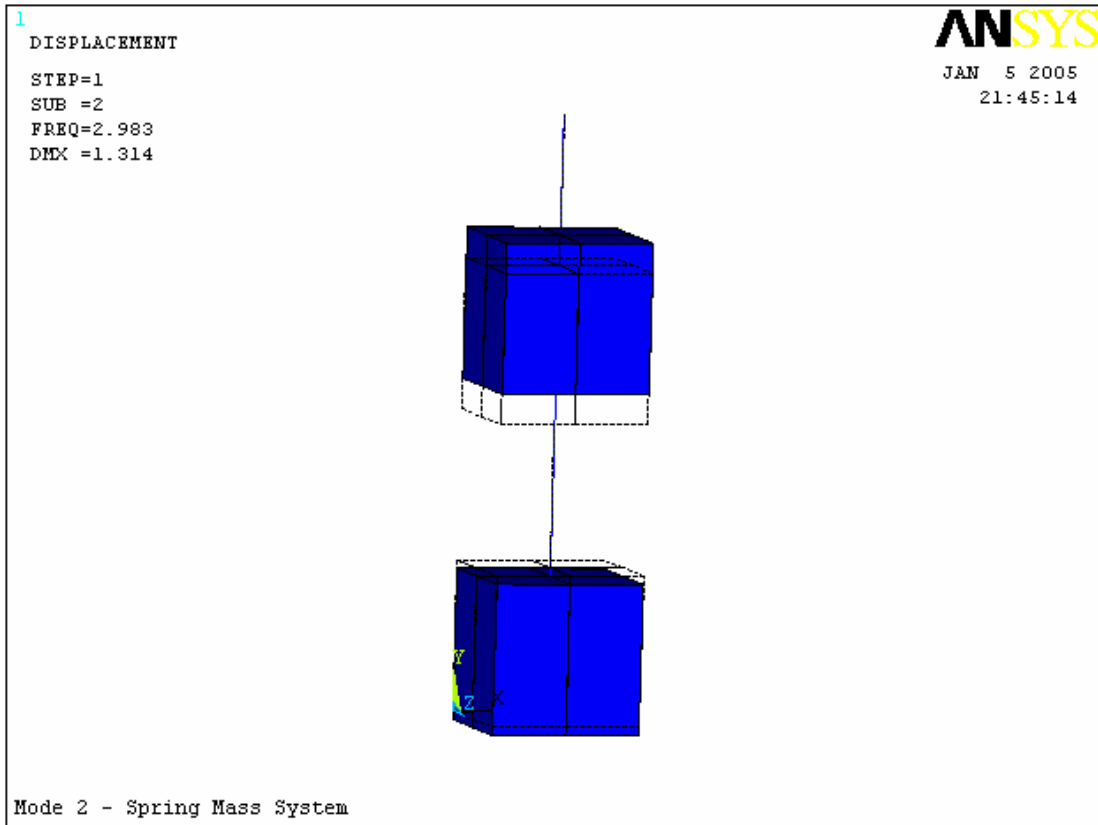
**Figure 1:** Two DOF spring mass system.



**Figure 2:** Screen captures from accelerometer signal from Two DOF spring-mass system free response.

*Proceedings of the 2005 American Society for Engineering Education Annual Conference & Exposition Copyright © 2005, American Society for Engineering Education*

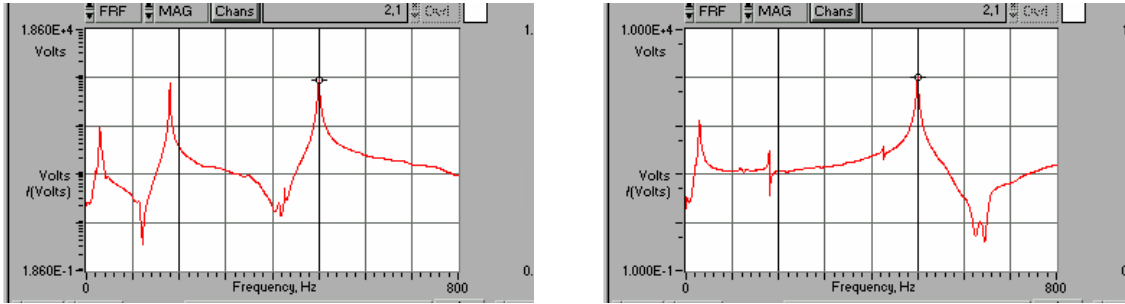




**Figure 3:** Mode two mode shape plotted in ANSYS from the 3D model of the spring-mass system created using the macro provided to the students.



**Figure 4:** Thin aluminum beam, with mounted PZT (left), and small steel beam (right).



**Figure 5:** Screen captures of transfer functions from modal tests on the cantilvered steel beam. The hammer impact location was near the mode 2 node line in the plot at right.

```

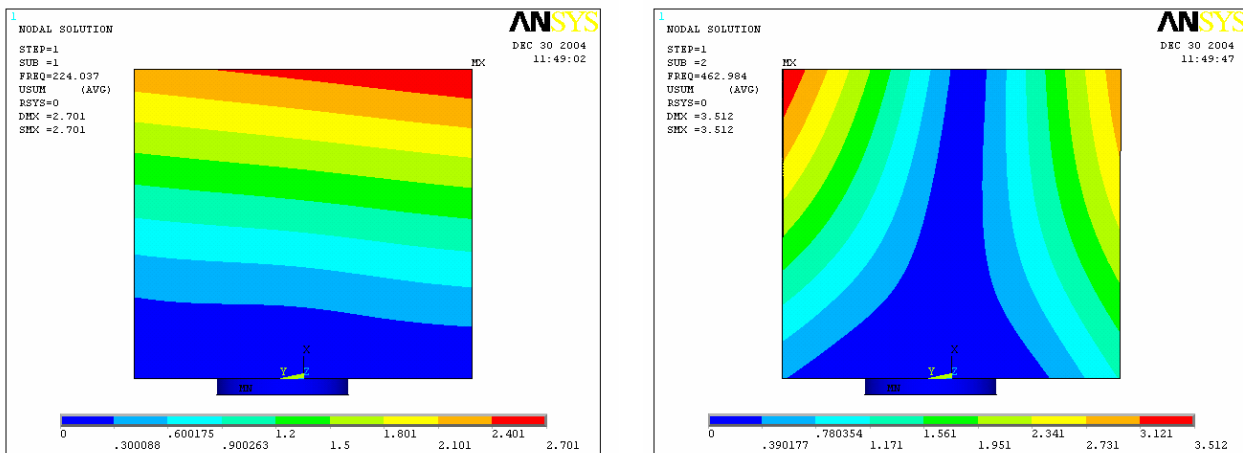
b=arg1
h=arg2
L=arg3
e=arg4
rho=arg5
/prep7
a=b*h
i=(1/12)*b*(h**3)
et,1,3
ex,1,e
dens,1,rho
prxy,1,.3
r,1,a,i,h
n,1,0,
n,100,L
fill
e,1,2
*repeat,99,1,1
/solu
antype,modal
modopt,lanb,5,0,50000
d,1,all
solve

```

**Figure 6:** Input listing for an ANSYS macro that calculates the first five frequencies of a cantilevered beam.



**Figure 7:** Steel, flat-plate stator vane.



**Figure 8:** Mode shapes of the stator vane from the ANSYS macro. Mode 1 is at left, with a frequency of 224 Hz, and mode 2 is at right, with a frequency of 463 Hz.

## VII. References

<sup>1</sup>Capece, V.R., Murphy, W., Lineberry, G.T., and Lykins, B., “Development of an Extended Campus Mechanical Engineering Program”, Proceedings of the *2000 ASEE Annual Conference & Exposition*, American Society for Engineering Education, (2000).

<sup>2</sup>Pardue, S., and Darvennes, C., “A Modular Approach to Vibrations”, Proceedings of the *2001 ASEE Annual Conference & Exposition*, American Society for Engineering Education, (2001).

<sup>3</sup>Murphy, K., and Orabi, I., “Structural Response in the Frequency Domain Using Labview”, Proceedings of the *2001 ASEE Annual Conference & Exposition*, American Society for Engineering Education, (2001).

<sup>4</sup>D’Souza, S., Scott, N.W., and Stone, B.J., “A Student Controlled Two-Degree of Freedom Vibration Laboratory”, Proceedings of the *1998 ASEE Annual Conference & Exposition*, American Society for Engineering Education, (1998).

<sup>5</sup>Kukreti, A., “Use of a Small-Scale Models Testing Laboratory to Teach Structural Dynamics”, Proceedings of the *1999 ASEE Annual Conference & Exposition*, American Society for Engineering Education, (1999).

<sup>6</sup>Bilal, N., Kess, H., and Adams, D., “Development of a Roving Laboratory in Vibrations for Undergraduate Engineering Students”, Proceedings of the *2003 ASEE Annual Conference & Exposition*, American Society for Engineering Education, (2003).

<sup>7</sup>Kiritsis, N., Huang, Y., and Ayrapetyan, D., “A Multi-Purpose Vibration Experiment Using Labview”, Proceedings of the *2003 ASEE Annual Conference & Exposition*, American Society for Engineering Education, (2003).

<sup>8</sup>Hagigat, C., “Using Finite Element Software for Enhancing a Vibration Analysis Curriculum”, Proceedings of the *2004 ASEE Annual Conference & Exposition*, American Society for Engineering Education, (2004).

<sup>9</sup>Baker, J., Capece, V., and Lee, R., “Integration of Finite Element Software in Undergraduate Engineering Courses”, *Computers in Education Journal*, Vol. XII, No. 2, pp. 10-19, (2002).

<sup>10</sup>Thomson, W., and Dahleh, M., *Theory of Vibration with Applications, Fifth Edition*, Prentice-Hall, Upper Saddle River, NJ (1993).

### JOHN R. BAKER

John R. Baker is an Assistant Professor of Mechanical Engineering at the University of Kentucky Extended Campus Program in Paducah, KY. He received his B.S., M.S., and Ph.D. in Mechanical Engineering from the University of Kentucky in Lexington, KY. After obtaining his B.S., he spent three years working in the Plastics Division of Eastman Chemical Products, Inc. He entered his current position in July 2000.

*“Proceedings of the 2005 American Society for Engineering Education Annual Conference & Exposition Copyright © 2005, American Society for Engineering Education”*