AC 2012-3218: ELICITING STUDENTS' INTERPRETATIONS OF ENGINEERING REPRESENTATIONS

Dr. Adam R. Carberry, Arizona State University

Adam R. Carberry is an Assistant Professor in the College of Technology and Innovation, Department of Engineering at Arizona State University. He earned a B.S. in materials science engineering from Alfred University, and received his M.S. and Ph.D., both from Tufts University, in chemistry and engineering education respectively. His research interests include student conceptions, engineering epistemological beliefs, self-efficacy, and service-learning.

Dr. Ann F. McKenna, Arizona State University, Polytechnic

Ann F. McKenna is Chair of the Department of Engineering and the Department of Engineering Technology in the College of Technology and Innovation at Arizona State University (ASU). Prior to joining ASU as an Associate Professor of engineering, she served as a Program Officer at the National Science Foundation in the Division of Undergraduate Education, and was on the faculty in the Department of Mechanical Engineering and Segal Design Institute at Northwestern University. McKenna's research focuses on understanding the cognitive and social processes of design, design teaching and learning, the role of adaptive expertise in design and innovation, the impact and diffusion of education innovations, and teaching approaches of engineering faculty. McKenna received her B.S. and M.S. degrees in mechanical engineering from Drexel University and Ph.D. from the University of California, Berkeley. McKenna also serves as an Associate Editor for the Journal of Engineering Education.

Dr. Odesma Onika Dalrymple, Arizona State University, Polytechnic

Eliciting Students' Interpretations of Engineering Representations

Abstract

Understanding what students truly learn is contingent on choosing an assessment method that affords students with the opportunity to fully express what they know. Allowing students to represent their ideas using questions open to multiple representational responses provides them with a choice. This choice can be used to highlight the students' own personal learning styles, so that the instructor gains a better understanding of what the student has learned. This study found that questions written to openly accept multiple representations lead to a higher student use of alternatives to written description, which is commonly the default form of assessment chosen by most engineering instructors.

Introduction

Assessing what students have truly learned from an intervention can be quite challenging. The challenge is compounded in a multidisciplinary course because favored methods vary across the disciplines. Some methods, like homework and exams, are pervasive throughout most curricula; other less common methods such as demonstrations, discussions, observations, and interviews supply choice in what methods are most appropriate for multidisciplinary classrooms.

Underlying all assessment methods is the presentation of the assessment. Presenting a question or task to students determines not only the content of their answer, but also the means by which they can answer the question. The framing of a question can maximize or constrain the form or representation of the response. Of the utmost importance is the ability of an assessment to allow a student to respond in a way that demonstrates their knowledge. Students may prefer, or be more comfortable using different types of representations, ranging from written descriptions to illustrations to physical constructions. Therefore, it is essential that an assessment afford students with multiple representational options. A restricted question may not provide a true assessment of every student's understanding of the intended context.

The following study investigates this phenomenon through an investigation of student interpretations and the representations they use to answer similarly purposed questions. Two questions asking essentially the same query were presented to students. The intended difference in wording of the two questions was to invite students to respond using various forms of representation (written descriptions, drawings, flow charts, etc.) to conclude that a DC voltage measurement function works.

Literature Review

Student learning and assessment are inextricably linked (Hargreaves, 1997). Learning is the basis for what we strive to assess. We assess learning because it is a crucial evaluation that helps instructors and learners to actively monitor learning progress (Bransford, Brown, & Cocking, 1999). Assessment is needed to improve learning, increase teaching effectiveness, and provide a quality-learning environment (Gardiner, 1997). Classroom assessment should therefore be

learner-centered, teacher-directed, mutually beneficial, formative, context-specific, on going and rooted in good teaching practice (Angelo & Cross, 1993).

An ideal student-centered assessment offers students the opportunity to use preferred forms of representations. There are many varieties of representations including words, diagrams, equations, and sketches. Multiple representations have been used and studied in engineering to tackle problem-framing (McKenna & Agogino, 2004; Triplette, Kelly, and Krause, 2011; Watkins, Hall, Chandrashekhara, & Baker, 2004) and problem-solving (Jonassen, Strobel, & Beng Lee, 2006).

Engineering-based multidisciplinary courses present a valuable environment to assess students' use of multiple representations. For example, students learn how to develop purposeful representations of engineering concepts and solutions through their strategic use of models. Understanding student conceptions of modeling techniques (McKenna & Carberry, 2012) is important to understanding how students use multiple representations. A solid understanding of representational preference and the available forms of representations are essential in the education of a student and the assessment of their learning. Neglecting student preferences to use multiple representations is both a disservice to their learning and a detriment to their course grades.

Research Design

A class of sixty-four sophomore-level students was asked to participate in the research study. These students are enrolled in a unique multidisciplinary engineering program offering a Bachelors of Science in Engineering degree. Students may direct their area of study after their sophomore year in one of four focus areas – robotics, mechanical engineering systems, electrical engineering systems, and civil engineering (land development). Every student, regardless of focus area, must complete a project-based course each semester of his or her degree. The cohort of students was mostly male (91%) with a high percentage of non-traditional students (28%) returning to school.

For the study, students were asked during their required engineering project course, to represent their understanding of how the DC voltage measurement function (Figure 1) works in a multimeter that they assembled. Students were first asked to submit for homework their response to the following question:

Q1: Describe how the DC voltage measurement function works.

In the follow-up class, students were then asked to respond to the following question:

Q2: What evidence would you present to convince someone that the DC voltage measurement works?

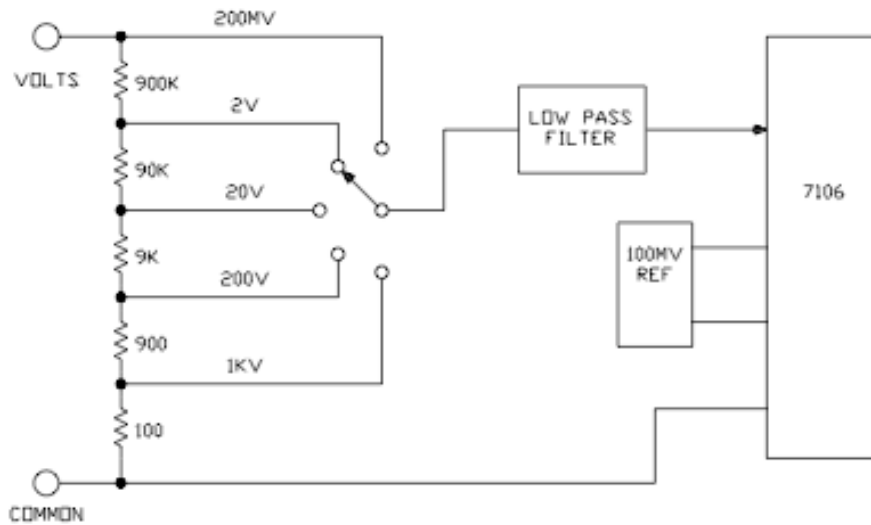

Figure 1: Simplified DC voltage measurement diagram for the Model M-10005 Digital Multimeter Kit, Elenco Electronics, Inc.

Both questions were designed to assess how well students understand the DC voltage measurement function of their multimeter with a focus on understanding how students represent that understanding, *i.e.*, descriptions, drawings, or mathematical equations. Question 1 represents our version of the typical question presented to students. Students are asked directly to *describe* how something works, which automatically triggers them to respond with a written description. Question 2 represents an alternative approach using terms like *evidence*, *present*, and *convince*. The formulation of the question allows for an open-interpretation of how the student can answer the question. Responses were collected from the two assignments and analyzed to identify if the changes in wording caused students to respond and interpret the questions differently.

Data Analysis & Results

The written student responses were analyzed using an open-coding approach to identify emergent categories in the data. A single rater first read each student's response to determine a set of categories compiled into a rubric. The rubric was then used to code each student's responses. A second rater then used the rubric to test its validity using a two-step process: 1) coding 10% of the responses using the rubric, and 2) consulting the first rater's codes. The process was repeated until 100% inter-rater reliability was reached between the two raters.

Four codes of interest emerged from the data: 1) explain (broken into technical descriptions and explain), 2) use a demonstration or experiment, 3) mathematically represent, and 4) present an illustration (See Table 1 for examples). The number of students referring to each category is displayed in Figure 2. Responses were coded by assigning a value of one when a code was present and zero if a code was not.

Table 1: Examples of each code.

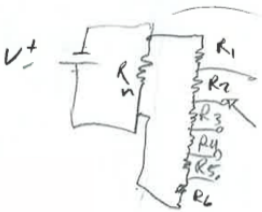
Category	Example
Technical Descriptions	“The voltage that is input is sent through a series of resistors designed to reduce the input voltage to a level that the chip can process...”
Explain	“You would first have to explain to them how it works.”
Use a Demonstration or Experiment	“I would probably do a demonstration with the device to show it does read”
Mathematically Represent	$V = IR$
Present an Illustration	

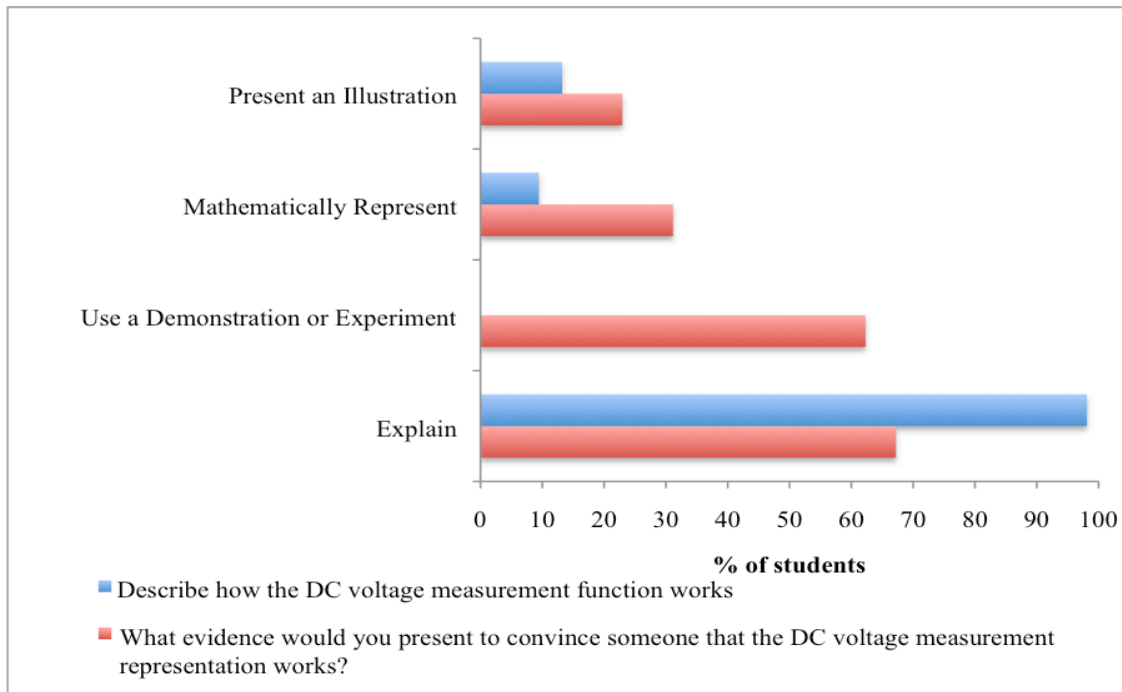

Figure 2: Summary of student responses.

The *Explain* category referred to instances when students wrote technical descriptions or identified verbal explanations as their method of conveying how the DC voltage measurement works. This category warranted being broken down into two sub-categories to provide a more refined analysis of how students phrased their “explain” responses (Figure 3). As was seen in Table 1, the major difference between these two sub-categories was that technical descriptions provided actual descriptions of how the DC voltage measurement works, while explain represented students simply stating that they would provide a technical description. The responses from Question 1 demonstrate a tendency to use written text-based explanations,

specifically technical descriptions. The remaining categories were not broken down into sub-categories as this additional step was unnecessary to differentiate responses. The *Use a Demonstration or Experiment* code represents when students expressed using a visual display to clarify the DC voltage measurement. The framing of Question 1 did not elicit this type of response, but the framing of Question 2 resulted in a substantial increase in this category. The *Mathematically Represent* category paid close attention to students' use of mathematical representations as a way to show how the DC voltage measurement works. For both versions of the question, very few student responses included aspects of mathematical representations. Finally, the *Present an Illustration* category included instances when students used drawings, flow charts, and other illustrations to answer the questions.

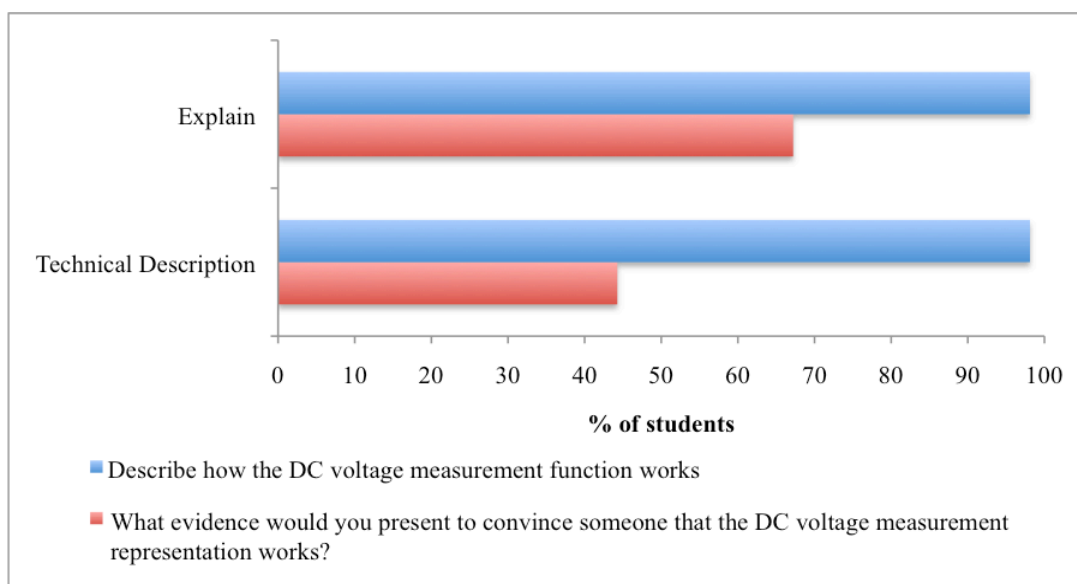

Figure 3: Context of explanation category.

A paired-samples t-test was conducted to compare the responses between each question. A significant difference in the number of students citing Explain, technical Descriptions, Use a Demonstration or Experiment, and Represent Mathematically was seen (Table 2). Each category was seen more frequently for Question 2, except Technical Descriptions, which dominated Question 1 responses. Only Illustrations remained consistently referred to between Question 1 and 2. These results show that the wording of Question 2 elicited different representational responses from the students.

Table 2: Paired-samples t-test results.

Category	<i>t</i> (50)
Explain	-11.495***
Technical Descriptions	6.704***
Use a Demonstration or Experiment	-9.177***
Represent Mathematically	-3.125**
Illustrations	-1.071

*** $p \leq 0.001$; * $p \leq 0.01$

Discussion and Implications

A comparative analysis of the overall class responses indicated that most students provide equivalent responses to the two questions in terms of technical competency, i.e. their understanding of how the DC voltage measurement technically works. The difference between the responses was the students' chosen method of representation. The wording of Question 2 seemed to elicit a broader range of responses other than just written descriptions. The result was not a more technically correct answer, but responses that were more inclusive of representations used in typical engineering communication such as equations, flow charts, etc. One limitation of this study is that students did not describe the type of evidence they would actually provide. Students may not know how to provide evidence for the various forms suggested. They may feel that the methods are best, but in reality they may not be able to.

The overall findings suggest that assessment in multidisciplinary engineering courses should offer students opportunities to represent their understanding using multiple representations. Limiting the ways in which a student can respond limits not only the student response, but also the instructor's sense of how well a student truly understands the content. Future considerations should be made to present students with more open-ended questions accompanied by learning objectives that key into teaching students how to model using various representations.

Conclusions and Future Work

This study explores and compares the differences between student responses when they are asked to *describe* how something works and when they are asked to provide *evidence to convince someone* that something works. The intended purpose of the study was to gain some insights into the use of multiple representations in a multidisciplinary engineering course. The results have shown that assessment of student learning should include questions that offer students the ability to represent their understanding in multiple ways. The results of this study are intended to assist faculty in appropriately assessing student learning and to provide a vehicle for introducing effective use of representations, specifically models, to describe how something works.

Acknowledgement

This material is based upon work supported by the National Science Foundation under Grant No. 0648316. Any opinions, findings, and conclusions or recommendations expressed in this material are those of the author(s) and do not necessarily reflect the views of the National Science Foundation.

Bibliography

- Angelo, T. A. & Cross, K.P. (1993). *Classroom assessment techniques: A handbook for college teachers*. San Francisco, CA: Jossey-Bass.
- Bransford, J. D., Brown, A. L., & Cocking, R. R. (2000). *How people learn*. Washington, D.C.: National Academy Press.

- Hargreaves, D.J. (1997). Student learning and assessment are inextricably linked. *European Journal of Engineering Education*. 22 (4), 401-409.
- Gardiner, L.F. (1997) Redesigning higher education: producing dramatic gains in student learning, *ASHE-ERIC Higher Education Reports*, 23 (7), Washington, DC: Association for the Study of Higher Education.
- Gardner, H. (1983) *Frames of Mind: The theory of multiple intelligences*, New York: Basic Books.
- Jonassen, D., Strobel, J., & Beng Lee, C. (2006). Everyday problem solving in engineering: Lessons for engineering educators. *Journal of Engineering Education*, 95 (2), 139-151.
- McKenna, A. F., & Agogino, A.M. (2004). Supporting mechanical reasoning with a representational-rich learning environment. *Journal of Engineering Education*, 93 (2), 97-104.
- McKenna, A.F. & Carberry, A.R. (2012). Characterizing the role of modeling in innovation. *International Journal of Engineering Education*, 28(2).
- Simon, H.A. (1977). *Models of discovery and other topics in the methods of science*. Dordrecht: Reidel.
- Triplett, J., Kelly, J. E., & Krause, S.J. (2011). Development and use of concept context maps to promote student conceptual understanding in an introductory materials course. *American Society for Engineering Education Annual Conference & Exhibition*, Vancouver, BC, Canada. AC 2011-2449.
- Watkins, S.E., Hall, R.H., Chandrashekhara, K., & Baker, J.M. (2004). Interdisciplinary learning through a connected classroom. *International Journal of Engineering Education*. 20(2), 176-187.