

Engagement in Practice: An Engineering Service-Learning Course in Collaboration with an ART 2D Design Course to Serve Young People on the Autism Spectrum Using the Touchboard

Dr. Yanjun Yan, Western Carolina University

Yanjun Yan received her B.S. and M.S. degrees in Electrical Engineering from Harbin Institute of Technology (China), and the M.S. degree in Applied Statistics and the Ph.D. degree in Electrical Engineering from Syracuse University. She is an assistant professor in engineering and technology at Western Carolina University. Her research interests are statistical signal processing, diagnostics, and particle swarm optimization.

Prof. Mary Anna LaFratta, Western Carolina University

Mary Anna LaFratta is an artist, designer and design and arts educator in graphic design in the School of Art and Design at Western Carolina University. She has worked with students and faculty in multidisciplinary and multimodal projects for more than twenty years. She has participated in projects funded by the National Endowment for the Arts, the National Art Education Foundation, and the National Science Foundation. Recently, her graphic design students worked in collaboration with the School of Music and the National Nanotechnology Initiative in making short animations to explain various aspects of nanotechnology, and designing and developing non-digital games for learning, reading and speaking Cherokee focused on its use of pronouns while partnering design students with faculty and students in the Cherokee Language program and the Eastern Band of the Cherokee Indians in western North Carolina. Both the nanotechnology animations and the Cherokee word games has been distributed to large and multifaceted audiences nationally.

Dr. Hugh Jack P.E., Western Carolina University

Dr. Jack is the Cass Ballenger Distinguished Professor of Engineering and Department Head of the School of Engineering and Technology within Western Carolina University. His interests include robotics, automation, and product design.

Dr. Lane Graves Perry III, Western Carolina University

Lane Graves Perry, III (PhD, ME, MEd, BBA) currently serves as executive director of the Center for Community Engagement and Service Learning at Western Carolina University, a Carnegie Community Engaged campus. His research interests include community engagement/service-learning, global citizenship development, and public health.

Engagement in Practice (EIP): An Engineering Service-Learning Course in Collaboration with an ART 2D Design Course to Serve Young People on the Autism Spectrum Using the Touch Board™

This course is the first designated “Service-Learning Course” from the College of Engineering and Technology at Western Carolina University. The course is offered in the Spring semester (Jan-May) 2019 and is the first Service-Learning project between the School of Engineering + Technology and the School of Art and Design. The service-learning project involves interdisciplinary student teams consisting of upper-level engineering and technology students and entry-level art and design students working together to mentor young clients on the autism spectrum at a not-for-profit organization, Full Spectrum Farm (FSF), in the local community. The course will use Touch Boards (<https://www.bareconductive.com/shop/touch-board/>) manufactured by Bare Conductive Touch Boards are essentially Arduino boards with capacitive sensing capabilities (<https://www.arduino.cc/>) that are programmed with the Arduino IDE (Integrated Design Environment) for user-friendly interfaces. Commonly these boards are used with conductive paint that is applied with a brush to create an artistic drawing resulting in a circuit that reacts to human touch to trigger a user-specified sound or other actions. The team has created a sample design and used it at outreach activities, demonstrating that the Touch Boards will be manageable for new learners under our students’ mentoring. The authors met with the FSF clients in Summer 2018 and have hosted the clients on campus to work with our students three times in Spring 2019, with a few more meetings scheduled. The project will provide novel avenues of expression for the autistic clients and opportunities for the engineering and art students to learn to apply their discipline knowledge in real-world applications, practice collaboration, develop mentoring skills, critically reflect upon their learning, and integrate sound, technology and visual graphics into interactive two-dimensional compositions. For the FSF clients, it is an opportunity for them to work directly with university students on the university campus and to engage in experiential learning by making and designing a two-dimensional composition that extends the boundaries of traditional design and imagination. The initiation of this idea started more than two years ago and has been shaped by many discussions between the authors and one author’s participation in the WCU Faculty Institute of Community Engagement during the 2017-2018 academic year. The team has obtained about \$3500 of internal funds and \$1000 external funding to fully materialize this interdisciplinary Service-Learning project. This project will focus on 2D design, and hopefully lead to a future course on 3D interactive design.

Introduction

Research into the value and impact of service-learning as a pedagogical approach is robust. A meta-analysis of 62 studies engaging nearly 12,000 students found that those involved in service-learning experiences demonstrated significant gains in key outcome areas including academic performance as an indicator of learning, civic engagement and social skills, and attitudes towards self-worth and personal growth [1]. While there are nearly 200 working definitions of service-learning, the definition offered by Bringle and Hatcher [2] is the most encompassing and widely adopted. In this, service-learning is identified as a “course-based, credit bearing educational experience that allows students to (a) participate in an organized service activity that meets

identified community needs and (b) reflect on the service active in such a way as to gain further understanding of course content, a broader appreciation of the discipline, and an enhanced sense of civic responsibility (p. 112).” Clearly, it is key that the service efforts with the partner be reciprocal and mutually valued, connected and committed to advancing the learning goals of the course, and include critical reflection designed to contextualize the experience in a wider, transferable sense [3].

Rupnow et al. [4] stated that engineering programs have, “increasingly begun to incorporate service-learning into their coursework.” ([4] p. 4) The contextualizing of engineering in light of real world application, engagement, and service, whereby there is a real partner in the work that is being done, has been connected to students’ consideration of the real-life complexities that accompany any engineering challenge. These real-life complexities influence designs, approaches, and dynamics of a task [5]. Additionally, engineering as a field recognizes its commitment to social responsibility as identified explicitly in their Code of Ethics, “... engineering has a direct and vital impact on the quality of life for all people....” [6] Much of the engineering service-learning course research regarding student learning outcomes points towards the imperative of practically understanding and experiencing what it “means to be a good engineer” ([4] p. 4) through the alignment of the technical engineering and non-technical human aspects associated with the field.

While the use of artistic expression as a critical reflection tool is widely researched [7][8], the marriage of arts as an interdisciplinary curricular partner is novel. For example, Taylor and Ladkin recognized two primary forms and processes of knowing - presentational and propositional. Presentational processes are primarily based on an individual reflector’s self-expression and meaning-making by way of aesthetic mediums (consider design or symbols); whereby, propositional processes are typically framed by structured, informative statements (consider words and logic based statements.) In this, Taylor and Ladkin invited learners to articulate their learning through more than one way of demonstrating their knowledge. This also reinforces the demonstration of their knowledge. Again, the connection of arts and engineering within context of service-learning pedagogy is a relatively novel approach to the teaching of both subjects and the use of service-learning pedagogy in an interdisciplinary context.

Additionally, a person would need to look no further than an iPhone or an Android device to see the marriage of aesthetic (design) and functionality (use). The alignment of engineering and artistic design through the interdisciplinary service-learning course design is innovative and should meet the outcomes typically attributed to service-learning courses in both engineering and arts-based design courses and may uncover additional, high-order outcomes through the marriage of these two robust disciplines. This is particularly likely with the support of the arts-based natural alignment with presentational ways of articulating knowing, learning, and understanding.

Partnership Development, Project Design and Execution

This service-learning project is a collaboration among three parties: (1) an upper-level engineering class, (2) a freshman art class, and (3) a community partner with young clients on

the autism spectrum. The partnership was fostered by the desire of the instructors to inspire our students to master programming skills, and our wish to create a fun project for the FSF clients, as we know well that the student mentors learn the most themselves. When the FSF clients visited campus, they had fun learning digital drawing and Arduino programming (see some photos and videos at https://yan.wcu.edu/fsf_sp19/). They grew more confident, and they actively proposed ideas for the service learning project. Meanwhile, the students from both classes enjoyed sharing their expertise as mentors, which reinforced their own learning. The learning objectives of the three parties are achieved through their interactions with a common goal, that is to learn to use the Touch Board and create projects using it.

The Touch Board is essentially an expanded version of an Arduino board (with pins in the regions of E and F in the left photo in Figure 1) and a capacitive sensing chip breakout board with 12 metal pins (in the regions of G and H). Bare Conductive has provided a driver library for the capacitive sensing board, some sample sketches, and an online github with other sketches (<https://github.com/BareConductive>).

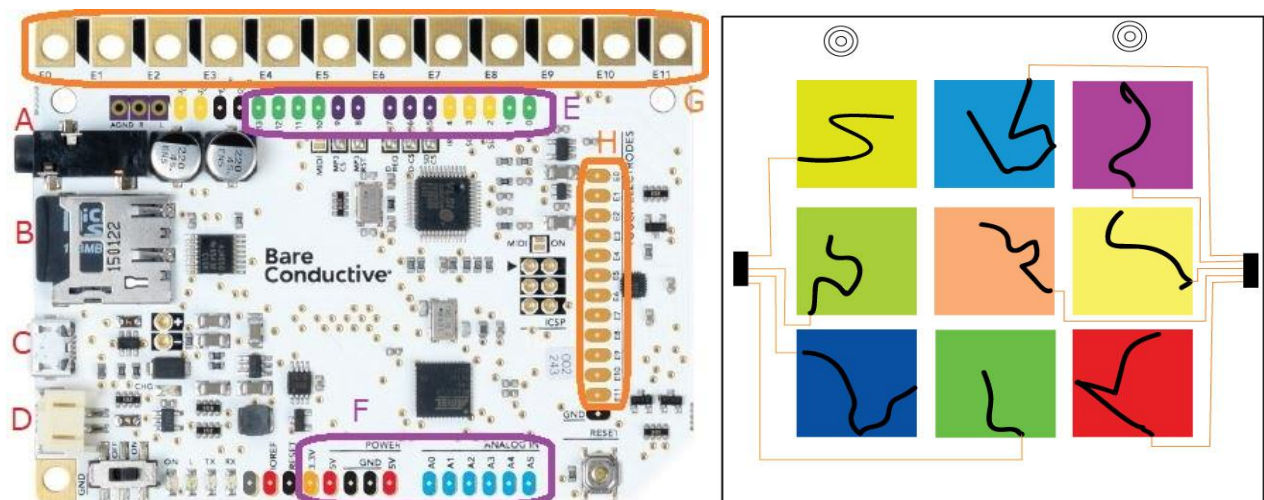

Figure 1. The layout of the Bare Conductive Touch Board (on the left) and the presentation layout of the FSF artistic project (on the right)

In the left side of Figure 1, A is the audio jack plug to a speaker; B is the slot for the memory card that stores the sound tracks; C is the slot to plug in a Micro-USB B cable for programming and power. D is the slot for a one-cell 3.7 V LiPo (Lithium Polymer) battery that uses a 2-way JST PH connector (pin 1 positive, pin 2 negative) and the battery is recommended to have a capacity of at least 400 mAh, but preferably 800 mAh to 1200 mAh. These features enable Touch Board to stand alone by itself and react with pre-recorded sound tracks. The electrodes in the orange box G and the pins in orange box H are equivalent, which are connected to the capacitive sensing chip. One can solder some single-row header pins into the slots inside the boxes E, F, and H, to use removable wires for prototyping easily. The bigger metal pins in box G can be connected to other parts of the circuits using cold-soldering or alligator clippers. The cold-soldering technique uses the electric paint as the connector. When the paint dries it completes the connection to the rest of the conductive-paint based circuit.

The FSF project is displayed on a wooden board (as shown in the right diagram in Figure 1), framed in 3 rows and 3 columns. Each cell will contain a 10 inch by 10 inch piece of paper with the printed compositions digitally-drawn by each FSF client. Each composition will include some areas painted with the black electric paint that when touched will trigger a sound. The electric paint will be connected to the Touch Board using copper conductive tape or wires, as shown in the demo in Figure 2. Two Touch Boards and two speakers will be surface mounted to a 4 foot by 4 foot plywood board. The art and engineering students facilitate the FSF clients to design the painting, choose the sound track, and wire up the board to the paint regions and do the programming. The students from both classes will mentor the FSF clients to achieve the effects they desire.

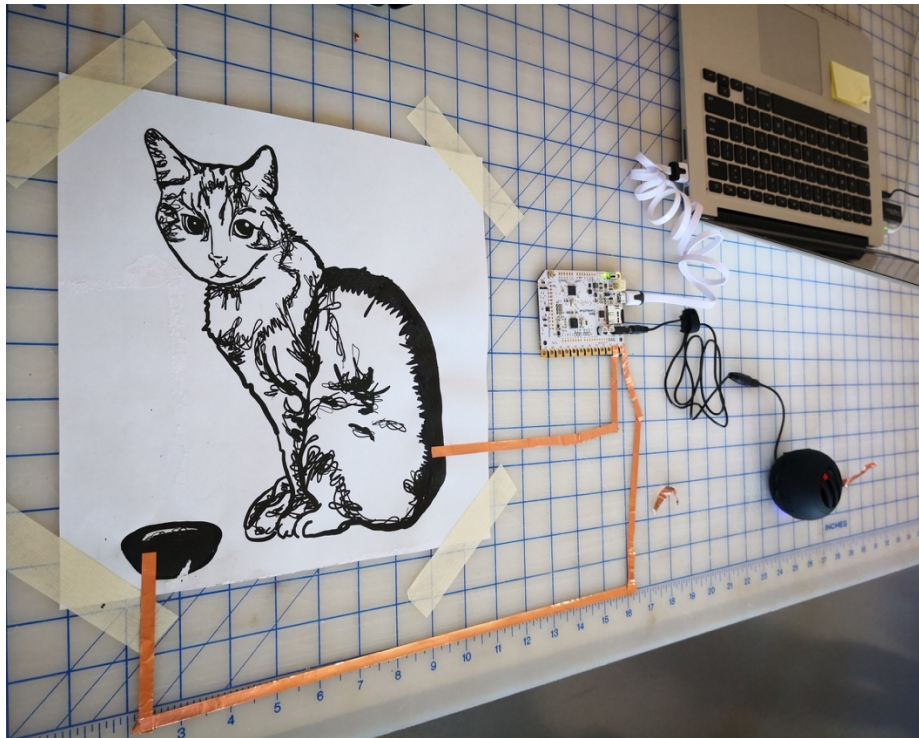

Figure 2 – A Sample Layout As a Demonstration to the Clients

The FSF clients choose the subject of their compositions and where to add the conductive paint trigger, as shown in Figure 3. The conductive paint is connected to a capacitive touch electrode pin on the Touch Board. There are 12 such pins (E0-E11) on each board, and one Touch Boards would be enough to handle the 9 compositions, but two Touch Boards are more convenient to wire the circuit than using one board, and it allows multiple objects to be the touched in a single composition. Therefore, we used two Touch Boards that are surface mounted near the top of a 4 foot by 4 foot plywood board for scalability, as shown in Figure 4. The speakers are mounted along the top of the plywood for safety. The paper compositions are secured on the board using tapes allowing for easy removal and replacement with new works.



Figure 3 – Students Working together with Farm Clients



Figure 4 – Students & Faculty Working on the Farm Project

Meanwhile, the engineering and art students explore ideas to build their own set of projects that incorporate the Touchboard usage. The art students are more focused on artistic designs, while the engineering students are more focused on adding other actuators such as LEDs and motors.

On April 26, 2019 an exhibition will be held to showcase the FSF project, as well as the projects from the art class and the engineering class. These demonstrate what the Touch Boards can do and as inspirations for future projects.

Reflections in Service Learning

An established and widely accepted practical approach to critical reflection within the pedagogy of service-learning was developed by Ash and Clayton [9] and is referred to as the **DEAL** Model. According to Ash, Clayton, and Moses [10] and Ash and Clayton [11], the DEAL Model consists of three sequential steps following a student's engagement in a service experience:

1. **Description** of service experiences in an objective and detailed manner;
2. **Examination** of those service experiences in light of reflection prompts according to a course's learning goals;
3. **Articulation of Learning**, including goals for future action that can then be taken forward into the next experience for improved practice and further refinement of learning.

The Description, Examination, and Articulation of Learning all occur in sequence after a service experience has been completed or repeated after each service interaction.

A short reflection through the DEAL Model will be carried out after each phase, in the form of oral discussions. A detailed reflection using the DEAL Model will be carried out at the completion of the service learning project, in the form of questionnaires. The authors have obtained an approved IRB and the questionnaires will be administered through Qualtrics online. The same set of Qualtrics survey will be administered in both the engineering and art classes. It will be interesting to see if such a collaborative project will have different effects on participants from different disciplines. The majority of the Qualtrics survey questions capture the student experience using the Likert scale for quantitative research, but there are open-ended questions to invite students to share their experiences freely for qualitative research. This service learning project will be studied using the mixed-methods approach.

The engineering students are required to consciously incorporate their experiences gained through the service learning project into their final project for their course, when they apply their knowledge obtained from the project and examine its effectiveness and suitable scope.

The FSF clients will also be surveyed to see what they have learned and how much they have enjoyed participating. The FSF clients do not have formal learning objectives, but their opinions will be helpful in assessing the impact and identifying opportunities for future developments.

Successes, Lessons Learned, and Transferability

The greatest success of this service learning project is that the project idea generated a high level of interest from the team and other stakeholders, such as the art and engineering students, the FSF clients (and their guardians), university colleagues, and funding agencies. The objective of the project elicited many offers to contribute and participate. There was little need to advocate for resources and time. The team sees great potential in interdisciplinary collaboration and project-based service learning. The work also shows the value of tools like the Touch Board. Meanwhile, the multi-disciplinary format of the course provides benefits normally unavailable to our students. In addition to the DEAL reflection survey, we will administer another survey to gather student thoughts on the Touch Board as a vehicle for future projects.

Another important success is the effectiveness of student learning in this process. The engineering students learned Arduino programming well enough in lectures/labs, but it was when they talked with the FSF clients one-on-one to guide them through the LED blinking exercise that they really took on the ownership to facilitate others' learning processes and deepen their own learning. They encouraged the clients to try out variations of the coding and they could respond to the clients' custom requests to integrate what they have learned in class earlier. The team has learned quite a bit about what the FSF clients, and the general population on the autism spectrum, would need. One example is a preference for written instructions over oral instructions. A second example, the clients perform better in a quiet environment that allows them to focus on the exercise at hand. And a third example, the clients appreciate everyone wearing name tags before they know them well. The team believes that the Touch Board project, the interdisciplinary collaboration in a service learning project, and the general understanding of how to work with others, can be transferred elsewhere.

Conclusions and Next Steps

The engineering course in this collaboration is the first one to be designated as a service-learning course (SLC) within the College. It is novel to carry out a service-learning project between Engineering and ART classes. The service-learning project described in this paper is ongoing in spring 2019 after careful preparations and planning. The authors met with the community partners in summer 2018, solicited more than \$4500 support for project materials through both internal and external grants in fall 2018, and hosted clients on campus multiple times in Spring 2019. The final project for the community partner will be left at the FSF to serve their clients on the autistic spectrum, and the clients would have learned how to update the artwork or make revisions to this project. Other project materials will be reused in the art and engineering classes. On April 26, 2019, an exhibit will be organized to showcase the Farm project, as well as the projects made by the art students and by the engineering students, to demonstrate the potential of using Touch Boards. This paper describes the work in progress, all parties are very much looking forward to continuing this project. The instructors expect the students to achieve their learning outcomes in an educational interdisciplinary setting and we will work together to ensure that this experience is enriching for the FSF clients.

Acknowledgements

This project is supported by the American Society of Engineering Education (ASEE)'s Electrical and Computer Engineering Technology Department Heads Association (ECETDHA) Minigrant, WCU Intentional Learning Grant, WCU Faculty Institute of Community Engagement Grant, and the WCU Academic Project Grant. Any opinions, findings, and conclusions or recommendations expressed in these materials are those of the authors and do not necessarily reflect the views of the funding agencies.

References

- [1] Cielo, C., Durlak, J., & Dymnicki A. (2011). A meta-analysis of the impact of service-learning and students. *Journal of Experiential Education* 34(2), p. 164-181.
- [2] Bringle, R., & Hatcher, J. (1995). A service learning curriculum for faculty. *Michigan Journal of Community Service Learning*, 2, p. 112-122.
- [3] Felten, P., & Clayton, P. H. (2011). Service-learning. *New Directions for Teaching and Learning*, 128(Winter), p. 75-84. doi:10.1002/tl.470
- [4] Rupnow et al. (2018). Rupnow, R., Davis, K., Johnson, R., Kirchner, E., Sharma, J., Talukdar, S.R. (2018). Service experiences of undergraduate engineers. *International Journal of Research on Service-Learning and Community Engagement*, 6(1), Article 14.
- [5] Bielefeldt et al. (2010). Bielefeldt, A. R., Paterson, K. G., & Swan, C. W. (2010). Measuring the value added from service learning in project-based engineering education. *International Journal of Engineering Education*, 26 (3), p. 535-546. 1206-1220.
- [6] National Society of Professional Engineers (NSPE) Code of Ethics
<https://www.nspe.org/resources/ethics/code-ethics>
- [7] Lane Perry, Lee Stoner, Max Schleser, Krystina R. Stoner, Daniel Wadsworth, Rachel Page and Michael A. Tarrant (2015). Digital media as a reflective tool: creating appropriate spaces for students to become introspective. *Compare* 45(2), p. 323–330.
- [8] Taylor, S., & Ladkin, D. (2009). Understanding Arts-based Methods in Managerial Development. *Academy of Management Learning & Education* 8(1): p. 55–69.
- [9] Ash, S. & Clayton, P. (2004). The articulated learning: An approach to reflection and assessment. *Innovative Higher Education*, 29, p. 137-154.
- [10] Ash, S. Clayton, P. & Moses, J. (2007). Teaching and learning through critical reflection: An instructors' guide. *Sterling, VA: Stylus Publishing*.
- [11] Ash, S., & Clayton, P. (2009). Generating, deepening, and documenting learning: The power of critical reflection in applied learning. *Journal of Applied Learning in Higher Education*, 1, p. 25-48.