

## **Enhancing Undergraduate Understanding of Subtractive Manufacturability through Virtualized Simulation of CNC Machining**

**Mr. Roby Lynn**

**Dr. Kathryn W. Jablokow, Pennsylvania State University, Great Valley**

Dr. Kathryn Jablokow is an Associate Professor of Engineering Design and Mechanical Engineering at Penn State University. A graduate of Ohio State University (Ph.D., Electrical Engineering), Dr. Jablokow's teaching and research interests include problem solving, invention, and creativity in science and engineering, as well as robotics and manufacturing education. In addition to her membership in ASEE, she is a Senior Member of IEEE, a Fellow of ASME, and the recipient of the 2016 ASME Ruth and Joel Spira Outstanding Design Educator Award. Dr. Jablokow is the architect of a unique 4-course module focused on creativity and problem solving leadership and is currently developing a new methodology for cognition-based design. She is one of three instructors for Penn State's Massive Open Online Course (MOOC) on Creativity, Innovation, and Change, and she is the founding director of the Problem Solving Research Group, whose 50+ collaborating members include faculty and students from several universities, as well as industrial representatives, military leaders, and corporate consultants.

**Prof. Christopher Saldana**

**Dr. Thomas Marshall Tucker, Tucker Innovations**

Dr. Tommy Tucker is the CEO and owner of Tucker Innovations. He has a Ph.D. in Mechanical Engineering from the Georgia Institute of Technology. He has over 15 years of experience writing computationally intensive software applications for engineering, medical, and defense applications. After spending the early part of his career at high tech start-up companies, Dr. Tucker founded Tucker Innovations to facilitate his software consulting activities. Through Tucker Innovations, Dr. Tucker has aided various organizations in producing software applications from concept to product launch and continuing through multiple release cycles. Clients range from small high tech startup companies to large organizations such as 3M, 3D Systems, the US Navy, and US Air Force.

**Prof. Thomas Kurfess, Georgia Institute of Technology**

Thomas R. Kurfess received his S.B., S.M. and Ph.D. degrees in mechanical engineering from M.I.T. in 1986, 1987 and 1989, respectively. He also received an S.M. degree from M.I.T. in electrical engineering and computer science in 1988. He currently is a Professor in the Woodruff School of Mechanical Engineering at Georgia Tech where he holds the HUSCO/Ramirez Distinguished Chair in Fluid Power and Motion Control.

# Enhancing Undergraduate Understanding of Subtractive Manufacturability through Virtualized Simulation of CNC Machining

## Abstract

The design process can often introduce manufacturing challenges, and designers must be able to understand these challenges in order to minimize them. Frequently, the experience level of mechanical engineering students is insufficient for them to consider the limitations that manufacturing processes impose upon design, and they often design parts that are either difficult or impossible to manufacture. This work describes the development, implementation, and analysis of a system used to rapidly provide students with the knowledge they need to consider manufacturing challenges for machining processes. An experimental group of students was trained in the use of a software package (SculptPrint) that provides visualizations of the turning process and taught how to operate various computer numerical control (CNC) machine tools. A separate control group of students was trained on the operation of manual machine tools and did not receive access to the turning visualizations. Knowledge assessments were given to both groups to measure their understanding of a variety of topics in manufacturability. Analysis of the survey results indicates that student understanding of geometrical limitations in the turning process can be dramatically improved by employing visualizations of manufacturing processes.

## Keywords

Design for manufacturability, simulation-based learning, computer-aided manufacturing, virtualization, voxel, CNC machining

## Introduction

Engineers must consider a variety of factors while designing a component or developing a manufacturing process for a part; often, the consideration of such factors is out of reach for students with little to no experience in manufacturing. Both design and manufacturing are addressed in many undergraduate engineering curricula, but frequently, students struggle to synthesize the necessary knowledge to practice design-for-manufacturability (DFM) effectively. DFM is the practice of design in such a way that manufacturing considerations are taken into account during the design process. In order for students to be able to design parts that are readily manufacturable, their competence in DFM must be improved. For subtractive manufacturing (SM) processes, also known as “machining,” these considerations include cutting tool size, feature accessibility, workpiece material, and fixture configuration. Both designers and manufacturing engineers need significant experience to be able to think effectively about these considerations; this experience is typically gained through actual engineering practice and real-world skill building, not lectures and textbooks.

Students view additive manufacturing (AM) processes, also known as “3D printing,” as the obvious choice for any part because of its perceived ease of its implementation. This can be problematic in some cases, such as those where durability, high strength, and/or good surface finish are required. AM processes are ideally suited for producing parts with highly complex geometries that cannot be made with other, more traditional, processes. Even when a subtractive manufacturing (SM) process, such as machining, could produce a certain part with superior strength and surface finish to an additively manufactured version, students frequently still choose AM. Although AM processes are ideal in some situations, and are sometimes the *only* possible

choice, SM processes are equally (or even more) valid in other scenarios. It has been found that a large percentage of undergraduate students prefer AM processes because they are unfamiliar with SM. For students to be effective designers and engineers as they move into the workforce, they must not only be comfortable with both AM and SM processes, but they must also have the ability to fluidly move between the realms of thought needed for AM and SM [1].

This paper presents methodologies to increase student understanding of SM processes using computer-based simulations; a voxel-based computer-aided manufacturing (CAM) software known as SculptPrint [20] was used to provide these simulations. SculptPrint enables interactive, video game-like visualizations of a manufacturing process for various part and tooling geometries. A case study was performed in a required, high-enrollment, sophomore-level mechanical engineering course to evaluate the improvement in student understanding of the turning process. Experimental groups of students from the course were selected to receive both experience with the CAM software and training on computer numerical control (CNC) machine tools. Simultaneously, the remainder of the students in the course served as the control group; these students received training on manual machine tools, but they were not provided with visualizations of the turning process. Process planning for SM operations was introduced to the experimental group using the software, and these students designed and created multi-part assemblies using the CNC machine tools they were trained to operate. Online assessment instruments were developed and deployed using the Qualtrics platform; these assessments were given throughout the training procedure to compare the level of understanding of SM processes between the students who did and did not receive exposure to the CAM software.

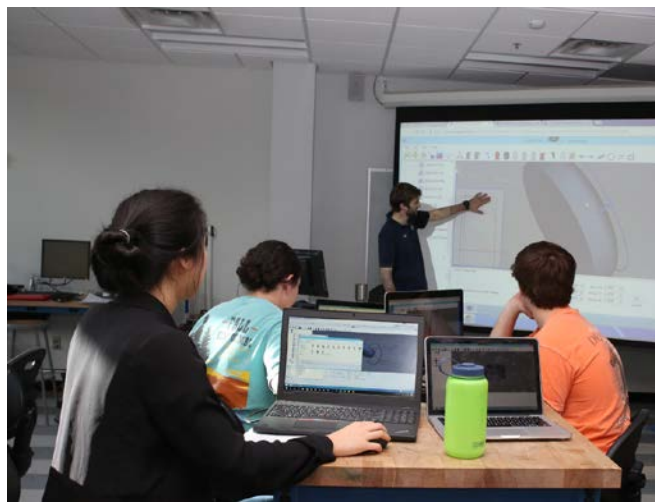
## **Background**

The understanding of manufacturing processes is essential in the practice of engineering, but it is not heavily emphasized in the majority of engineering curricula [2]. Universities most frequently provide one required course in manufacturing processes and may provide others as electives [3]. Regardless of the quality of manufacturing education students receive, students are still expected to be capable of fabricating the components and devices they create without necessarily having formal training in the implementation of a manufacturing process. The difficulties in implementation training can be attributed, in part, to the fact that extensive capital expenditure is required to develop a functional manufacturing facility [4]. Additionally, undergraduate-level treatment of automated machining processes, known as computer numerical control (CNC) machining, is provided even less frequently than that of manual machining [5]. CNC machining is of utmost importance in industry, and students must understand the fundamentals and limitations of CNC machining in order to be effective designers.

This work seeks to develop a simulation-based learning (SBL) approach to manufacturability education that relies on the use of computer visualizations. SBL is a technique that uses artificial experiences to replace real-world experiences for training purposes. SBL is frequently applied in the fields of medicine, aviation, and military training to recreate accurate experiences [6]. SBL can be implemented using actors, props, or games and is often used in professional education settings, where the efficiency of teaching real-world skills is of paramount importance [7]. SBL not only enables the development of intuition that would be difficult to teach in a traditional classroom setting, but it also does not require the physical operation of expensive and often hazardous manufacturing equipment and is thus an ideal strategy for manufacturing education [8].

SBL has been used in engineering education for a number of different objectives. Researchers have employed computer-aided design (CAD) and computer-aided engineering (CAE) software packages to evaluate the effectiveness of simulations in teaching engineering concepts. Ebner and Holzinger implemented a computer game to simulate concrete structure design in an effort to better educate civil engineering students [9]. Although the goal of the implementation was simply to provide an alternative to traditional approaches to teaching, the researchers found that students who used the game scored much higher on user empowerment and fun factor indices than students who did not use the game. Gillet, Ngoc and Rezik deployed simulated experiments in fluid mechanics, biomechanics, and automatic control using a web-based flexible learning system [10]. A collaborative workspace was also provided to the students that allowed them to solve problems together; this study showed that engineering students are generally receptive to computer-assisted learning practices. Another family of software packages, known as computer-aided manufacturing (CAM) software, is used by engineers to plan manufacturing operations for CNC machine tools. Some researchers have begun to apply CAM software in the classroom to help educate students about concepts in manufacturing [11]. CAM has been shown to accelerate the pace of teaching students about subtractive manufacturing concepts [12], [13]. Koh, *et al.* developed interactive simulations on the operation of milling, turning, and drilling machines; results from a post-training exercise performed by the researchers demonstrated that students exposed to the computer simulations of those machine tools had a superior grasp of their operation compared to students who simply received lectures [14].

The current research relies on the use of a new CAM system known as SculptPrint [20] to provide students with rich visualizations of the turning process [15]. SculptPrint utilizes a voxelized part representation, as opposed to typical parametric part representations, to enable the accurate simulation of tool marks, scallops, and gouges [16]. *Voxels* are the three-dimensional equivalent of image pixels, and they can easily be added or subtracted from a part model to simulate material deposition or removal, respectively [17]. SculptPrint was provided to study participants through virtual desktops, which allow students to perform visualizations using their laptops either at home or in class [18], [19]. The students selected to participate in the current study, a subset of which are shown in Figure 1, were enrolled in an introductory design/build course for sophomore mechanical engineering students at the Georgia Institute of Technology.



*Figure 1. Study Participants Engaged in Training Procedure. Photo Credit: C. Hobbs*

## Experiment Design

Two groups were selected to participate in this study: a relatively small treatment group and a larger control group. Due to constraints in resources available for the implementation of this study, the size of the treatment group was limited to two sections of the course with approximately 20 students each; the remainder of the students enrolled in the course (approximately 200 students) served as the control group. Some data loss was experienced in this study due to two major factors: first, not all of the students gave permission for their data to be published; and second, all records for students that did not complete all of the required Qualtrics assessments were removed. Although the response rate for each individual survey was high, if a student did not complete one of the surveys, a study-wide comparison of that student's performance to the remainder of the group could not be performed. After these unusable student records were removed, 15 students remained in the treatment group, and 132 students remained in the control group. The populations of the training and control groups as percentages of the total population of 147 participants are given in Table 1.

*Table 1. Groups Used for Study*

<b>Group</b>	<b>Size (Students)</b>	<b>Percentage of Study Population</b>
<i>Control</i>	132	89.8%
<i>Treatment</i>	15	10.2%
<i>Total Population</i>	147	100%

The treatment group received both training in and hands-on experience with the voxelized CAM package, SculptPrint. A series of online assessment instruments was completed by the students throughout the training procedure. The assessment instruments contained a broad range of questions, from simple questions about the fundamentals of machining to more complex questions regarding tooling geometry. The assessment questions were broken into three separate assessments: the Pre-assessment, the Pre-Test, and the Post-Test. The Pre-assessment contained questions to gather data on students' prior experience in manufacturing processes, such as milling, turning, and 3D printing. The Pre-Test assessed students' knowledge of the fundamental concepts of machining, such as axisymmetry and the difference between additive and subtractive manufacturing processes. Both the Pre-assessment and the Pre-Test were given before any machining training was provided to the students. The Post-Test, which was given after machining training, contained more advanced machining questions, such as sketching of a part after a turning operation with a particular cutting tool. The treatment group was given an additional assignment, the SculptPrint Exercises, which was completed by the students as homework during the training procedure. This assignment asked students to perform a variety of visualizations of the turning process using SculptPrint. The timeline of assessment deployment with respect to machining training is presented in Table 2.

Table 2. Assessment Schedule

Week	Lecture	Training Exercise	Assessment	Assessment Scope
1	Design	None	Pre-assessment	Prior Experience
2	Machining	None	Pre-Test	Basic machining questions, manufacturing process choice
3-5	Safety, Quality Assurance	Machining Training	SculptPrint Exercises <sup>1</sup>	Visualizations of turning process
6	DFM	None	Post-Test	Detailed machining questions, manufacturing process choice

<sup>1</sup>Only given to treatment group

### Initial Data Collection

Before any training began, students were asked to complete both the Pre-assessment and the Pre-Test to gather data on their initial understanding of subtractive manufacturing and design-for-manufacturability. The Pre-assessment asked students to indicate if they did or did not have prior experience in 3D printing, turning, milling, CNC machining, and laser cutting. Additionally, they were asked which of those processes they were most comfortable with, if any. They then completed the Pre-Test, which contained a range of questions regarding the fundamentals of subtractive manufacturing. The types of questions that appeared in the Pre-Test are shown in Table 3. These two assessments were used to quantify differences in students' understanding of SM and DFM between the treatment and control groups before training began.

Table 3. Pre-Test Question Types and Examples

Type	Assessment Question Example
<i>Process Fundamentals</i>	Is turning an additive or subtractive operation?
<i>Machine Capability</i>	In a lathe, does the tool spin or does the part spin?
<i>Fixturing</i>	Should a vise be used on a lathe or a mill?

### Training Procedure

Both groups received training in machining following the initial data collection. The control group received typical hands-on training on both manual lathes and manual milling machines. The students in the control group were then asked to create simple parts that used both the mill and lathe. This training procedure spanned three weeks: the first week consisted of safety and operation training on a lathe; the second week consisted of safety and operation training of a milling machine; and the third week was provided for students to machine one part on the lathe and one on the mill. The training was performed by a teaching assistant, and the students' machined parts were checked for dimensional accuracy after completion. Follow-up training was provided on request from the students if they needed additional help in operating the machine tools. The treatment group received training in the CAM software and on a 2-axis CNC turning center, but this group did not receive training on the manual machining equipment. The treatment group students were taught to operate the CAM software with the help of an instructor during the

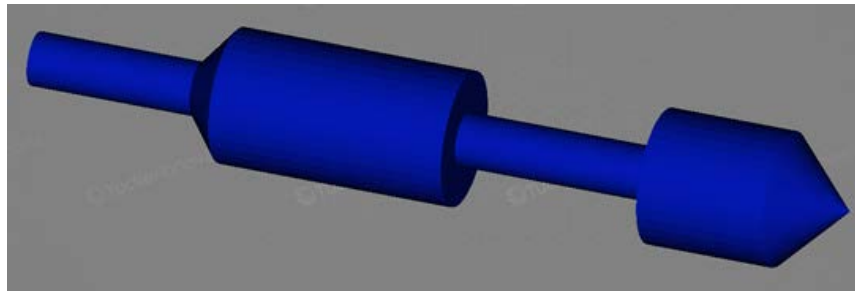
usual course meeting time. They were walked through the process of setting up a part, creating a turning pass, and visualizing the resulting part volume after the virtual machining operation. They were then asked to create toolpaths for a simple yoyo, a finished example of which is shown in Figure 2. Once yoyo toolpath creation was complete, the students were taught to run the CNC turning center to manufacture the yoyo.



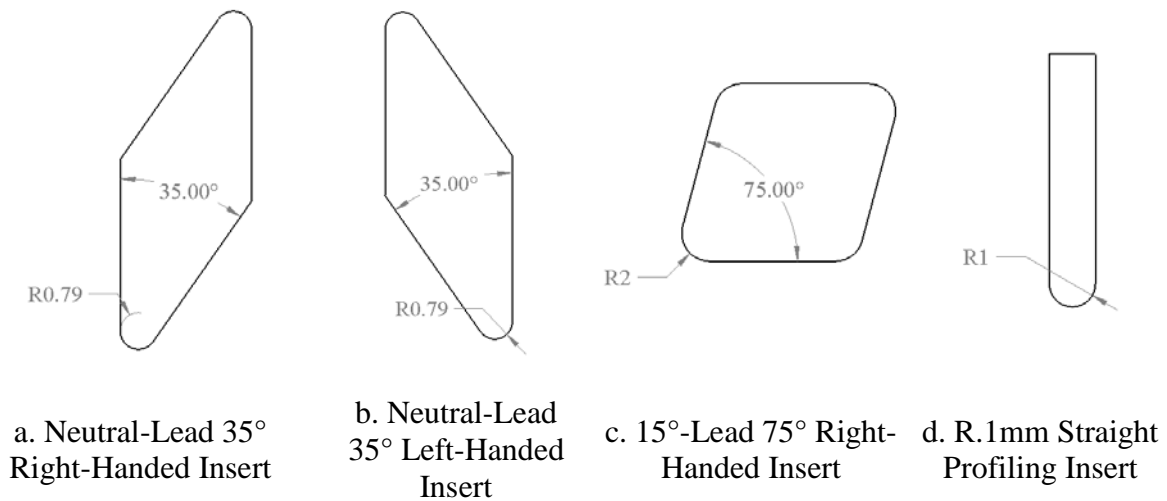
*Figure 2. Student-Created Yoyo*

#### *Visualization Exercise*

Upon completion of both SculptPrint and CNC training, the treatment group received an additional exercise that was not given to the control group; specifically, the SculptPrint Exercises guided students in the treatment group through visualizations of turning a simple part with various types of cutting tools. This exercise was designed to educate students about the maximum relief angles and minimum internal corner radii that can be achieved given the geometry of a cutting insert. The students were asked to use a series of four different cutting tools to attempt to achieve the target part shown in Figure 3. This part contained both positive and negative vertical reliefs that necessitated the use of both right-handed and left-handed tooling. Additionally, no internal corner radii were present on the target part, which was impossible to realize with the given tooling. The profiles of the cutting tools that were provided to the students for this exercise are shown in Figure 4.

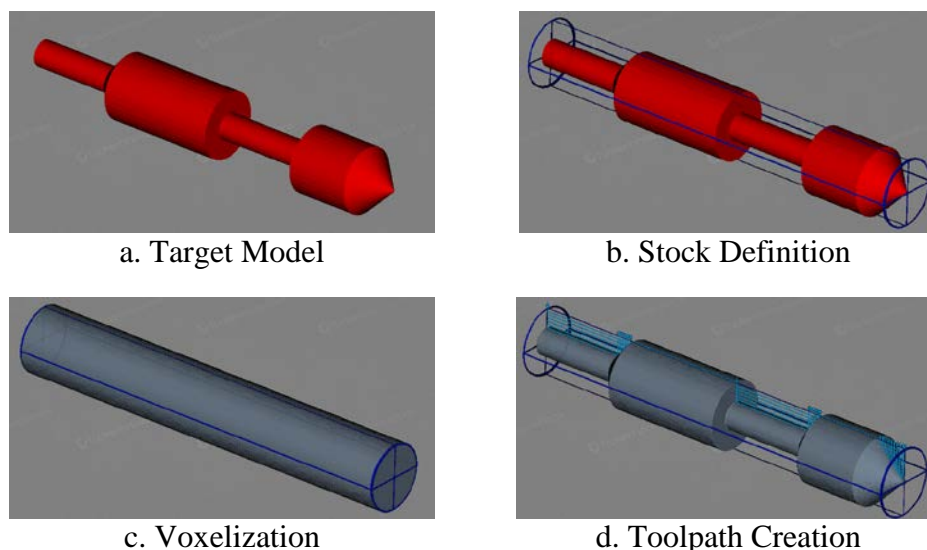


*Figure 3. Target Part for Visualization Exercise*



*Figure 4. Turning Tool Profiles for Visualization Exercise*

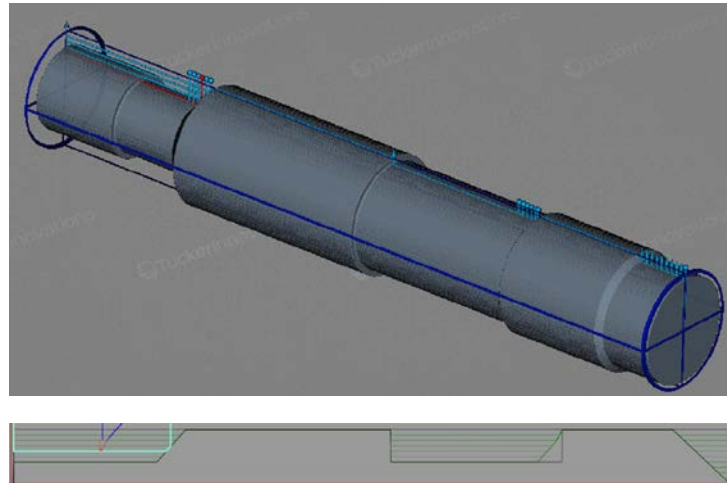
The procedure for simulating the turning operation in SculptPrint is as follows: first, the user imports a model of the target part into the software, which in this case, was the example part from Figure 3. Second, the user defines the coordinate system to be used for the machining operation; for this turning exercise, the Z-axis is defined as the axial direction along the part, and the X and Y-axes are two orthogonal radial directions. Third, the user selects the geometry of the stock that will be used to manufacture the part. Fourth, the user converts the part and stock geometry into a voxel model. Finally, the user selects a cutting tool with which to simulate a turning operation, and SculptPrint generates an interactive toolpath. The user can then accept that toolpath or use a different tool to simulate another toolpath. The students were asked to simulate the turning operation for each of the tools in Figure 4 and then provide their own description of how the resulting part model after machining differed from the target model. An example of the sequence of steps used by the students to perform the machining simulations is shown in Figure 5.



*Figure 5. Visualization Procedure*



Once the toolpath was created, the students were allowed to step through the toolpath to visualize the process. They were provided with a slider that they could use to view the removal of material at different steps within the process. An example simulation of a toolpath using the provided 35-degree right-handed tool is shown in Figure 6. The bottom image shows the toolpath in green lines with the current position of the cutting insert shown in red; the top image demonstrates the resulting volume of the part when the tool is located at the selected position.

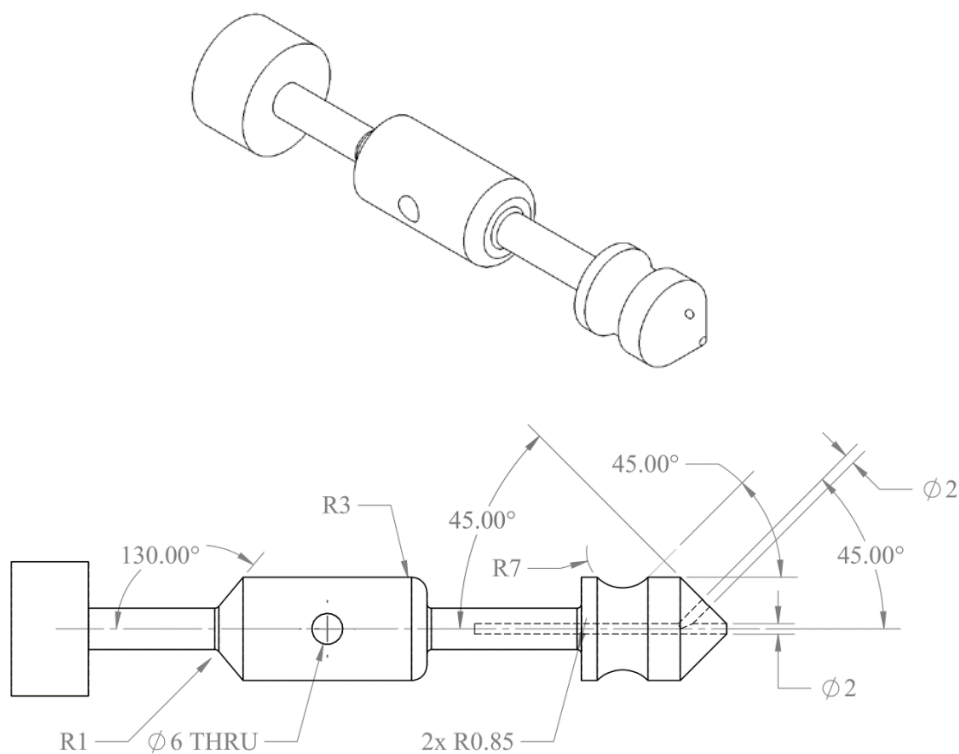


*Figure 6. Toolpath Simulation*

### **Learning Assessment**

Once the respective training protocols had been completed for both the treatment and control groups, an assessment was given to both groups that asked the students to sketch the result of turning a part with a given catalog of tools. This assessment was designed to measure a student's ability to analyze mentally the geometry of a part when turned using various cutting tool profiles. The tool catalog provided was the same as that given in the SculptPrint Exercises, but the target part was different. The geometry of the new part given to the students is shown in Figure 7. The part was similar to the part used for the visualization exercises, but with several key differences: first, the part contained an additional positive relief on the rear; second, it contained a 7mm radius on the outer diameter that was not present on the previous part; third, it contained a 3mm fillet; and finally, the part contained axial, transverse, and off-axis drilled holes.

Students were asked to sketch the result of both rough turning the part with the 75° right-handed tool and finish turning with the 35° right-handed tool. The students were also asked to pick a set of tools that would be capable of manufacturing all of the turned features on the part. As the given part requires turning with both right-handed and left-handed tools to machine all of the features, the students were only given credit if their responses included those tools. The student sketches and responses to the tooling selection question were graded by a manufacturing expert to determine their correctness; students were only given credit for the questions if their answers were completely correct. Figure 8 presents a sample of student responses to the sketching questions. Note that a number of answers were counted as correct for the first sketching question regarding the 75° tool; as long as the students demonstrated a final part volume that could result after a reasonable rough turning operation, they were given credit. Sketch responses for the finish turning operation (the second sketching question) were similar to those of the rough turning operation, but addressed the finished geometry instead of the roughed geometry. As the relief angles left by a particular turning tool are perhaps one of the most significant results of a turning operation, this assessment was designed to measure whether or not students understood how the provided tools would create reliefs.



*Figure 7. Example Part for Sketching Assessment*

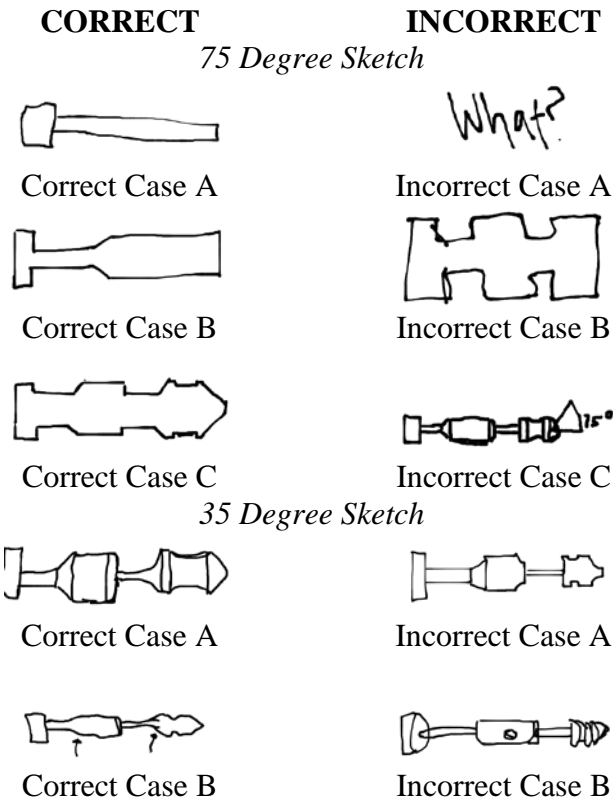


Figure 8. Types of Correct and Incorrect Responses to Sketching Questions

## Results

### *Prior Experience*

Given the rise in popularity of makerspaces and the 3D printers that are inextricably linked to them, the majority of study participants were expected to not only have experience operating a 3D printer, but also to be most comfortable with 3D printing in comparison to other manufacturing processes. Figure 9 shows the reported prior experience of both the control and treatment groups before any training began. While there are distinct differences between the groups (most notably, that the treatment group possessed significantly fewer students with experience in manual machining before the training), the most visible result is the large percentage of students in both groups that reported 3D printing experience. When asked which manufacturing process they were most comfortable with, students responded in a similar way. The responses to this question are shown in Figure 10. Not surprisingly, the highest percentages of students in both groups reported that they were either most comfortable with 3D printing or not comfortable with any manufacturing processes. The fact that the majority of students from this population were either uncomfortable with or completely unfamiliar with SM processes presents a challenge for their future careers: they must be comfortable with both AM and SM processes in order to succeed in the workforce. The manufacturability training for SM presented in this work is being designed to overcome this gap in student knowledge.

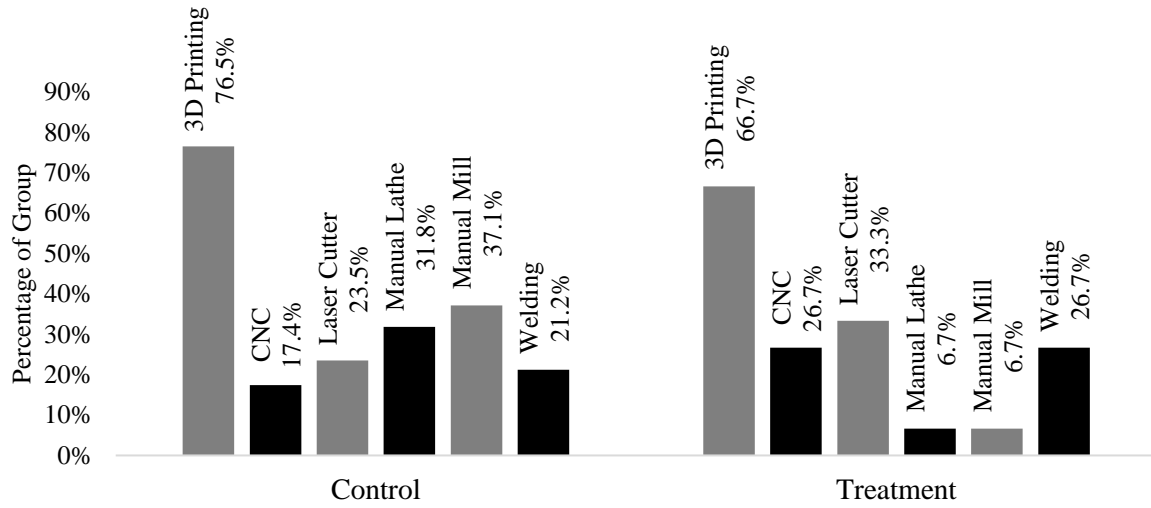


Figure 9. Prior Experience by Group

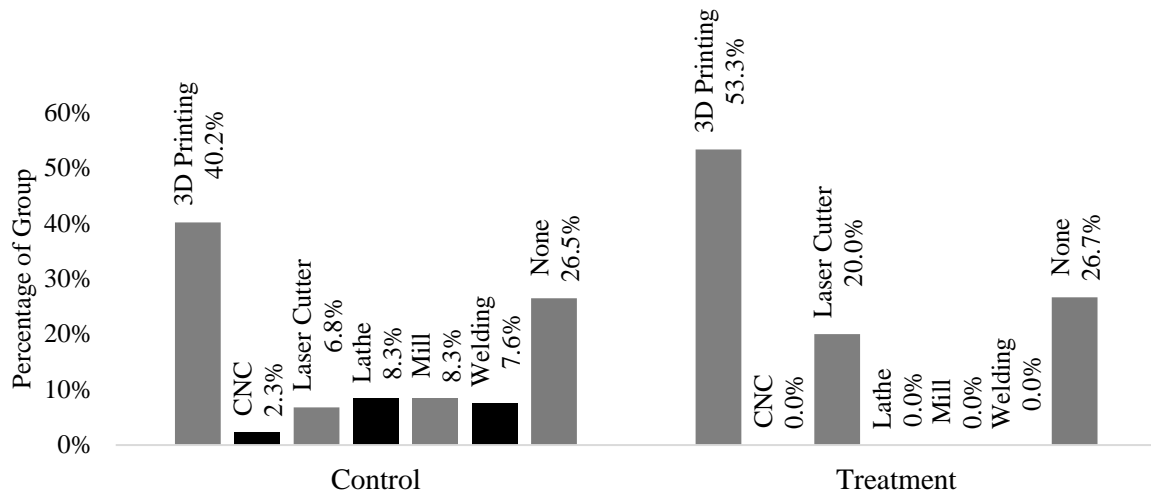


Figure 10. Students' Indication of the Process with which They Are Most Comfortable

### Understanding of SM before Training

In order to understand differences between the control and treatment groups that may be caused by students' prior experience before training, the students were examined using the Pre-Test before any training began. This instrument asked students a range of questions related to the fundamentals of machining processes. The score statistics for this instrument, graded out of a total of 8 points, are shown in Table 4. The difference in means ( $\Delta\mu$ ) is defined by Equation 1,

$$\Delta\mu = \mu_{\text{Treatment}} - \mu_{\text{Control}} \quad (1)$$

where  $\mu_{\text{Treatment}}$  and  $\mu_{\text{Control}}$  are the mean scores of the control and treatment groups, respectively. The results of a two-sample *t*-test performed on the score statistics indicate that the difference in means between the control and treatment groups on the Pre-Test is not significant at the  $\alpha = 0.05$  level. This suggests that any differences in prior experience between the groups did not significantly influence their performance on this assessment. In other words, the groups were essentially the same in terms of understanding of SM before training.

Table 4. Score Statistics for Pre-Test

	$\mu$	$\sigma$	$\Delta\mu$	95% CI for $\Delta\mu$	$t$ -Statistic	$p$ -Value	df
Control	4.24	1.51					
Treatment	4.33	1.35	+0.091	(-0.689, 0.871)	0.24	0.809	18

### Understanding of Tooling Geometry after Training

The percentage of students responding correctly to the sketching questions, by group, is shown in Figure 11. It is apparent that the treatment group performed substantially better than the control group did on the tooling geometry assessment. The discrepancy between scores on the 75° and 35° tool sketches can be attributed to the grading procedure: students were given credit for the 75° sketch for a range of answers, as they were only asked to sketch the result of a rough turning operation, which could be done in a multitude of ways. However, for the 35° tool sketch, they were asked for the result of a finished turning operation, implying that the final turned geometry should have been provided.

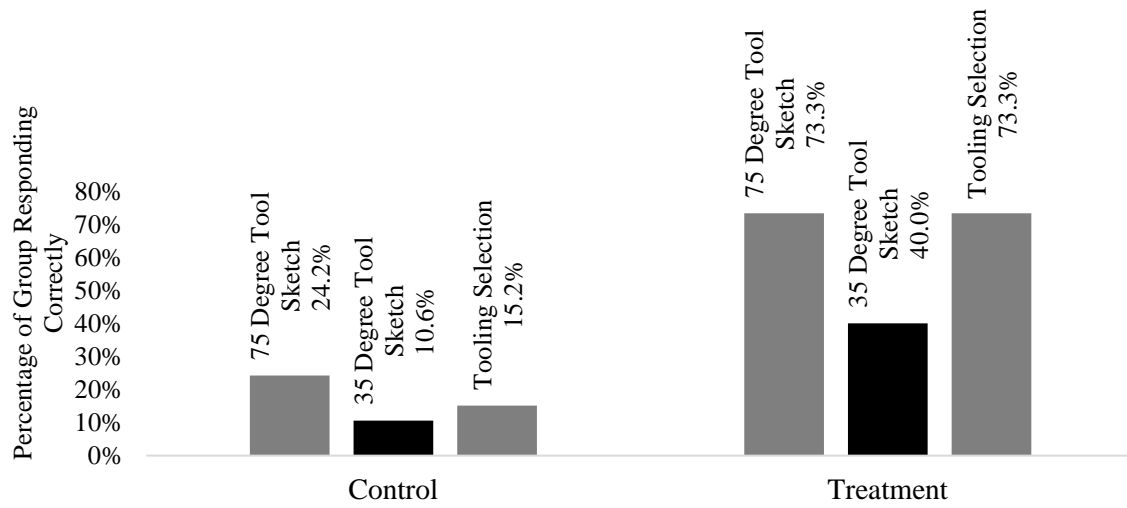


Figure 11. Group Performance on Tooling Geometry Questions

The remainder of the Post-Test consisted of questions on topics such as right-handed versus left-handed tooling, the included angle of a cutting tool, and the choice of machine type for an asymmetric part. The Post-Test was graded out of a total of 9 points by a manufacturing expert. The score distribution on the Post-Test is shown in Figure 12. From both visual inspection and a statistical analysis of the Post-Test results (see Table 5), it is apparent that the treatment group performed far better than the control group did on the Post-Test. The results from a two-sample  $t$ -test demonstrate that the score increase of the treatment group, as compared to the control group, is significant at the  $\alpha = 0.05$  level. Interestingly, the subset of students that reported not being comfortable with any manufacturing processes actually showed the largest improvement in the treatment group. However, this increase is not quite significant at the 0.05 level ( $p = 0.053$ ).

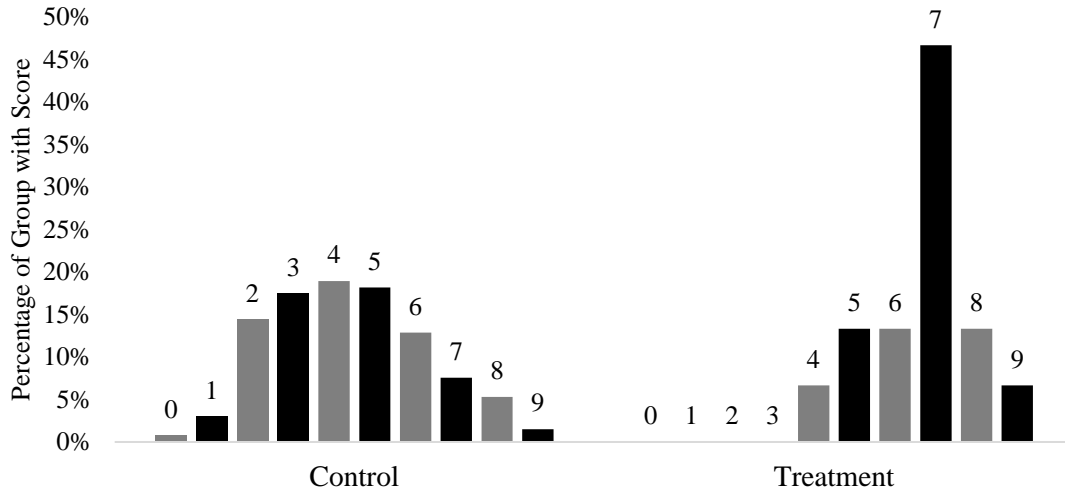


Figure 12. Score Distribution on Post-Test

Table 5. Score Statistics for Post-Test

Entire Population								
	Score Range	Mean Score	$\sigma$	$\Delta\mu$	95% CI for $\Delta\mu$	t-Statistic	p-Value	df
Control	(0, 9)	4.37	1.90	+2.30	(+1.52, +3.07)	6.16	1.19E-5	21
Treatment	(4, 9)	6.67	1.25					
Students Not Comfortable with Any Manufacturing Processes								
Control	(0, 6)	3.43	1.60	+3.32	(-0.07, +6.72)	3.11	0.053	3
Treatment	(4, 9)	6.75	1.78					

The analysis of the Post-Test results indicates that the treatment group’s exposure to visualizations of the turning process was effective in teaching students about geometric considerations in machining. These considerations are necessary in DFM practice for mechanical engineers, and the results suggest that visualizations are a more effective training tool than simple training on manual machining equipment.

### Conclusions and Future Work

This paper presented the design and implementation of a study to measure the effectiveness of deploying visualizations of the turning process in educating students about DFM considerations. A novel voxelized computer-aided manufacturing application, SculptPrint, was deployed on virtual desktops to allow students to use the software from their personal laptops and tablets. Assessment instruments were developed and deployed to measure the students’ understanding in a variety of topics in subtractive manufacturing and manufacturability. Results from a score analysis of the assessment instruments indicate that providing students with access to the software for visualizations and toolpath planning is more effective in teaching them about geometric considerations in the turning process than simply providing them with training on manual machine tools. This study will be extended with more detailed assessment instruments in

future, larger implementations. Additionally, both multi-axis milling and additive manufacturing will be explored using SculptPrint as a teaching tool.

This work demonstrates a range of implications for engineering educators, specifically for those who teach manufacturing and DFM. The results of this study show that exposing students to visualizations of a manufacturing process is beneficial to increasing their understanding of the process. Instead of the typical approach of providing students with lectures on machining and training on manual machining equipment, students should be provided with interactive visualizations of the machining process. The use of visualizations will enable more efficient training in DFM in both design and manufacturing courses. In the future, training on physical machine tools may no longer be necessary, with students and practicing designers employing computer applications to garner feedback on the manufacturability of their designs instead.

### **Acknowledgments**

This work was supported by NSF CMMI Grants 1547093, 1547021, 1546985, and CPS grant 1329742.

### **References**

- [1] R. Lynn, "Enhancing Awareness of Additive and Subtractive Manufacturability with Voxel-Based Simulations," Georgia Institute of Technology, 2017.
- [2] R. H. Todd, W. E. Red, S. P. Magleby, and S. Coe, "Manufacturing: a strategic opportunity for engineering education," *Journal of Engineering Education*, vol. 90, no. July, pp. 397–405, 2001.
- [3] "Criteria for Accrediting Engineering Programs." ABET Engineering Accreditation Commission, 2014.
- [4] Min Jou, "Development of an e-learning system for teaching machining technology," in *Proceedings of the 2005 International Conference on Active Media Technology, 2005. (AMT 2005).*, pp. 347–352.
- [5] J.-D. Kim and M.-H. Kim, "A study on the design of CNC lathe for education and application," *International Journal of Production Economics*, vol. 25, no. 1, pp. 169–180, 1991.
- [6] F. Lateef, "Simulation-based learning: Just like the real thing.," *Journal of emergencies, trauma and shock*, vol. 3, no. 4, pp. 348–352, 2010.
- [7] R. M. Fanning and D. M. Gaba, "The role of debriefing in simulation-based learning.," *Simulation in healthcare journal of the Society for Simulation in Healthcare*, vol. 2, no. 2, pp. 115–125, 2007.
- [8] J. Swaak and T. De Jong, "Discovery simulations and the assessment of intuitive knowledge," *Journal of Computer Assisted Learning*, vol. 17, no. 3, pp. 284–294, Dec. 2001.
- [9] M. Ebner and A. Holzinger, "Successful implementation of user-centered game based learning in higher education: An example from civil engineering," *Computers & Education*, vol. 49, no. 3, pp. 873–890, 2007.

- [10] D. Gillet, A. V. Nguyen Ngoc, and Y. Rekik, "Collaborative web-based experimentation in flexible engineering education," *IEEE Transactions on Education*, vol. 48, no. 4, pp. 696–704, Nov. 2005.
- [11] R. Lynn, C. Saldana, T. Kurfess, S. N. R. Kantareddy, T. Simpson, K. Jablokow, T. Tucker, S. Tedia, and C. Williams, "Toward Rapid Manufacturability Analysis Tools for Engineering Design Education," *Procedia Manufacturing*, vol. 5, no. 44th SME North American Manufacturing Research Conference (NAMRC 44), pp. 1183–1196, 2016.
- [12] S. Şeker, "Computer - Aided Learning in Engineering Education," *Procedia - Social and Behavioral Sciences*, vol. 83, pp. 739–742, 2013.
- [13] G. Bengu and W. Swart, "A computer-aided, total quality approach to manufacturing education in engineering," *IEEE Transactions on Education*, vol. 39, no. 3, pp. 415–422, 1996.
- [14] C. Koh, H. S. Tan, K. C. Tan, L. Fang, F. M. Fong, D. Kan, S. L. Lye, and M. L. Wee, "Investigating the Effect of 3D Simulation-Based Learning on the Motivation and Performance of Engineering Students," *Journal of Engineering Education*, vol. 99, no. 3, pp. 237–251, 2010.
- [15] Z. Wu, T. M. Tucker, C. Nath, T. R. Kurfess, and R. W. Vuduc, "Step Ring Based 3D Path Planning via GPU Simulation for Subtractive 3D Printing," *Journal of Manufacturing Science and Engineering*, vol. 139, no. March, pp. 1–10, 2016.
- [16] J. A. Tarbuton, T. R. Kurfess, and T. M. Tucker, "Graphics Based Path Planning for Multi-Axis Machine Tools," *Computer-Aided Design and Applications*, vol. 7, no. 6, 2010.
- [17] M. Hossain, T. Tucker, T. Kurfess, and R. Vuduc, "HDT: A Hybrid Structure for Extreme-Resolution 3D Sparse Data Modeling," *30th International Parallel and Distributed Processing Symposium (IPDPS)*. Chicago, IL, 2016.
- [18] R. Lynn, D. Contis, M. Hossain, N. Huang, T. Tucker, and T. Kurfess, "Extending Access to HPC Manufacturability Feedback Software through Hardware-Accelerated Virtualized Workstations," in *International Symposium on Flexible Automation (ISFA 2016)*, 2016.
- [19] R. Lynn, D. Contis, M. Hossain, N. Huang, T. Tucker, and T. Kurfess, "Voxel Model Surface Offsetting for Computer-Aided Manufacturing using Virtualized High-Performance Computing," *SME Journal Of Manufacturing Systems*, 2016.
- [20] TuckerInnovations, SculptPrint web site: <http://www.sculptprint3d.com>. Accessed 3.13.2017.