

## Experiences with an Introductory Electronics Course for Non-Science Majors

Biswajit Ray  
Dept. of Physics & Engineering Technology  
Bloomsburg University of Pennsylvania  
Bloomsburg, PA 17815

### Abstract

Experience with a hands-on introductory electronics course for non-science majors is presented. This three-credit course is offered as a general education science course with no physics or mathematics pre-requisite. Expectation of students varies from getting a basic understanding of electronics to building a television to learning new technology innovations and breakthroughs. The course becomes interesting to students only when the subject material is discussed in relation to real-world electronic gadgets as evidenced by the course-level assessment-improvement-verification feedback process. The course starts with basics of electricity and ends with microcomputer architecture, and encompasses significant hands-on circuit building and testing throughout the semester. Details on curriculum, assessment, laboratory exercises, teaching and laboratory methodologies, homework and textbook issues, and techniques that work as well as the ones that do not work are presented herein.

### Introduction

An introductory electronics course as a general education science course for non-science majors is in existence for some time at the Bloomsburg University of Pennsylvania. This course was recently revamped to make it more challenging and interesting to students supported by a course-level assessment-improvement-verification process. The interest level and background of students were taken into consideration in updating this course. Hands-on laboratory exercises and qualitative circuit analysis are supplemented with simple mathematical analysis as needed.

This three-credit introductory course is offered primarily to nonphysical science majors, and most students register to fulfill their general education science requirement. The semester-long course has no physics or mathematics requirement, and is open to students of any major and academic level. The objective of the course is to provide “theoretical and practical knowledge of electronic circuits, instruments and devices”. Hands-on experience in building and testing electronic circuits is an integral part of the course. The class typically meets for three 50-minute sessions per week. This course starts with an introduction to electricity and ends with microcomputer architecture.

The following sections present student background, course-level assessment approach, curriculum and laboratory methodology, textbook issues, student feedback, and DO's and DON'Ts in offering such a course. Since a good number of students in this course are undeclared freshmen, a job well done could potentially help in recruiting a few EET students.

## **Student Background and Expectation**

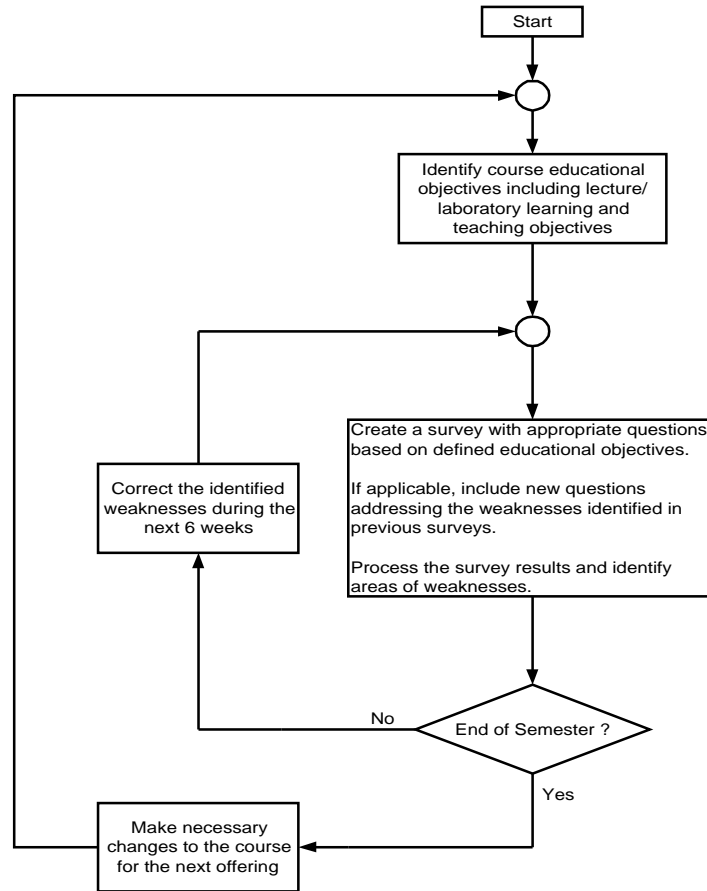
Students from freshman through senior levels come from a wide variety of majors including criminal justice, elementary education, secondary education, psychology, computer science, computer information systems, business management, marketing, history, special education, and undeclared. The primary motivation for registering in this course is to meet physical science general education requirement, albeit a few students sign up due to general interest in electronics mostly fueled by high school experience. The expectation of students out of this course at the beginning of the semester range from 'a basic understanding of electronics' to 'hands-on experience with electronics' to 'learn about new technology innovations and breakthroughs'.

## **Course Assessment**

A course-level assessment-improvement-verification feedback process<sup>1,2</sup> was implemented for students' classroom learning experience. Traditionally, assessments for measuring students learning experience are carried out only once at the end of each semester utilizing standardized institutional survey. This approach leads to long turn-around times in the assessment-improvement feedback loop. Assessment, improvement, and then verification that changes made to improve the learning experience were indeed effective can take up to two years for classes taught annually. Secondly, end of semester assessment results are specific to the group of students participating in the assessment. Since the learning experience can be very subjective, and class dynamics in a general education course for non-science majors vary significantly from semester to semester, course changes to improve learning experience which were based on an assessment taken at the end of a course may not be beneficial to students in future offerings. Finally, because traditional assessments are often based on an institutional standard, they do not address the students learning experience in light of course-specific educational objectives.

The shortcomings of using standardized end of semester assessments can be overcome by using a series of multiple short assessments during a semester, in which assessments are designed specifically for the course and the student body. This assessment-improvement feedback process flowchart is shown in Figure 1. This process substantially reduces the assessment-improvement-verification turn-around time, making it easier to determine the effectiveness of teaching or curriculum changes on the learning experience. It also addresses the problem of varying class dynamics since changes in course curriculum or the teaching style directly benefit those students participating in the assessment. The proposed assessment methodology also incorporates the active learning techniques<sup>3,4</sup> in a laboratory situation. The purpose of implementing active learning in this course is to cause the student to integrate and utilize the knowledge rather than to re-involve the student into the learning process after an extended period of inactive listening.

The learning and teaching objectives for the course are listed next. A list of questions was prepared based on the stated objectives, and the survey was conducted during the third, ninth, and fifteenth week of the semester.



**Figure 1 Assessment-improvement-verification feedback process flow chart**

Course Learning Objectives:

Appreciate the use of electronics in everyday life  
 Describe the difference between dc and ac electricity  
 Understand the relationship between analog and digital electronics  
 Distinguish the use of uncontrolled versus controlled electronic components  
 Establish the link between electronic components and systems  
 Explain how a computer works  
 Comfortably use basic electronic measuring instruments  
 Design, build, test and troubleshoot simple electronic circuits  
 Able to decipher useful information from manufacturer's specification sheet of electronic components and/or systems

Course Teaching Objectives:

Provide an enthusiastic environment for learning  
 Review basic mathematical skills  
 Involve students in lecture classes  
 Assign homework to reinforce the understanding of material covered in class  
 Use class time effectively  
 Encourage students to use the office hours for discussing academic and related non-academic issues  
 Make the presentation hands-on, and more qualitative than quantitative

## **Course Structure**

The course usually meets for three one-hour sessions per week, and two one-hour lecture sessions are typically followed by an one-hour lab session. Since students are mostly from non-science majors, a brief but focused review of scientific numbering system (powers of 10) and basic algebra skills at the beginning of the course is a must. A set of homework problems on mathematical skills review is found to be very effective. Thereafter, course starts with introducing basic electrical concepts and terminologies. The general teaching philosophy is to introduce a new circuit component, describe its terminal characteristics, take the part out of the lab kit and use it in a very simple circuit application, discuss basic concepts and mathematical skills needed to use the part in a design followed by a 50-minutes lab session on an application-oriented circuit building and testing incorporating the newly introduced part. The course is geared towards application oriented lab exercises, however, intuitive analysis skills are discussed before the lab session. Homework assignments are used to reinforce the theoretical concepts as well as intuitive analysis skills. Typical course content and laboratory exercises are listed below.

### **Typical course material**

- Mathematical skills review (powers of ten and basic algebra)
- Atomic structure of matters
- Electronic charge, current, voltage, and resistance
- Basic circuit laws (Ohm's law, KCL, and KVL) and resistive series-parallel circuits
- Capacitor properties, uses, and charging/discharging properties
- Semiconductor diode and its applications
- DC versus AC, concepts of amplitude and frequency, microphone/speaker operation, and household wiring scheme
- AC-DC rectification: integrate the use of resistor, capacitor, and diode
- Bipolar junction transistor terminal characteristics, and use as an amplifier and electronic switch
- Introduction to digital electronics, analog-versus-digital, CD recording/playing example, and binary-decimal number systems
- Basic logic gates: discrete (integration of resistors, diodes, and transistors) and integrated circuit
- Practical applications of logic gates
- Digital display (seven-segment) and BCD-to-7-segment decoding
- Flip-flops and counter operation and applications
- Design of a photoelectric counter (integration of resistors, capacitors, diodes, transistors, analog timer IC, and digital ICs including counter, decoder, and display)
- Introduction to computer architecture and operation: CPU, memory, I/O interfaces, data/address/control busses, and operating systems
- Opening up an up-to-date PC, and visual inspection of all major components and I/O interfaces

### **Typical laboratory experiments**

- Ohm's law using resistors and LEDs
- KCL/KVL and series-parallel circuits using resistors and LEDs
- Capacitor charging/discharging and time-constant
- DC and AC signals including the use of function generator, digital oscilloscope, and speaker
- Diode rectification
- Night-lamp using a BJT
- Discrete logic gate operation
- Digital display and decoder IC
- Photoelectric counter design

## Laboratory Setup

The laboratory has twelve stations to accommodate 24 students. However, the class size is limited to typically 20 students for this course to keep the 50-minute labs manageable. As shown in Figure 2, each station is equipped with a PC, a DMM, a dc power supply, a function generator, and a two-channel digital oscilloscope. Each pair of students is given a kit the first day of class for their use during the entire semester. Students are to keep the kit in the lab after each use. Contents of a typical kit are shown in Figure 3, whereas Table 1 lists the parts in a typical kit.

Students verify their kit against the parts list to make sure their kit is complete within the first two class meetings. This way they get to physically see and touch various types of parts they will be using during the semester. Additionally, this activity works as an icebreaker for a newly formed lab group and encourages a sense of ownership.

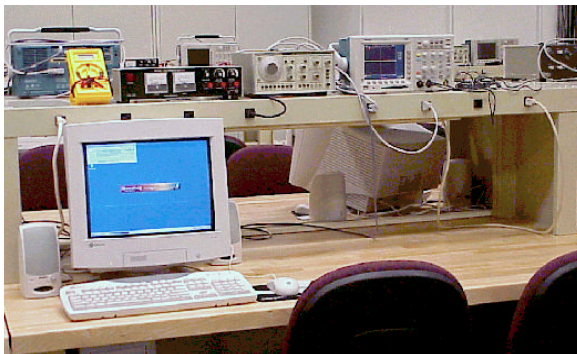


Figure 2 A typical lab station

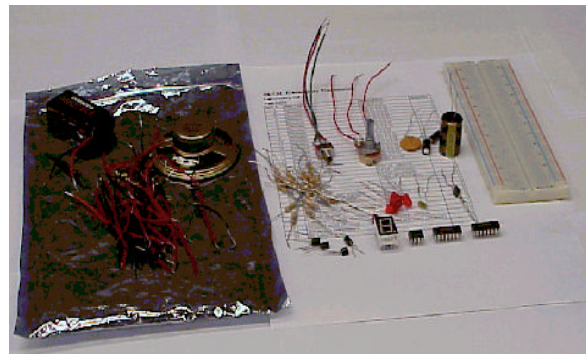


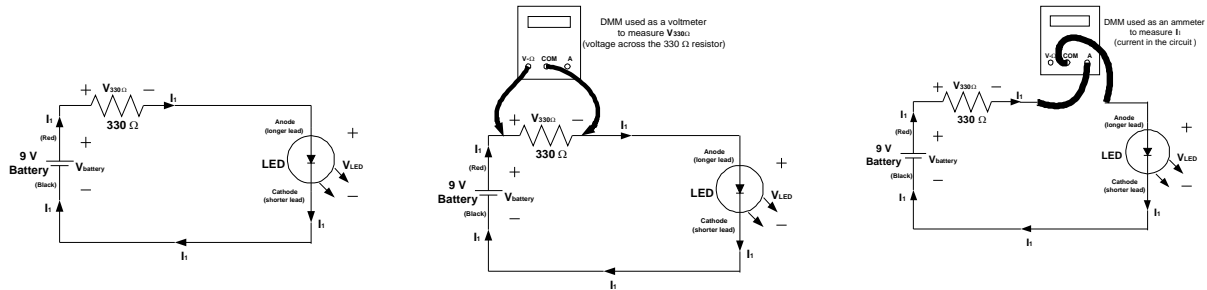
Figure 3 Parts in a typical kit

Table I Parts list for a typical lab kit

Item #	Part Type	Description	Quantity	Item #	Part Type	Description	Quantity
1	Resistor	47 $\Omega$ , 0.5 W	1	18	Capacitor	0.01 $\mu$ F, 50 V, ceramic	1
2	Resistor	180 $\Omega$ , 0.5 W	1	19	Capacitor	10 $\mu$ F, 35 V, electrolytic	1
3	Resistor	220 $\Omega$ , 0.5 W	1	20	Capacitor	47 $\mu$ F, 35 V, electrolytic	1
4	Resistor	270 $\Omega$ , 0.5 W	1	21	Capacitor	1000 $\mu$ F, 35 V, electrolytic	1
5	Resistor	330 $\Omega$ , 0.5 W	1	22	Mechanical switch	SPDT switch	1
6	Resistor	470 $\Omega$ , 0.5 W	1	23	Speaker	1 W, 8 $\Omega$	1
7	Resistor	510 $\Omega$ , 0.5 W	1	24	Diode	1N4003, 200 V, 1 A	2
8	Resistor	560 $\Omega$ , 0.5 W	10	25	Light emitting diode (LED)	Red, 25 mA, 1.8 V	5
9	Resistor	1 k $\Omega$ , 0.5 W	2	26	Transistor, bipolar, NPN	2N3904, 40V, 200 mA	2
10	Resistor	1.2 k $\Omega$ , 0.5 W	1	27	Analog timer IC, 8-pin	555	1
11	Resistor	1.5 k $\Omega$ , 0.5 W	1	28	BCD-to-seven segment decoder IC, 16-pin	CD4511	1
12	Resistor	4.7 k $\Omega$ , 0.5 W	1	29	Decade counter IC, 16-pin	CD4029	1
13	Resistor	10 k $\Omega$ , 0.5 W	2	30	7-segment display IC, 10-pin	Common cathode, 10 mA/2 V	1
14	Resistor	15 k $\Omega$ , 0.5 W	1	31	Stripped wires (4" long)	#22, red and black (20 each)	40
15	Resistor	33 k $\Omega$ , 0.5 W	2	32	Solderless breadboard	Includes two power strips	1
16	Potentiometer	100 k $\Omega$ , 0.5 W	1	33	9 V battery with battery-snap		1
17	Photoresistor	50 mW, 3 k $\Omega$ -20 k $\Omega$ /500 k $\Omega$	1	34	ESD-safe bag	6"X10" static-shielding zipbag	1

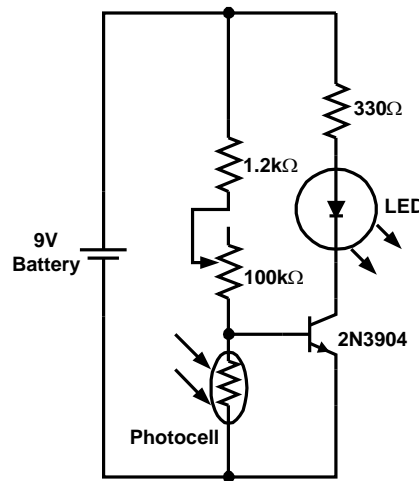
## Laboratory Experimentation Methodology

Most laboratory experiments are designed such that students can finish the exercise in 45 minutes for a standard 50-minute long class. One way to achieve this goal is to provide detailed diagrams showing how to take measurements in the lab. As an example, Figure 4 shows how to use a DMM to measure voltage across a circuit element and current through a circuit element within a simple series circuit used in the first lab experiment for the course. Also, having a LED in the circuit makes it interesting for the students to see it light up. Additionally, the intensity of the LED light can be used as an intuitive way of looking at voltage–current relationship in a circuit.



**Figure 4 Instructions for the first lab exercise on how to use a DMM to measure current and voltage in a circuit**

When a new circuit component is introduced in the class it is a prudent idea to have the students perform a lab exercise with the newly introduced part during the next class through an everyday application. For example, Figure 5 shows a simple battery operated night-lamp circuit incorporating a photocell and a LED used right after BJT is introduced as a new component. Through this experiment students are exposed not only to the use of a bipolar transistor as a switch but also to a photoelectric transducer via an application oriented circuit. Use of the 100 kΩ potentiometer is found very interesting by the students as they have to think through the process of calibrating the circuit operation to photocell's characteristics.



**Figure 5 A night-lamp design illustrating the use of BJT as a switch and photocell as a transducer**

The final hands-on experience for this course incorporates a project-oriented lab towards the end of the semester that uses all of the circuit components introduced in class. Typically, four consecutive 50-minute classes are used for the successful implementation and testing of a photoelectric counter. The design is broken into four sections as shown in Figure 6. Students start designing and building circuits from the back-end. During the first class period for this project students build and test the BCD-to-7-segment decoding and 7-segment display circuits as shown in Figure 7.

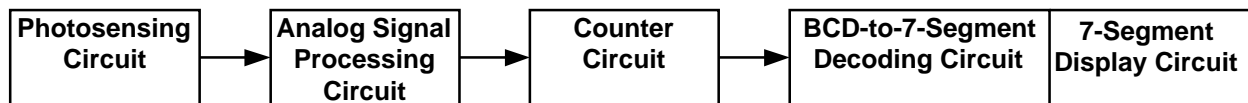


Figure 6 Design blocks for a photoelectric counter

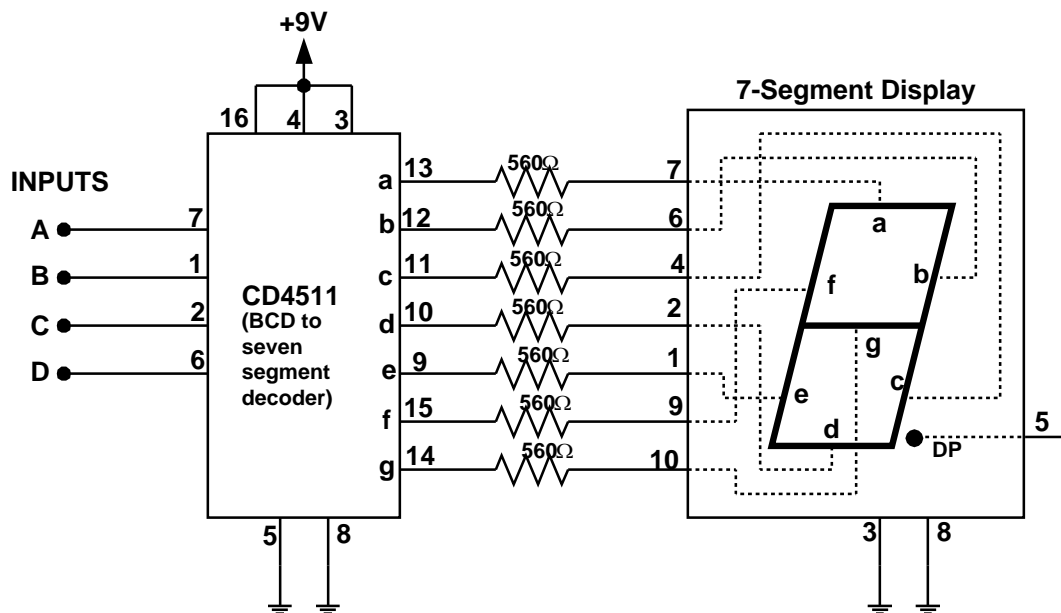
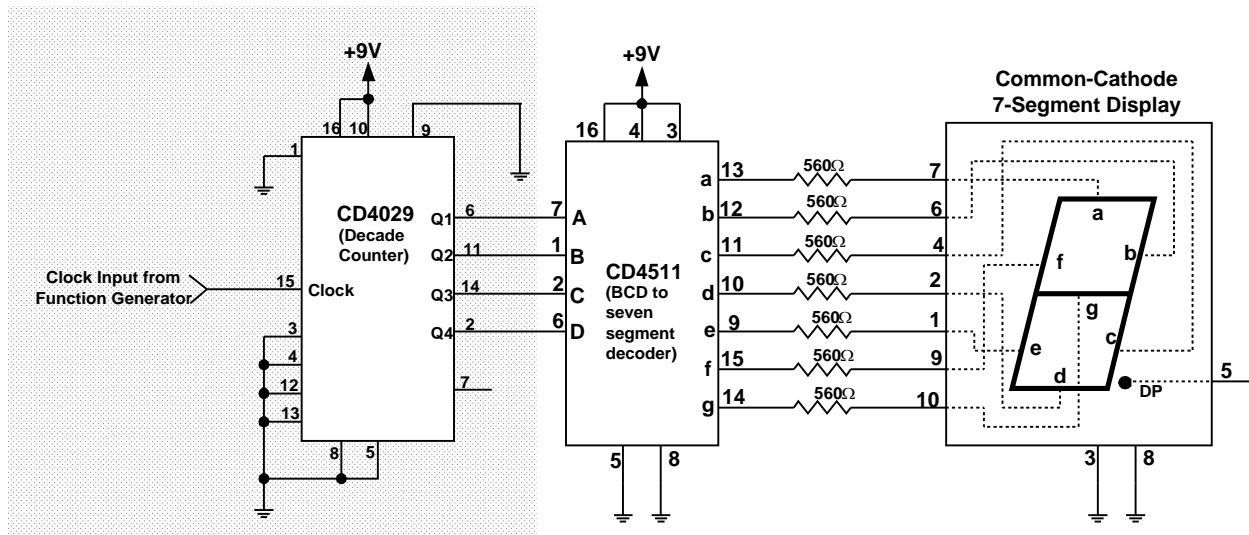


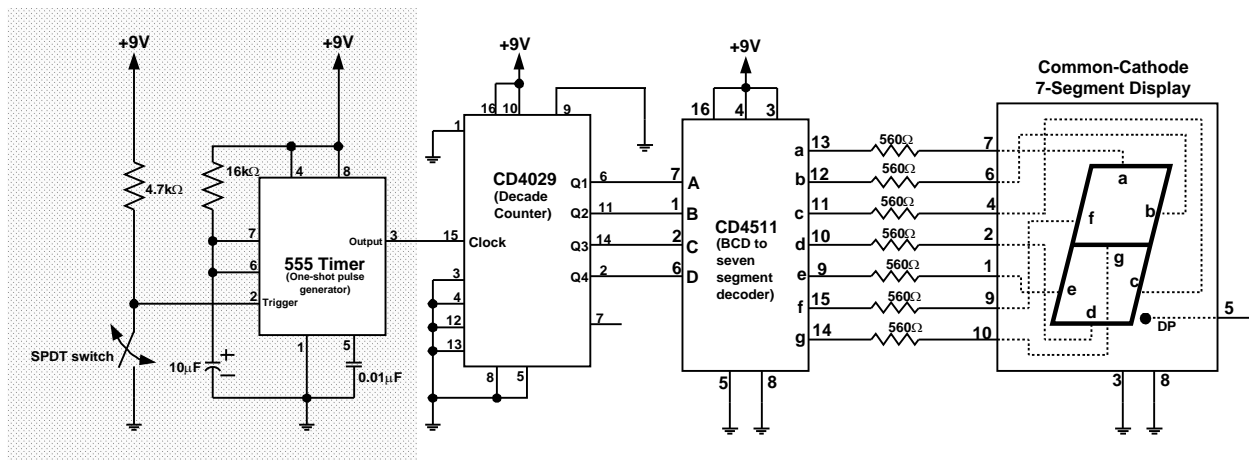
Figure 7 BCD-to-7-segment decoding and 7-segment display circuit

During the second class, students add-on the counter circuit shown in Figure 8 to the already built decoder/display circuit. With the aid of a digital scope, they test out the counter and display operation by inputting clock from a function generator. The next class, students add-on the 555 timer based analog signal processing circuit to the counter/decoder/display circuit as shown in Figure 9. They test out the counter/display operation by using a mechanical SPDT switch as the photo-sensing circuit output. During the fourth and final class for this project-oriented laboratory, students replace the mechanical SPDT switch by adding on the photo-sensing circuit as shown in Figure 10. The complete operation of the photoelectric counter is then tested by blocking/unblocking light onto the photo-resistor and monitoring signals at key points in the circuit with the aid of a digital scope.

This step-by-step approach to building and testing a relatively complex circuit for this course results in almost 100% success rate in completing the project, and leads to great satisfaction among students.

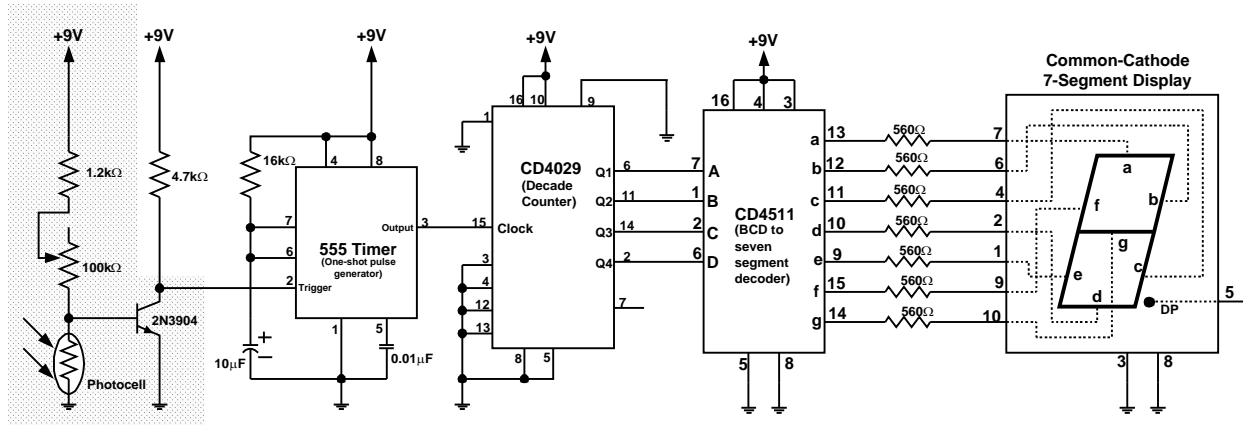


**Figure 8 Counter circuit added onto the decoding/display circuit**



**Figure 9 Analog signal processing circuit added onto the counter/decoder/display circuit**





**Figure 10 Finished circuit after adding the photo-sensing circuit onto the analog signal processing/counter/decoder/display circuit**

### Textbook Issues

There are a number of books covering only electricity (e.g., dc, ac, R, L, C, circuit analysis, etc.) or only electronics (e.g., diodes, transistors, op-amps, digital electronics, etc.). Their level of coverage is typically geared towards engineering/technology majors. A few electricity-electronics survey books are available that covers pretty much everything in electrical engineering domain. They are expensive and are usually not suitable as a text for an introductory course for non-science majors. Then there are a few inexpensive introductory books that are purely of trade/vocational nature with practically no analytical discussion. This scenario makes it difficult to find an appropriate textbook for a course such as the one presented here. A textbook survey was conducted during Spring-2001 through the ASEE-ETD listserv. The responses received are listed<sup>5-11</sup> in the bibliography. The book by Gates<sup>6</sup> is currently used as the text for the course with homework problem sets, detailed laboratory exercise handouts, and copies of lecture notes provided as supplemental materials.

### Student Feedback

Quantitative analysis of student feedback is not reportable at this stage. However, majority of students were pleased with the course structure. Qualitative feedback from students is presented below through their comments.

- ✓ Liked working with oscilloscopes and wave generators
- ✓ Enjoyed working with partner
- ✓ Applying classroom knowledge to real-world examples was interesting
- Writing lab reports was time consuming
- ✓ Great to have hands-on experience with electronic equipment
- Reliance on partner was a problem
- ✓ Very thorough, easy to follow laboratory instructions
- Include a little more in-depth lab experience
- ✓ Just getting to do a lab is fun
- Lab instructions are sometimes hard to understand
- Got a little bored when the class got slow.....when people were struggling with what I understood
- ✓ Very interesting course.....making me lean towards doing something in electronics
- This is not what I would call elementary electronics
- ✓ I found the course challenging and interesting
- Include computer-based measurements

## **DO's**

- Review of basic mathematical skills is a must.
- Weekly homework/pre-laboratory work goes a long way in reinforcing the theoretical concepts.
- Plenty of diagrams in the lab handout help in getting the labs completed on time.
- A good explanation on using the breadboard is a must. Tear up a breadboard, and let the students inspect how tin-plated copper run through the board.
- Qualitative/intuitive analysis supplemented by simple quantitative analysis is the way to go.
- Lab experiments need to be planned carefully such that lectures can be geared towards lab exercises while integrating the basic theory seamlessly.
- Hands-on group experience in building and testing application-oriented circuits is the major draw for a course like this.
- Integrate as many basic senses (lights, sound, touch, etc.) as possible into the experiments.
- Opportunity to use electronic instruments in the lab is a big attraction among students.

## **DON'Ts**

- Don't let the lab kits out of the class. Not all students will remember to bring their kits to every class. This also helps in not losing a few kits during the add/drop week.
- Don't plan on students' building circuits on their own outside the regular class hours. Teamwork is difficult to implement among resident and commuter students from various majors and multiple academic levels.
- Avoid students building a relatively complex circuit in its entirety, and then testing it. Go for the add-on approach and implement it through consecutive classes.
- Avoid detailed mathematical analysis and go for the intuitive/qualitative analysis.

## **Summary**

Experience with a hands-on introductory electronics course for non-science majors is presented. Curriculum and laboratory exercises need to be based on qualitative/intuitive approach supplemented by simple mathematical analysis. Laboratory experiments shall be designed around real-life applications, and realizable within a single or multiple consecutive class periods. Hands-on building and testing of circuits with the aid of standard electronic instruments is to be exploited in getting fundamental circuits and systems concepts across. Implementation of an assessment-improvement-verification loop directly helps the students involved in the assessment process.

## **Bibliography**

1. T. Rutar and G. Mason, "Short-term course assessment, improvement, and verification feedback loop," ASEE Annual Conference Proceedings, 2001.
2. D. A. Pape and P. L. Eddy, "Setup of a course level assessment for ABET 2000," ASEE Annual Conference Proceedings, 2000.
3. K. Nickels, "Do's and don'ts of introducing active learning techniques," ASEE Annual Conference Proceedings, 2000.
4. I. I. Orabi, "Outcomes assessment results of a multi-disciplinary first-year engineering course at the University of New Haven," ASEE Annual Conference Proceedings, 1999.
5. T. L. Floyd, "Electronics Fundamentals," 5th ed., Prentice Hall, 2001.
6. E. D. Gates, "Introduction to Electronics," 4th ed., Delmar, 2000.
7. B. Grob, "Basic Electronics," 8th ed., Glencoe-McGraw Hill, 1997.
8. Marchant, "Exploring Electricity," Prentice Hall.
9. Gerrish and Druggers, "Electricity and Electronics," Goodheart-Wilcox Company.
10. Mileaf, "Electricity one-seven," Hayden.
11. Bell, "Electric Circuits," 6th ed., David Bell Publishing.

## **BISWAJIT RAY**

Biswajit Ray is currently with the Electrical & Electronics Engineering Technology program at the Bloomsburg University of Pennsylvania. Previously, he taught within the Department of Electrical & Computer Engineering at the University of Puerto Rico – Mayaguez Campus. Dr. Ray also designed electronics for space applications for EMS Technologies, Norcross, GA. He received his B.E. degree from the University of Calcutta, M. Tech. Degree from the Indian Institute of Technology, Kanpur, and Ph.D. degree from the University of Toledo, OH.