



Experiences with Electric Circuit Analysis in a Blended Learning Model

Mr. Michael G. Morrow, University of Wisconsin, Madison

Michael G. Morrow, M.Eng.E.E., P.E., is a Faculty Associate in the Department of Electrical and Computer Engineering at the University of Wisconsin, Madison, WI. He previously taught at Boise State University and the U.S. Naval Academy. He is the founder and President of Educational DSP (eDSP), LLC, developing affordable DSP education solutions. He is a senior member of IEEE and a member of the ASEE.

Experiences with Electric Circuit Analysis in a Blended Learning Model

Introduction

This paper discusses the experience of implementing a new learning model in an introductory electric circuit analysis course. Historically, this course has been viewed as a “weed out” course; many faculty members considered a student’s ability to succeed in this course a strong and necessary indicator of future performance. However, it is reasonable to presume that some—or even many—of the students that struggled in this course did not lack ability, but instead had difficulties with the teaching/learning model employed in the course. It is a high-enrollment course that had been taught in a pure lecture format, and student work was done independently outside of class. While many students were in fact able to succeed in this environment, the approach had two serious shortcomings that needed to be addressed. First, students’ experience with the course dissuaded a number of them from continuing to pursue the discipline. Local studies on engineering student retention indicated that a significant number of those students were most likely quite capable of succeeding in engineering, but that they chose not to due to strong dissatisfaction in early course experiences. A second issue was the lack of content retention demonstrated by the students in later classes, where learned material had either been lost or severely degraded in a relatively short time. To address these problems, the electric circuit analysis course was converted a blended learning model in the Spring 2012 semester.

Overview

The term “blended learning” has been used to refer to a variety of pedagogical approaches to education that move beyond a simple in-person lecture to incorporate computer-based instruction and/or activities¹. For the purposes of this paper, the term “blended learning” is specifically defined as an instructional model where multiple modes of learning are used in the classroom, and in particular where the proportion of the course time spent in dedicated active-learning exercises is a significant fraction of the students’ total time spent on course activities. The particular approach described in this paper is better described as a hybrid learning model², since students still attend traditional lectures (as opposed to the flipped—or inverted—classroom model), but also participate in structured collaborative active-learning exercises. A more comprehensive discussion and literature survey of different forms of blended learning is outside of the scope and intent of this paper. Rather, this paper’s focus is to present experiences and data related to converting a particular course to a blended format, discuss the design and implementation of the related active learning exercises, and serve as a possible example for others contemplating similar course conversions.

In the conversion of the four-credit electric circuit analysis course, the topical content (covering both DC and AC circuits) remained the same. Previously, it was taught in a single section of four lectures per week, with typical enrollments of 80-100 students per semester. In the blended learning implementation, there is a single section with two lectures per week (Monday and Wednesday), and two collaborative active learning sessions per week (Tuesday and Thursday).

The reduction from four to two lectures per week necessitates streamlining of lecture content. Examples that were previously worked by the instructor during lecture (and easily forgotten by a large number of students) have been largely removed from lectures. Instead, the active learning exercises that replace half of the lectures provide a framework for students to work through various problems themselves, based on the theory that “doing” will facilitate deeper learning than “watching”.

The active learning exercises are held in a new purpose-built collaborative-learning facility, the Wisconsin Collaboratory for Enhanced Learning (WisCEL)³. Key features of WisCEL include an architectural design which encourages and enhances a collaborative learning atmosphere, along with the provisioning of technology to facilitate the deployment of large-scale learning activities. Students work at hexagonal tables with six seats, and each position has a laptop computer. Large video monitors are placed throughout the space to provide information to the students, which is necessary because the space is intentionally designed not to have a single focal point like a typical classroom.

The Moodle course management system⁴ is used as the delivery mechanism for active learning exercises, which students work through using the laptop computers provided in WisCEL. Moodle provides a framework for question design—including the use of randomized and calculated questions—and the ability to automatically grade student responses and provide them with immediate feedback. These features will be discussed in later sections, and are crucial to the success of this active learning format.

Implementation

Supporting the collaborative active learning component was the largest single challenge in the implementation. In order to motivate student participation, it is critical that the exercises be required work. A basic truism of education is that assessment drives learning. The “stakes” need to be high enough that students take the exercises seriously, yet low enough that they are willing to make mistakes and confront their misconceptions. Often, getting a question wrong can be even more instructive than figuring out how to get all of them right. Thus, the exercises should count “enough” to matter, but not be a major factor in determining a student’s grade. To help students better appreciate the importance of the exercises, they are reminded that an entire exercise contributes less to their grade than a single exam question—and that they would much rather get a question wrong on the exercise—*as long as they learn the material*.

Unfortunately, having graded exercises results in a potentially massive workload of 160-200 assignments per week. This is especially difficult under the constraint of providing timely (i.e. before the next exercise) feedback to students to help them better gauge what they understand well and what they may need to revisit. From the faculty point of view, evaluating overall student performance to observe trends and identify areas in need of reinforcement is a similarly daunting workload.

A second issue in implementing the collaborative learning environment is the need to ensure that each student is in fact participating in their learning process—not simply observing what their neighbors are doing and copying answers. This means that the exercises cannot be identical for each student, but should be similar enough to encourage collaboration and peer teaching.

Both of the above issues were addressed by the integration of technology. The Moodle course management system was used to deliver active learning exercises, provide automated assessment of student responses and immediate feedback, and allow easy faculty access to class performance data. Rather than simply being a delivery mechanism, Moodle became the focal point of course activities. The course pedagogy is also shaped by the capabilities of the technology. The technology makes many things possible that would simply be unworkable in a lecture setting. By designing pedagogy to take maximum advantage of the technology, a better learning environment can be created for the student.

Exercise Design Philosophy

Inherent in the shift to the blended-learning model was the recognition that, for most students in this course, the active learning exercises would now be the dominant mechanism for learning. Active learning exercises are not (and should not be) typical homework problems, which are normally a summative assessment tool. Instead, the exercises are intended to help students learn by guiding them through the concepts and connections that make up the topical knowledge, and preparing them to apply that knowledge in increasingly complex situations. The design of the active learning exercises was by far the majority of the workload in making the transition, and was guided by several pedagogical principles:

- a. Use technology only if it helps student learning or helps the faculty teach better. While this may seem obvious to many, it is important to remember that technology is just the vehicle, not the payload.
- b. Frame exercises as places to generate *teaching opportunities*, not as examinations. Getting students to feel comfortable asking questions changes the game so that students are now “pulling” information, instead of the instructor “pushing” it.
- c. Create exercises that serve as learning scaffolds, and maximize the opportunities for peer teaching. In addition to the positive benefits of peer teaching for the students, this also reduces the demand for instructor assistance during the exercises.
- d. Provide immediate feedback to students to allow them to gauge their performance in real-time. Also give students the opportunity to retry problems that they missed, to help ensure that they have actually learned the material, and to combat the notion that once they have completed a question, even if it is wrong, it “no longer matters”. In Moodle, this is achieved using the “interactive, multiple try” feedback mode, where students have multiple opportunities to answer a question, usually with some score reduction per answer attempt.
- e. Encourage collaboration, but require individual work and results. Exercises should make students want to talk about how to approach problems, but still require them to do their own work. By making some problems in an exercise identical for all students, opportunities for collaboration and peer teaching are created. By making other problems in the exercise different for each student, it ensures that students actually have to do the work for their problem.
- f. Start by exercising single concepts. Since much of the active learning occurs when a student’s conceptual knowledge is formative at best, getting them to understand a basic concept well is imperative. By building a solid conceptual foundation, this improves the

students' ability to teach themselves (and each other) more advanced material and minimize their misconceptions.

- g. Avoid overly-complex problems. Simple problems are often the best path for students to make higher-level connections. Exercises should strive to deliver “a-ha” moments, where the proverbial light bulb comes on for a student when they make a conceptual connection.
- h. Use targeted problems to directly illuminate common student misconceptions. When student misconceptions are identified, or proactively anticipated, exercises are designed specifically to get students to see what the issue is and why it is a misconception. In Moodle, feedback can also be given to students who enter incorrect answers by setting up a specific feedback item for anticipated erroneous responses.
- i. Get students to think about causality and relationships, not just rote numeric procedure. By interspersing qualitative questions (including concept questions, what-if scenarios, etc.), students are led to see and appreciate the meaning underlying the equations and processes that they use.

Examples of collaborative exercise questions that illustrate the pedagogical concepts listed above will be discussed in the paper presentation, and a sample set is included as Appendix A

Assessment of the Blended Learning Implementation

The performance of the blended learning implementation of the electric circuit analysis course was analyzed along two dimensions. First, student performance in the course was compared to the previous semester when it was taught as a traditional lecture course by the same instructor. The exams in both semesters were comparable in difficulty, and analysis of the student populations showed no significant differences between them. Students demonstrated significantly better performance in the blended version of the course, as shown in Figure 1. A marked change in the distribution of student grades was also observed, with the number of marginal and poorly performing students significantly reduced.

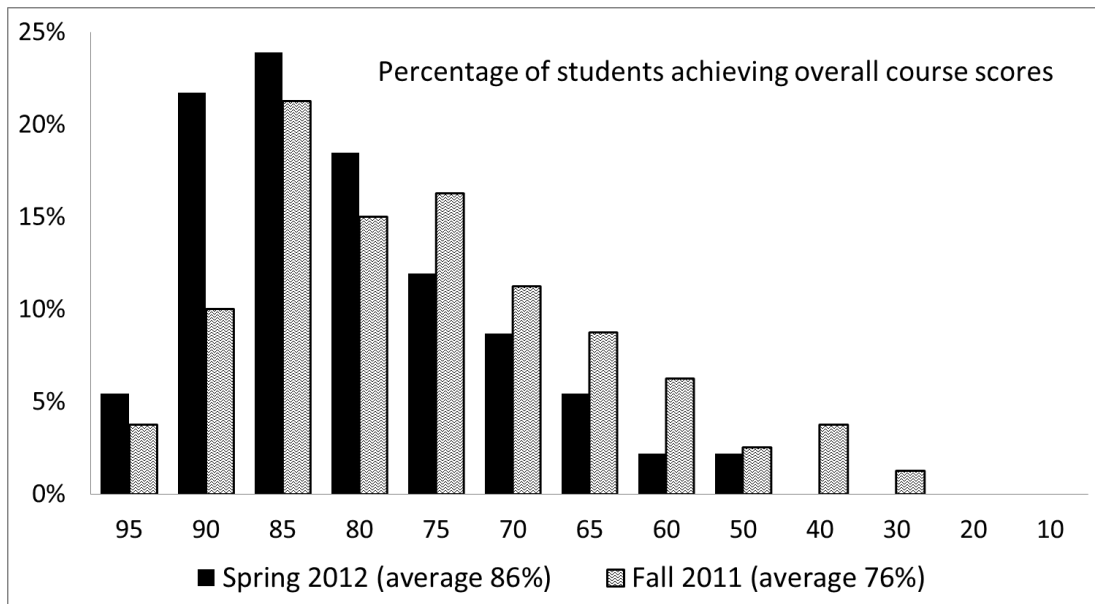

Figure 1

Secondly, students in the course were surveyed to gauge the course's effect on improving student satisfaction, and to help refine the learning model in future iterations. Students who took the pilot version of the electric circuit analysis course (ECE 230) in Spring 2012, and a refined version in Fall 2012, completed identical surveys in which they compared ECE 230 to other STEM courses they had taken of similar scope and difficulty. Since many students enter the university with advanced placement credit in the prerequisite physics and calculus courses, having the students use a specific comparison course was not possible. Instead, they were asked to select a course that they felt was similar, and use that as a reference. The prerequisite physics course and other ECE courses were most commonly reported by students as their comparison course.

As shown in Table 1, students noticed how the instructional design and pedagogy of ECE 230 differed from that of their comparison classes. Students perceived the WisCEL version of the course as placing much more emphasis on instructional practices, such as discussing course content with instructors and time devoted to solving problems or exercises during class meetings. Students perceived the WisCEL version placed "less" emphasis on practices such as doing exercises or problems outside of class, and working on the class by oneself. Students further perceived that the WisCEL environment made it easier to discuss course content with instructors and peers, that their WisCEL instructors cared more about student learning, and that their own level interest in the course and success in learning course content was higher.

Table 1

<i>For each item select the response that best represents the extent to which you feel ECE 230 or your Comparison Course rates "Greater/Higher," or "About the Same " in ECE 230 and the Comparison Course (i.e., to indicate that you spend more time on something in ECE 230 than your Comparison Course, select "Greater/Higher in ECE 230").</i>						
	Greater/Higher in ECE 230		About the Same in ECE 230 and Comparison Course		Greater/Higher in Comparison Course	
	Spring	Fall	Spring	Fall	Spring	Fall
The amount of time you discuss course content directly with instructors.	64*	67	32	23	04	08
Your level of comfort discussing course content with the instructor.	63	70	33	26	04	04
How much the instructors care whether you learn the course content.	69	63	29	37	02	00
Your level of comfort discussing course content with other students.	72	64	26	32	02	04
The degree to which working with other students increases your learning.	74	83	20	14	05	03
The amount of time devoted to solving problems during class meetings.	72	65	16	24	13	08
The amount of time devoted to solving problems in the course as a whole.	72	59	16	29	13	12
The amount of time you spend on the course outside of scheduled class periods (i.e., for homework and studying.)	20	26	38	31	43	43
The amount of time you work on the course by yourself.	18	29	34	32	48	38
How excited you feel to come to class.	59	65	29	30	13	5
Your level of interest in the course.	61	55	30	36	09	10
Your level of success in learning the course content.	64	53	32	36	04	10

*Percentage of students choosing a given response. The anonymous survey was completed by 56 of 91 (62%) of Spring 2013 students, and 66 of 82 (80%) Fall 2013 students.

In addition to taking notice of the innovative pedagogy and instructional design of the blended learning implementation of the class, survey respondents preferred the class as conducted in WisCEL. A total of 113 students responded to an open-ended survey item that asked them to briefly explain what they liked or thought was working well in the classes held in the WisCEL facility. Results for this item are combined for both blended semesters (Spring and Fall 2012) because response patterns differed little between the two groups. Of the 113 respondents, 61 (54%) said they liked how the blended class fostered peer collaboration, 60 (53%) liked the emphasis on working problems in class, and 25 (22%) appreciated having instructors ready to help with difficult problems.

Of the 113 students who volunteered liking one or more things about the WisCEL classes, 39 (35%) explicitly stated that the thing or things they liked resulted in more effective learning, 23 (20%) strongly implied the liked practices led to enhanced learning, and 23 (20%) simply stated

their preference without elaboration. A significant number of students volunteered details about why or in what way the collaborative exercises were especially supportive of learning. This includes 12 students who acknowledged that working on problems in class with peers and instructors made them “keep up” with the class instead of putting off serious studying until just before exams, 15 students who noted that the collaborative exercises were especially conducive to developing conceptual understanding, and 9 who noted that the class format was particularly good at preparing them to apply their knowledge beyond the classroom.

Three students captured themes sounded frequently in the broader sample when they said,

Working together on the homework is very helpful, but each person still submits their own quiz and therefore does their own work. Personally, I learn best when applying the concepts, so the computerized classroom is really a great way to learn and to retain information on how to approach and solve similar problems.

And,

[I like] the fact that we can work with other students to do the various questions in the on line quizzes. The quizzes are not difficult, but being able to collaborate with students makes it easier to understand concepts which are fundamental. I also like being able to ask the professor and T.A.s questions directly and having them be willing to help and give clear answers.

And,

I think that WisCEL is allowing us to better explore multiple approaches to problems by discussing our problem solving methods with others.

Electronic Examinations

Part of the planned course evolution was the introduction of electronic examinations. In the Fall 2012 offering, the final examination was conducted electronically using Moodle as the delivery vehicle. Starting in Spring 2013, all examinations (two midterm and the final) were conducted electronically. Most exam questions use randomized parameter values to minimize the potential for copying. Furthermore, during exams the WisCEL space is converted from a collaborative environment into a proctored electronic exam environment by using inexpensive cardboard carrels to visually separate each student’s table space from the others’. The carrels also minimize the students’ distraction of having to be careful to NOT look at their neighbors’ work.

Students are provided with a paper exam copy on which to do their work, but enter their answers into Moodle for automatic evaluation. The use of immediate feedback in the exam, combined with multiple tries on most questions, provides an opportunity for students to achieve partial credit. This eliminates the all too common student exam response of “I don’t know how to do this problem so I’ll write down everything I know and hope for partial credit” and instead awards credit to students who can recover from a mistake and demonstrate that they do, in fact, understand the material. In multi-part problems, students know that their answer on each part is correct (or what the correct answer is) before proceeding to the next part, so there are no issues

with errors carried forward. Students are allowed up to three tries for each response, with a 25% penalty assessed on each try.

Each question on the Fall 2013 final exam was analyzed to determine on which try students answered correctly. For all responses on the exam, 73.85% were correct on the first try, 11.73% were correct on the second try, 2.52% were correct on the third try, and 10.12% were incorrect on the third try. No attempt was recorded for 1.79% of the responses. The data for each multiple-try question on the exam is shown in Figure 2. Note that even on the more difficult questions (i.e. those with a low percentage correct on the first try), a significant fraction of the students whose first try is incorrect are able to recover and receive partial credit for the question.

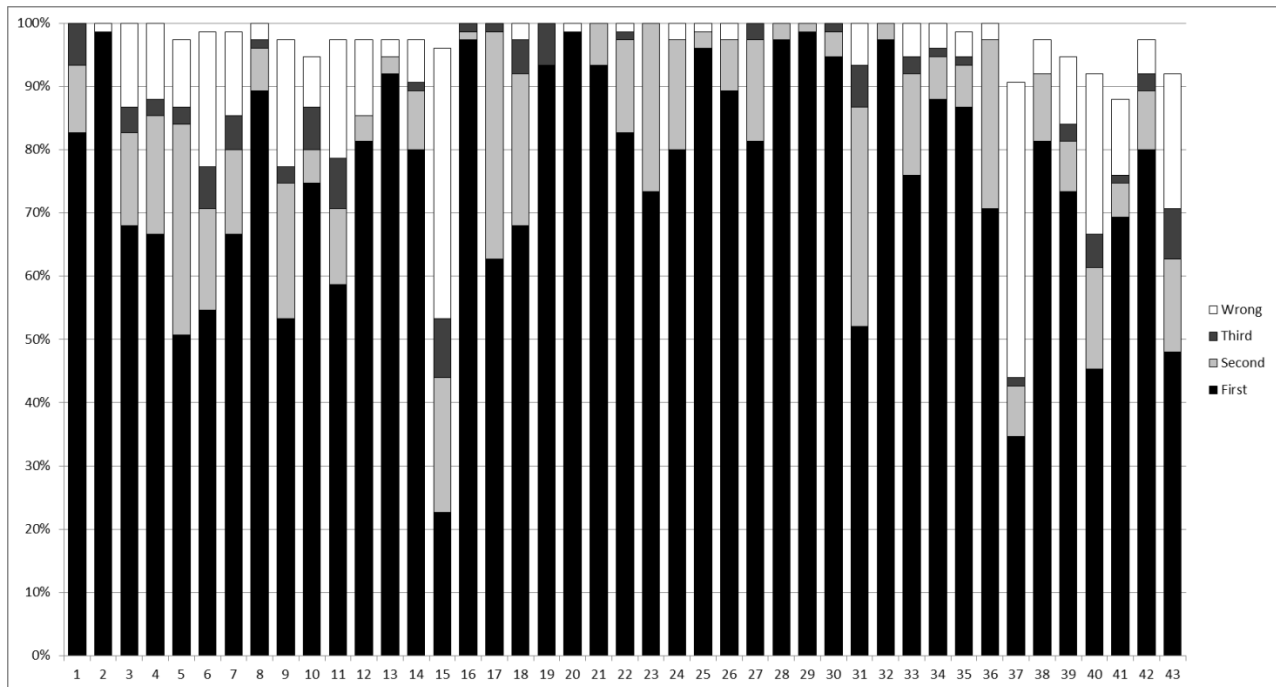

Figure 2: Per-question aggregated statistics showing the percentage of students entering the correct (subdivided into correct on the first, second, and third tries) or wrong (incorrect on the third attempt) answer.

An electronic exam with immediate feedback is a significant departure from students' usual exam experience, but they adapt to it quite well, and in fact *prefer* it to the traditional paper exam. Students were asked to complete a short survey after the final exam in Spring and Fall 2013. The combined results of the survey for both semesters are shown in Figure 3.

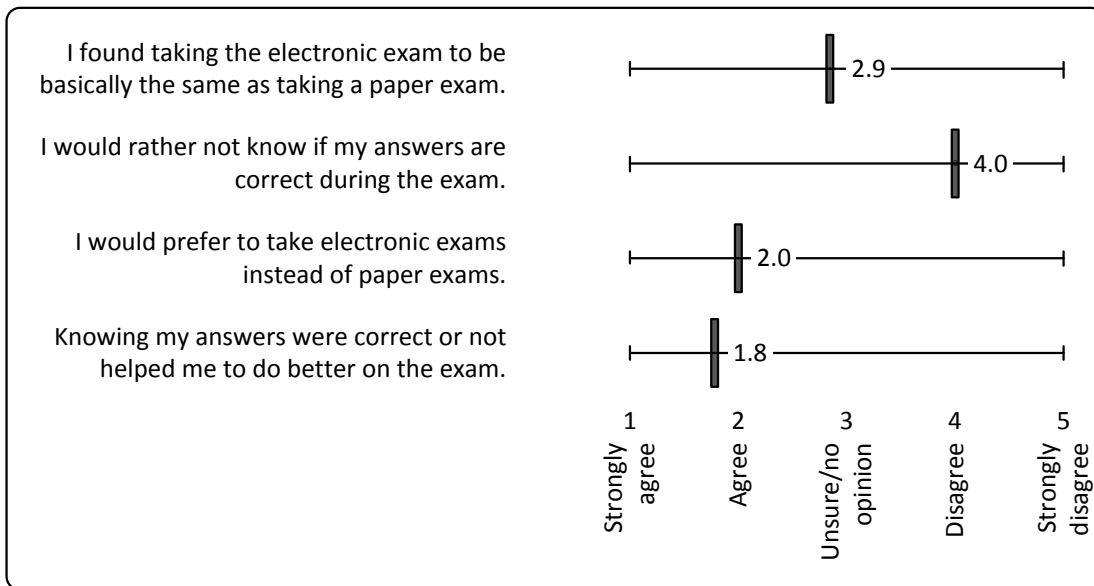

Figure 3: Aggregated student responses to electronic exam survey

Summary and Evolution

The single most important point in implementing a technology-enhanced course is the recognition that the technology is now a mission-critical resource. This point needs to be acknowledged and acted on by the organizations responsible for the technologies used. Although there were only a few technology-related disruptions in the two years that the course has been offered in the blended format, it is important to have contingency plans in place in the event of network outages, server failures, etc. For the twice-weekly active learning sessions, the penalty of an outage is minimal, and having the students independently complete the exercise later in the day is an adequate solution. For the electronic exams, the penalty is obviously much higher, so the exams are conducted with a very low-technology back up at the ready. In addition to the paper copies that students use for their work, a set of default values for the problems is printed and ready to distribute in case of a technology failure, which would result in a reasonably seamless reversion to a traditional paper exam.

The second major point is that converting a course to a technology-enhanced blended learning format is a *very* significant undertaking, and needs to be viewed as a long-term investment. The development of effective collaborative learning exercises requires a sound knowledge of the technology's capabilities and limitations, and a lot of creativity to craft ways to achieve the course's pedagogical goals within that framework.

The changes made to the course represent a significant body of work that is now reused and incrementally improved on in each offering. One area of continued work is the development of more practice exercises that students can use outside of class to improve (and self-assess) their understanding of course concepts. Another potential area for improvement is to develop online materials to replace the current two traditional lectures per week. However, this needs more pilot development and assessment to determine if it would be beneficial for students or not. Online materials were developed to replace a few of the course's lectures, and informal student surveys

in the course show that students generally preferred the in-person lecture to the online materials (in both cases presented by the same instructor).

Through the use of technology, the required teaching assistant (TA) and grader support were reduced. The conventional lecture-only course was normally taught with a full-time TA appointment while requiring 100+ hours of grader support per semester. The current course implementation operates very well with a half-time TA appointment and no grader support at all. As more courses have been converted to the blended format, sharing TAs between courses has become practical. This allows more TAs to be present in each active learning session, while the overall TA demand is kept constant or even decreased. Even though the TAs are being asked to support multiple courses, there is only a minimal increase in their preparation time for each course since they are not preparing a lesson, but only need to review the exercises for each session.

The course assessment data clearly shows marked improvement in student knowledge, with a simultaneous increase in student satisfaction. By having students learn better in a fundamentals course, their improved performance should ripple through the degree programs served by the course, and improve the experience of students and faculty alike in follow-on courses. The conversion of the electric circuit analysis course has been a success, and continued evolution will continue to enhance student learning while providing a more satisfying experience for students and faculty.

References

- [1] C. J. Bonk, C. R. Graham, *The Handbook of Blended Learning: Global Perspectives, Local Designs*, Pfeiffer, San Francisco, 2006.
- [2] J. A. Snart, *Hybrid Learning: The Perils and Promise of Blended Online and Face-to-Face Instruction in Higher Education*, Praeger, Santa Barbara, 2010.
- [3] University of Wisconsin-Madison, Wisconsin Collaboratory for Enhanced Education
<https://www.wiscel.wisc.edu/index.htm>
- [4] Moodle Pty Ltd (AU), Moodle, <https://moodle.org/>

APPENDIX A: Examples of Collaborative Exercise Questions

Example 1:

“Simple questions are often the best path to making higher-level connections”

Students are asked to use superposition with the simplest circuit possible. Often, students who can apply the concept of superposition to a more complex circuit will struggle with this problem, because they are following a process without truly understanding why. A similar problem with the three elements in parallel is presented to them as well.

Using superposition in the circuit below, find v (in V) if $V_x = 5$, $I_x = 4$, and $R = 1\Omega$. Check your results using basic circuit theory.

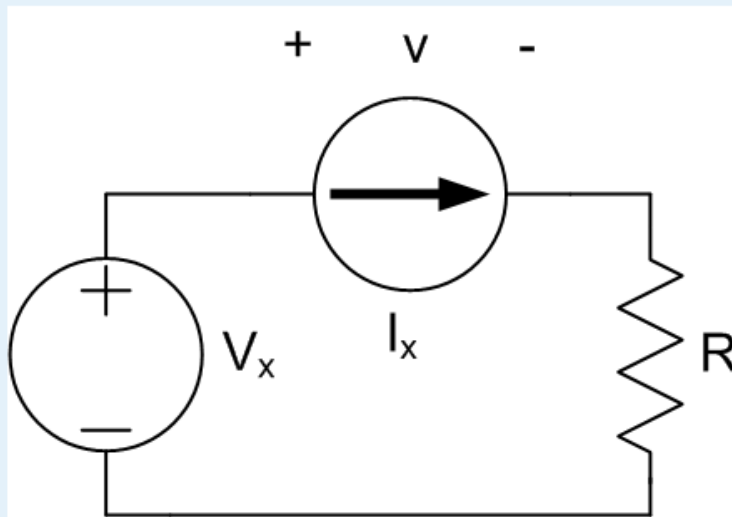

Answer:

Example 2:

“Get students to think about causality and relationships, not just rote numeric procedure.”

In this exercise, students are usually able to remember that best power transfer occurs when $R_L = R_1$, and can then calculate the power dissipated by R_L . However, when then asked to evaluate qualitatively what happens throughout the circuit when one element of the circuit is changed, they usually have much more difficulty. This exposes weaknesses in their understanding, and creates the opportunity to remediate that through peer teaching and instructor assistance.

For the questions on this page, refer to the circuit below. Assume $I_S = 4.1\text{A}$ and $R_1 = 22\Omega$.

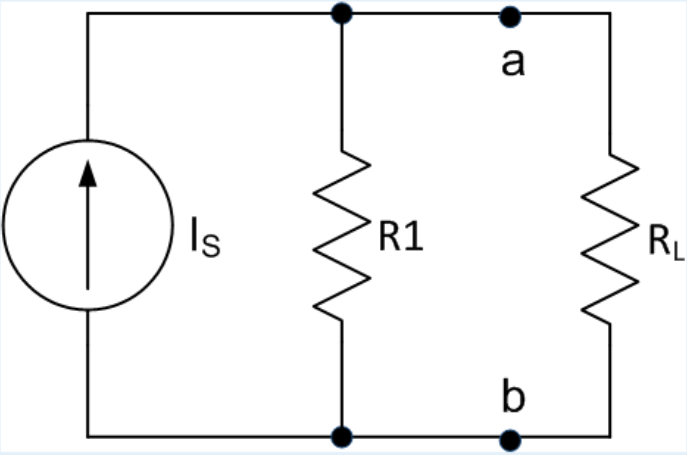

What value of load resistor R_L (in Ω) would dissipate the most power?

Answer:

What is the maximum power (in W) that could be delivered to a load resistor connected to this circuit?

Answer:

If the resistance of the load resistor R_L was decreased from the value that resulted in maximum power transfer, what would happen?

The current through R_L would _____.

The voltage drop across R_L would _____.

The power absorbed by R_L would _____.

The power supplied by I_S would _____.

The power absorbed by R_1 would _____.

Example 3:

“Exercises should make students want to talk about how to approach problems...”, “Use targeted problems to directly illuminate common student misconceptions.”

This question is intended to encourage peer discussion by asking thought provoking questions that require them to examine a relatively simple problem from different viewpoints. It also directly targets a common student misconception regarding maximum power transfer, where they often have a knee-jerk reaction to always make the two resistors equal for maximum power transfer regardless of the correctness of that approach.

A voltage source, a 5Ω variable resistor R_1 , and a 3Ω fixed resistor R_2 are connected as shown below. (Note that this connection of a variable resistor to form a two-terminal variable resistor is sometimes called a *rheostat*, and allows the effective resistance of R_1 to be set anywhere between 0Ω and 5Ω .) Match each question with the best response.

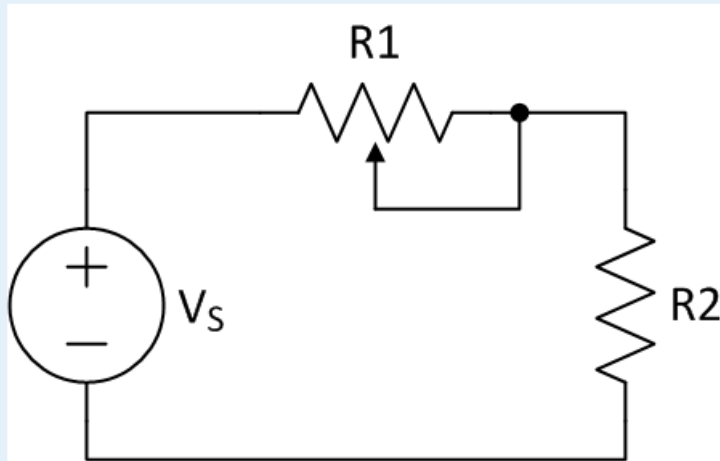

What effective resistance of R_1 will result in R_2 dissipating the **most** power?

What effective resistance of R_1 will result in R_2 dissipating the **least** power?

What effective resistance of R_1 will result in R_1 dissipating the **most** power?

What effective resistance of R_1 will result in R_1 dissipating the **least** power?

Choose...
Choose...
3
4
1
0
2
5

Example 4:

“Exercises should serve as learning scaffolds...”

Successfully applying many circuit analysis techniques requires not only a high-level understanding of the techniques, but also correctness in detail. This exercise is the student’s first introduction to applying the nodal analysis technique, so it is designed to lead them through the process. By providing multiple checkpoints along the way, errors in the student’s understanding of how to apply the technique are highlighted early.

Question 2
Tries remaining: 1
Marked out of 1.00
Flag question
Edit question

For the questions on this page, consider the circuit shown below. You are to use the nodal analysis method to solve for circuit parameters. Use worksheet #1 to organize your work. Assume $R_1 = 2\Omega$, $R_2 = 4\Omega$, $R_3 = 4\Omega$, $I_{S1} = 9A$, and $I_{S2} = 6A$. Enter these values on your worksheet.

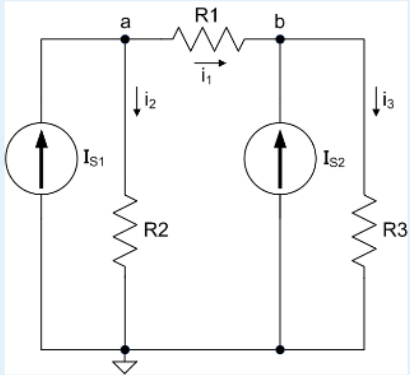

Not counting the reference node, how many nodes does this circuit have?

Answer:

Check

Question 3
Tries remaining: 1
Marked out of 2.00
Flag question
Edit question

The first steps in nodal analysis are to

- assign a reference node
- label the remaining nodes
- label all branch currents and assume a direction, and
- mark all resistor voltage polarities based on the assumed current directions.

Then, write KCL equations at each node (except the reference node).
Complete the KCL equation for node a by selecting the correct operators.

I_{S1} i_1 $i_2 = 0A$

Check

Question 4
Tries remaining: 1
Marked out of 2.00
Flag question
Edit question

Complete the KCL equation for node b by selecting the correct operators.

I_{S2} i_1 $i_3 = 0A$

Check

Question 5
Tries remaining: 1
Marked out of 2.00
Flag question
Edit question

The next step uses Ohm's law to rewrite all resistor currents in terms of node voltages and resistances.
Complete the KCL equation for node a.

/ R_1 + / $R_2 = I_{S1}$

Check

Question 6
Complete the KCL equation for node b.

Example 5:

“Use targeted problems to directly illuminate common student misconceptions.”

This sequence of two problems is used to highlight a common problem where students fail to apply Ohm’s Law correctly under a very specific situation, where an assumed voltage polarity is opposite the assumed current direction. By having to students confront this problem in isolation, they are better prepared to deal with it in more complex problems.

A fragment of a larger circuit is shown below. Which of the following equations are correct KVL equations for the i_2 mesh? Select all correct answers.

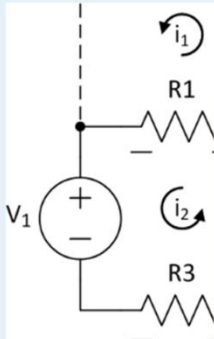

Select one or more:

- a. $V_{R1} + V_{R2} + V_{R3} + V_1 = 0$
- b. $-V_1 - V_{R1} - V_{R2} + V_{R3} = 0$
- c. $V_1 - V_{R1} - V_{R2} - V_{R3} = 0V$

A fragment of a larger circuit is shown below. Which of the following equations are correct KVL equations for the i_2 mesh? Select all correct answers.

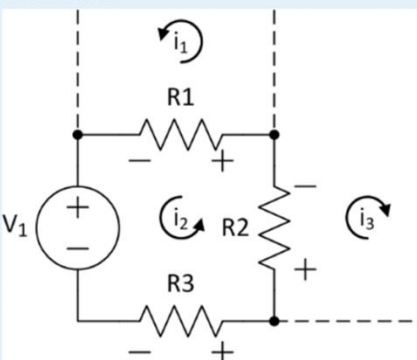

Select one or more:

- a. $(i_1 - i_2)R1 - (i_3 + i_2)R2 - i_2R3 = V_1$
- b. $(i_2 - i_1)R1 - (i_3 + i_2)R2 - i_2R3 = V_1$
- c. $(i_1 - i_2)R1 - (i_3 + i_2)R2 + i_2R3 = V_1$
- d. $(i_2 - i_1)R1 - (i_3 + i_2)R2 + i_2R3 = V_1$

Example 6:

“Exercise single concepts.”

In this series of questions (only part of the series is shown), the basic concepts at work in a first order circuit are explored individually, rather than asking for just the final solution. The second question in the series is not something commonly asked in this type of problem, but acts to reinforce their basic understanding of capacitor behavior.

For the questions on this page, consider the circuit shown below. Assume $V_x = 48\text{V}$, $R_1 = 4\Omega$, $R_2 = 3\Omega$, and $C = 0.25\text{F}$.

The switch has been closed for a long time and is opened at time $t=0\text{s}$.

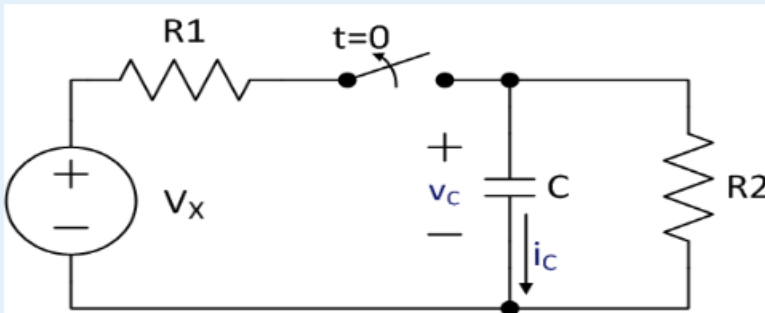

What is the capacitor voltage v_c (in V) immediately after the switch is opened?

Answer:

What is the capacitor current i_c (in A) immediately after the switch is opened?

Answer:

What is the time constant (in s) after the switch is opened?

Answer:

What is the capacitor voltage v_c (in V) after the switch has been opened for 0.6s?

Answer: