

Fostering Senior Design Projects that Change Lives

Ken Rennels, Marvin Needler, Dr. Chuck Dietzen, M.D., Patricia Fox, Scott Blackwell, Michael Venne, Lisa Hickman-Lause, Paula Jenkins-Williams, Elaine Cooney, Robert Herman

Indiana University Purdue University Indianapolis/Timmy Foundation

A few years ago, an engineering student recovering from leukemia found himself in a conversation with his doctor on how engineering and engineering technology students could use their talents to help children with special needs. That conversation started a relationship with the Chief of Staff at St. Vincent Children's Specialty Hospital in Indianapolis and the Purdue School of Engineering and Technology at Indiana University Purdue University Indianapolis (IUPUI). The result was a life-changing event for a little boy named Ian Farrar. This paper will discuss that project in length and ways in which other schools or institutions can foster relationships in their community that make a difference in someone's life.

Background

Ian Farrar was born in 1993 with severe physical disabilities and was given a life expectancy of only a few minutes. However, blessed with a tremendous spirit and will to live, Ian did survive and turned 8 years old in December 2001. Ian has been diagnosed with holoprosencephaly (failure of the forebrain to divide into hemispheres or lobes), hydrocephalus (excessive accumulation of fluid causing an enlargement of the cranium and atrophy of the brain), maladroon syndrome, cranial facial disorder and diabetes insipidus. These physical handicaps have left Ian with partially developed limbs and an enlarged head. At age 7, Ian was not able to walk, instead moving by rolling or scooting.

Ian came to the attention of students and faculty of the Purdue School of Engineering and Technology at IUPUI through contact with Dr. Chuck Dietzen, M.D. who at the time was the Chief of Staff at St. Vincent Children's Specialty Hospital in Indianapolis. Dr. Chuck, as his patients know him, was introduced to the school by an Electrical Engineering major at IUPUI and a patient of Dr. Chuck while recovering from leukemia. Dr. Dietzen was asked and joined the Dean's Industrial Advisory Committee (DIAC) and became an active member. Dr. Dietzen identified several children and young adults with severe physical challenges who could benefit from specialized engineering design of life-enhancing devices.

Jeep Design Project

When approached by faculty, Electrical Engineering Technology senior Mike Venne¹ and Mechanical Engineering Technology senior Scott Blackwell² readily agreed to a joint, interdisciplinary senior design to give Ian Farrar mobility. These two students met with Ian and

Dr. Dietzen in order to observe Ian's capability in controlling a vehicle and the necessary support needed in order for him to safely position himself in a vehicle. It was noted that while Ian was able to move himself on the floor, he had difficulty in supporting himself in a sitting position. Ian, however, did have a strong grip in his right hand and was able to control movement of his right arm and hand. It was determined that Ian should be able to control the vehicle with a joystick control with his right hand. Seating would have to be able to support Ian's head that represented approximately 40% of his body weight and support his arm to prevent fatigue in Ian's attempt to support himself. Further design requirements at this point could not be determined until an acceptable vehicle was identified.

Vehicle Selection

Several battery-powered electric vehicles designed for children are available at a reasonable cost. The Gaucho Grande Jeep was selected for use in the project and was donated by its manufacturer, Peg Perego through the efforts of Lisa Hickman-Lause, Director of Industrial Relations and Paula Jenkins-Williams, Director of Development and External Relations for the school. Additionally, EDS Corporation donated funding to support the cost of modifying the Jeep for Ian's use. The Gaucho Grande has a passenger weight limit of 250 pounds and uses two drive motors for propulsion. The heavier construction of this design allowed for the required additional weight of the seat and support structure along with space necessary for placement of the electronic circuits and the potential of using differential wheel speed to steer the Jeep.

Control System Modifications

The Gaucho Grande Jeep standard electrical controls schematic is shown in figure 1 of the appendix. Originally, the forward/reverse direction of the Jeep was selected by moving a floor-mounted lever to one reverse position or two forward positions. The first forward position placed the drive motors in series for the lower speed range. The second forward position placed the drive motors in parallel allowing higher speed. Power was applied to the motors by depressing a foot pedal. Releasing the foot pedal applied a load resistor across the motor to act as a braking device. In series with the battery and the circuit was a thermal bi-metallic switch that prevented continued operation at high current. A 40-ampere fuse protected the battery circuit. Steering was manually controlled by the rider in the form of a rack and pinion to the front wheels.

To accommodate Ian's physical limitations, a single joystick to control forward/reverse motion with left/right directional control was selected to replace the existing controls. Forward and reverse direction would be simply using the joystick to apply voltage or a signal to the motor. The Jeep's steering could incorporate differential drive to the motors or a completely separate circuit or steering control system. The use of a digital control circuit was preferred to limit the voltage and current levels in the joystick since fewer mechanical controls would result in a lower potential for failures. Original safety features would be left in place, specifically, the 40-ampere fuse and the thermal switch. The original foot switch and the forward/reverse floor lever were removed and initially replaced with relays that were controlled by the joystick and speed range was controlled by hard wiring the drive motors in parallel.

Steering Control System

It was decided to install a separate circuitry for the steering system into the Jeep rather than use motor differential control for steering. This would allow leaving the current steering mechanical hardware in the Jeep and allow the Jeep to perform as close to the original design as possible. The steering wheel was replaced with a bi-directional motor and a provision for control signals to display left and right movement of the joystick. A high torque motor was located to apply steering direction. The motor was mounted and connected directly to the steering wheel shaft. The left and right switches were wired to provide a constant ground to both sides of the motor while in neutral position movement to the left or right would remove the ground from one side of the motor and apply 12 VDC causing the motor to rotate and steer the wheels in the corresponding direction. Limit switches would prevent the motor from running the pinion gear beyond the ends of the rack. The steering would stay at that position until moving the joystick in the opposite direction would return the steering toward neutral. Appendix, figure 3 shows the steering control system schematic.

Drive Control System

Initially, relays were installed to allow for testing of the joystick controls and the ability of Ian to occupy and operate the vehicle. The circuit would allow for testing the demand of the two motors during operation and the potential of additional drain on the battery circuit caused by the addition of the steering motor. It was felt that acceptable performance could be achieved by allowing the motors to run as originally configured by the manufacturer, full-on/full-off. Therefore, no electronic speed control was added to the motor control circuit. The initial design simply called for a switching circuit that would apply voltage or ground to either side of the motor as needed for direction. A solid-state switch that could handle the maximum current was selected.

Four Darlington high current transistors were the identified that could handle more than 40 amps. As shown in the schematic in figure 2 of the appendix, the transistors are arranged in an H-bridge format. The base voltage is taken directly off the collector of the transistor providing the voltage to its respective side of the motor. This allows for thermal and current control of the transistor. If current draw increases, the voltage drop across the limit resistor (L_{limit}) will cause the base voltage to lower and eventually shut off the transistor. The on state of the opposite side of the motor at present is controlled by the normally closed contacts of the joystick. With the joystick in neutral it provides biasing to apply ground to both sides of the motor is voltage is produced in the motor, therefore, acting as a dynamic brake resisting any rotation of the motor. As the joystick moves in either direction, the NC contact is opened and only the appropriated transistor will apply ground to the motor.

The initial design was to allow self-biasing of the transistor providing the ground. However, with the low voltage drop across the motor that would be present when the motor was not turning, the possibility existed that both transistors could turn on resulting in both 12 volts and ground to be applied to the same side of the motor. This condition would cause extensive testing of the current protection in the design. A current limiting resistor provides circuit current protection. The value of the limiting resistor was calculated at a full voltage drop of 12 volts to ground and limiting current to 40 amps with sufficient time to allow recovery or activation of the factory safety

devices. This condition would cause the Darlington transistors to shut down due to lack of biasing voltage.

Some design considerations for the circuit, would be to have small signal transistors handle the switching of the Darlington transistors. This would allow all four transistors to be controlled by the solid-state switch and allow the joystick to provide the signal instead of the actual voltage to the circuit. A pulse-modulated circuit with a potentiometer joystick was used to provide speed control to the motor rather than a full-on/full-off design. MOSFETs were used to control the motor and reduce the voltage loss through the switches. The Darlington's require a 1.2 to 1.4 volt base to emitter voltage to conduct with the possibility of a 3.5-volt loss at 50 amps and 2.5 volts at 25 amps. MOSFETs routinely are used in H-bridge circuits and initial research showed a problem locating N channel MOSFETs to handle currents in this range.

Seat Design

The modified Gaucho Grande Jeep required the addition of a seat to support Ian. Given that the intended use of the Jeep would include outdoor operation over uneven ground and given the nature of Ian's physical size and body weight distribution, seat design was very important. These design factors resulted in several seat designs being investigated. The critical design aspect was the requirement for substantial support in the head region. As previously mentioned, approximately 40% of Ian's body weight was above his shoulder area. Initial designs included custom molded seats using carbon fiber or plastic. Upon further discussions with Dr. Dietzen, it was identified that Ian would continue to change physically due to growth and changes in his condition. In order to extend the useful life of the Jeep, it was decided to employ an adjustable seat with head support. The decision was then made to adapt a youth wheel chair design with adjustable side bolsters and head support for use in the Jeep. With the seat design determined, calculations were completed to determine the center of gravity of the Jeep with Ian in the seat to insure stability for outdoor use. CG calculations were a major factor in limiting the Jeep's speed through the electronic controls. A final concern was the secure mounting of the seat to the plastic molded structure that comprises the body of the Jeep. A relatively complex, sandwich-type mounting bracket was designed and fabricated to provide sufficient strength for the seat.

Additional mechanical modifications consisted primarily of the design and fabrication of brackets for the joystick and steering motor. When told of the nature of the project, several Indianapolis area fabrication companies donated the material and labor necessary for the mechanical components on Ian's Jeep.

Results

Before attempting to drive the modified Jeep, Ian spent time with an occupational therapist learning to operate the joystick. Ian readily adapted to the Jeep's modified controls. Within a few minutes of the formal presentation of the Jeep to Ian, he had full mobility. The picture³ shows Ian Farrar, Dr. Dietzen and the IUPUI Jaguar Electric Jeep. Because of the publicity the project received in the local news media, Indianapolis Racing League (IRL) driver Scott Goodyear sent autographed pictures to Ian and the two engineering technology students who did the conversion. Scott Goodyear then invited Ian, his father and grandmother to be his guests during practice for the Indianapolis 500 race in May 2001 and personally met with the family.

Significant was two quotes from an article in the December 8, 2001 edition of the Indianapolis Star⁴:

“I got a chance to meet Ian two or three times,” says the 31-year old Blackwell, who graduated in May with a degree in mechanical engineering technology and now works for Ford Motor Co. “Meeting him was the joy of it,” Blackwell says, “He’s got a lot of energy. He’s had a lot of effect on me, too. It makes you realize how fortunate you are. It also makes you realize how fortunate you are to be in a position to help someone.”

“This was just a way where we could help give Ian a different means of getting around,” says Venne, a 44-year old father of four who also has a full-time job and serves as a part-time firefighter for the Greenwood Fire Department while pursuing his degree in electrical engineering technology. “It was a worthwhile project,” Venne says. “It’s not a project to get a grade. It’s a project that affects someone’s life.”



Ongoing Projects

The partnership between the School of Engineering and Technology and the Timmy Foundation is ongoing and includes other senior design projects. For example, Electrical and Mechanical Engineering students designed and fabricated a device incorporating a vibrating sensor to help a young boy with no feeling in his legs be able to sense when his feet are touching the floor. Another Mechanical Engineering student project involves the development of a mechanical device to hold the eyelids of premature babies open to allow examination. A third example is and Mechanical Engineering Technology student’s project involving the design of a tracheotomy tube for babies that will allow a higher degree of motion

On a much larger scale, a \$3 million dollar Gossamer Spirit project is being launched which explores the use of advanced engineering design to allow athletes with paralysis to achieve the dream of human-powered flight using upper body power alone. This large project is the fusion of high technology with education to help others achieve their dreams and is the vision of Dr. Chuck Dietzen of the Timmy Foundation.

Through a collaborative effort, Indiana will be home to the Gossamer Spirit Flight and Education Center, which will include both a hanger facility where the Gossamer Spirit aircraft is to be built and also a state-of-the-art, interactive educational center. Children will be able to visit the Center and participate in hands-on experiments that demonstrate the concepts of flight, science and technology. Children from throughout the world will also be able to participate in the project by way of fiber optic connection to the Center. A key to the project is teaching the social impact of technology while allowing children of various capabilities to participate.

The School is the lead academic institution with faculty and staff playing a large role in the planning and implementation of the project. Engineering and engineering technology students will be involved in the project as it unfolds. A notable partner is Dr. Paul MacCready, who is internationally recognized as the "father of human-powered flight". Among his countless achievements is the Gossamer Condor, which in 1977, was the first sustained, controlled flight made by a heavier-than-air craft powered solely by its pilot's muscles. Two years later, he designed and built the Gossamer Albatross, a 70-pound craft with a 96-foot wingspan that achieved a human-powered flight across the English Channel. The Gossamer Condor is on permanent display at the Smithsonian's National Air and Space Museum in Washington, D.C., adjacent to the Wright Brothers' 1903 airplane and Lindbergh's Spirit of St. Louis.

Through the generous contributions of Paul Estridge Jr., head of the Estridge Companies, and Matt Hagans of Eagle Creek Aviation Services, the Gossamer Spirit Flight and Education Center will be built on land located at the Eagle Creek Airpark. Other partners include Schneider Corporation that donated the architectural and engineering designs for the facility. The first flight of the Gossamer Spirit will take place in 2003, the year of the 100th anniversary of the first flight at Kitty Hawk, North Carolina.

Conclusions

The vision of the partnership between Dr. Dietzen and the School of Engineering and Technology is to harness the technical talent of the engineering and engineering technology students to help people in need and to remove boundaries for people with physical limitations. The health care system does not always respond to the specific needs of individuals and if they do, the price tag is typically far too large for families to afford. Partnerships like this one are important for reaching out to the community around any school or institution. The Ian Jeep project changed a little boy's life and made a tremendous impact on the two senior engineering technology students as well as the faculty and staff of the school. The IUPUI Jaguar Jeep project also clearly demonstrated the benefits of this type of partnership and has laid the foundation for a positive and mutually beneficial relationship.

Bibliography

1. The Design and Implementation of Electronic Controls on a Jeep for a Child with Physical Disabilities. Senior Design Report. Mike Venne. Purdue School of Engineering and Technology. Unpublished. December 2000.
2. Mechanical Modifications to Child's Jeep for Handicapped Use. Senior Design Report. Scott Blackwell. Purdue School of Engineering and Technology. Unpublished. May 2000.
3. Photo Credit: Gary Moore. Indianapolis Star. December 8, 2000.
4. Indianapolis Star, December 8, 2000. Section E, p 1-2.

Biographies

KENNETH RENNELS, P.E.

Chair, Department of Mechanical Engineering Technology, Associate Professor Manufacturing Technology IUPUI.

MARVIN NEEDLER, Ph.D.

Chair, Department of Electrical Engineering Technology, Professor Electrical Engineering Technology IUPUI.

CHUCK DIETZEN, M.D.

President Timmy Foundation.

PATRICIA FOX

Assistant Dean, Financial Affairs, Purdue School of Engineering and Technology IUPUI.

SCOTT BLACKWELL

Bachelor of Science in Mechanical Engineering Technology, May 2000, IUPUI.

MICHAEL VENNE

Electrical Engineering Technology, Senior, IUPUI.

LISA HICKMAN-LAUSE

Director for Industrial Relations, Purdue School of Engineering and Technology IUPUI.

PAULA JENKINS-WILLIAMS

Director for Development, Purdue School of Engineering and Technology IUPUI.

ELAINE COONEY

Associate Professor Electrical Engineering Technology.

ROBERT HERMAN, P.E.

Visiting Lecturer Mechanical Engineering Technology.

APPENDIX

Figure 1 – Original Drive Schematic

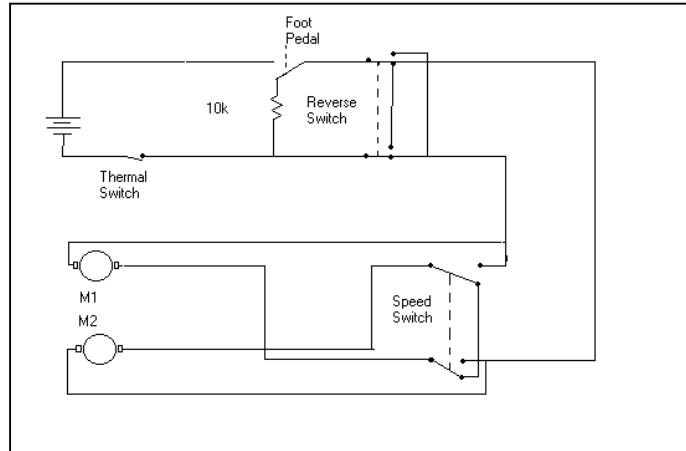

Figure 2 – Motor Control Schematic

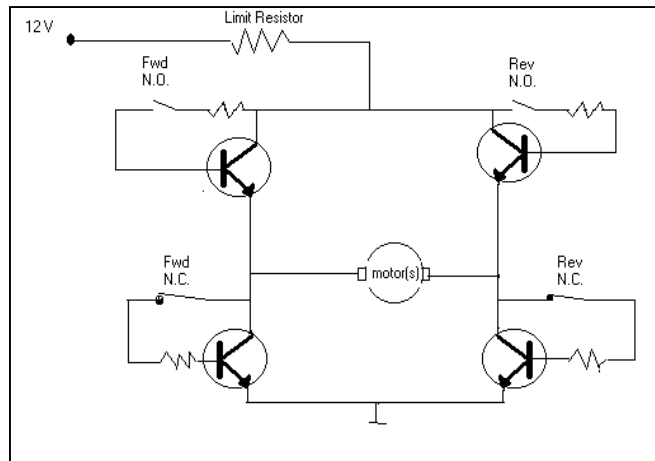

Figure 3 – Steering Schematic

