

Graywater Flow: Generating Sustainable Energy

Prof. Bala Maheswaran, Northeastern University

Bala Maheswaran, PhD Northeastern University 367 Snell Engineering Center Boston, MA 02115

Sophie Ray

Matthew Rock

Dilyn McHugh

Kyle Potts

David Ian Hunter

Graywater Flow: Generating Sustainable Energy

Bala Maheswaran, Matthew Rock, Dilyn McHugh, Sophie Ray, Kyle Potts,
and David Hunter
College of Engineering
Northeastern University

Abstract

The climate doomsday clock is counting down rapidly, and we must quickly find solutions to generate green energy and reduce our reliance on fossil fuels. The average American uses a lot of water each day. If we could harness all of the excess water for energy, we would be able to produce sustainable electricity from what would otherwise be wasted. A majority of energy that humans use is produced by natural gas, nuclear power plants, and coal, which damages the environment. Coal and gas are not sustainable resources and will eventually run out. They also produce greenhouse gasses and destroy the Earth through mining for gas and coal. Contrary to this, hydroelectric power does not hurt the environment as the kinetic energy from wasted water can be used to generate electricity. This also does not create any further waste unlike the greenhouse gasses produced from burning coal and oil.

We have designed a device with the goal of turning everyday runoff water into energy. Our problem was to find a way to conserve energy in order to advance towards a more environmentally friendly world. We observed that there was a lot of runoff water from many different sources during the day, so we decided to construct a water wheel that would be able to be placed under runoff water sources in order to harvest this excess water to use towards energy. Our water wheel aims to provide all with a means to generate power from waste water in their homes. When addressing the problem we made sure to account for socioeconomic factors as well, as a focal point of our design was availability and convenience. Thus, we arrived at a prototype that is 1) cheap and easy to build, 2) relatively small and easy to install, 3) interchangeable with most plumbing systems in bathrooms and kitchens, resizability would also account for this, 4) environmentally conscious materials. Our device is a water wheel that can be fitted onto many different types of pipes, and produces a small amount of energy. We believe that with many of these within a building we would be able to generate a reasonable amount of energy for utilization for any purpose.

Introduction

Today, people are using electricity more than ever, and as climate change is increasingly creeping up on us, finding new sustainable sources of energy has become vital. The average person wastes about 30 gallons of water daily [1]. There are two solutions to this problem: repress how much water is used or recycle this wasted water into energy. Recycling the energy of used and wasted graywater, falling down a drain into usable energy would help solve the growing need for sustainable energy. Hydropower is one of the oldest forms of renewable energy, but it only accounts for about seven percent of total electricity generation in the United States [2]. The overarching goal of this project is to make hydropower available to all at a reasonable price. The production of this product is in pursuit of a widely used device that can help reduce our reliance on fossil fuels and as a result slow climate change.

Our waterwheel allows the production of energy by combining the gravitational force of the water and the kinetic energy of the wheel. Some constraints in the design of this device include cost efficiency, scalability, and overall size. The audience we are trying to reach with our product is average households and institutions. Although an individual device does not generate enormous energy on its own, planting multiple devices in at least one building will accumulate a powerful amount of energy. Take our University as an example; consider how many students live in a particular housing building and how many times per day the bathroom sink is run. If each sink had our waterwheel planted in the drains, the gray water runoff can generate a lot of energy over the course of a semester. That is the goal of Graywater Flow.

Method and Approach

The following image is a 2D sketch of our initial design plan.

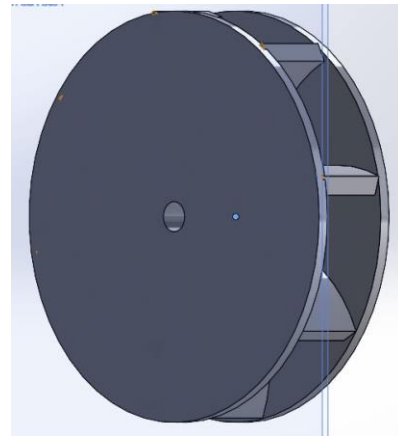
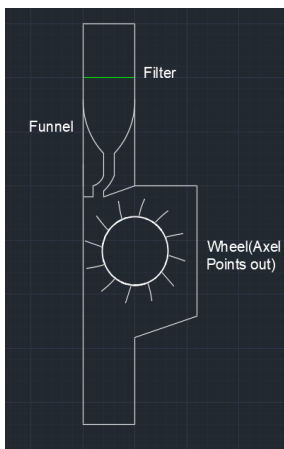

Figure 1a: Initial 2D design Figure 1b: Initial 3D Wheel design Figure 1c: Wheel digital

Our initial design {Figures 1a, 1b, and 1c} utilized a few components that we determined necessary to make our product as effective as possible. Each of these components was designed towards addressing a particular goal or obstacle. Firstly, we determined that we would need a part that allowed us to concentrate the inflow of water. One of our design goals was to make our project applicable in all sorts of drains, and fixtures like water fountains and sinks tend to drain less water than showers. Therefore, we developed a few ideas that would help us maximize the flow rate of water so that we had enough to make sure the wheel spun. Our first option was a siphon, a complex device that uses basic fluid physics principles to transport and concentrate the flow of water. Our second option was simply a funnel that would collect water in a large basin and then direct it through a small tube pointed directly at our wheel. We decided to go with the funnel because it would be much easier to 3D print, and would make our design more simple and compact. In short, the funnel better aligned with our design goals of making our product universally scalable. We designed this piece in SolidWorks and 3D printed it with the following dimensions (adding a bowl to increase the basin size): Basin Diameter: 6 in, Tube Diameter: 1 in, Thickness: $\frac{1}{4}$ in

The next aspect of our design, and perhaps the most important piece, is the water wheel. We did extensive research on the different types of water wheels and various aspects of the design to

determine what build would be best suited for our product. The three types of water wheels we discovered were the overshot, undershot, and breastshot wheels. The only aspect that differed between these wheels was where the flow of water made contact with the wheel's blades. Our wheel most closely resembles the overshot wheel, as it is positioned so that the input of water makes contact with the wheel at the top of its rotation. We paired this technique with curved blades in an effort to make use of the water's potential energy. We see the force diagram, as the force on the wheel's blade by the weight of the water created the torque, causing it to spin.

Once we had determined the features of our wheel, we designed it in SolidWorks with eight blades. In addition to our wheel, we developed two flat discs that would be attached on either side of the wheel. The purpose of these discs was to maximize the water's potential energy by keeping the water in the blades as opposed to letting it splash out. In essence, these discs allowed us to manipulate the translation of potential energy to rotational kinetic energy to our advantage. In our first prototype, we laser cut these discs from acrylic and glued them on, but after some issues with our initial design, we decided to reprint the entire part which included both the discs and the wheel connected to each other. This part also had a hole in the center for a dowel, which we would use to attach our product to a generator. Our final wheel was printed with the following dimensions: Diameter: 5in, Thickness: $1\frac{1}{4}$ in, Disc thickness: $\frac{3}{8}$ in.

The second component of our wheel apparatus was a dowel that we would then attach to a Sparkfun motor to measure our power output. We acquired a $\frac{3}{8}$ in dowel from FYELIC that we glued to the interior hold on our first wheel. We encountered an issue with this aspect of our design, as the dowel was slightly crooked due to a miscalculation when designing the hole in the wheel. When we reprinted our wheel, we did so with a $\frac{3}{8}$ in hole that perfectly housed our dowel. We then glued this piece into place to ensure that it was as secure as possible. Aside from our wheel and dowel, we needed to develop housing that would take up as little space as possible while still maintaining structural integrity by holding the parts in place and keeping all water inside. In our first prototype, we simply had the dowel fit into $\frac{1}{2}$ in diameter holes in the housing. However, we soon realized that this caused a lot of friction between the working parts of our product, causing the wheel to be stuck often. When we reprinted our wheel apparatus, we also redid our housing and purchased bearings with the following dimensions: Inner Diameter: $\frac{3}{8}$ in Outer Diameter: $\frac{5}{8}$ in

After laser cutting our new housing, we simply popped these bearings into holes of the appropriate size and reinforced the bond with glue. The bearings made a big difference and significantly reduced the amount of friction between the dowel and the housing, allowing the wheel to spin more smoothly and produce more power.

One of the more important goals in our design was scalability as we sought to make this product available to all and interchangeable with all plumbing systems. We determined that scaling this design was as simple as making a few minor adjustments to the SolidWorks designs, and thus reinforced our goal of making our design universal. This goal goes hand in hand with our future vision for the product, as it would be most effective if applied to every drain in a building.

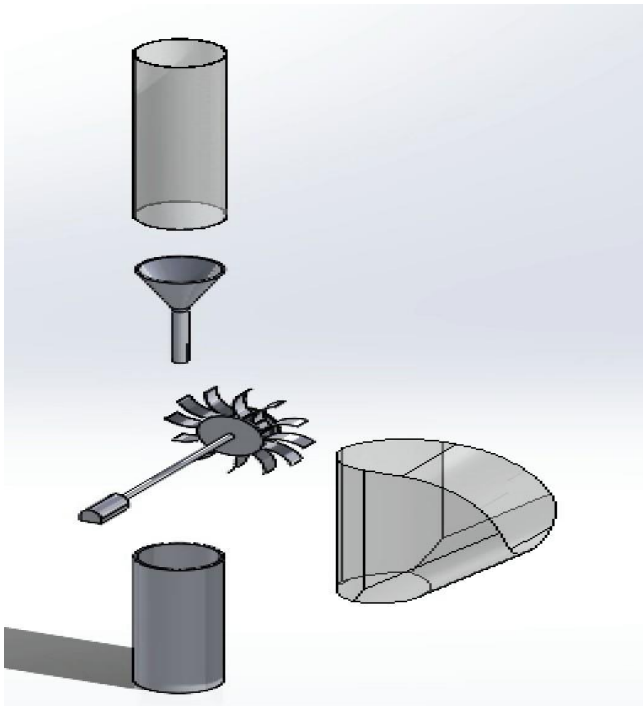

Figure 2a: Solidworks exploded model

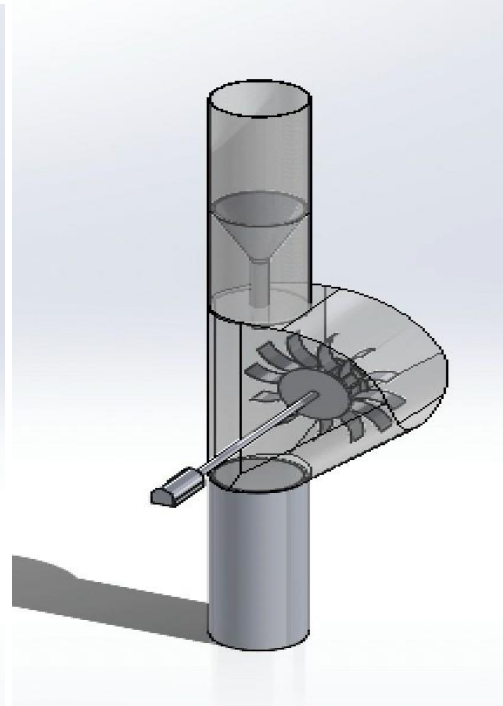

Figure bb: Solidworks model



Figure 2c: Front view of the final product

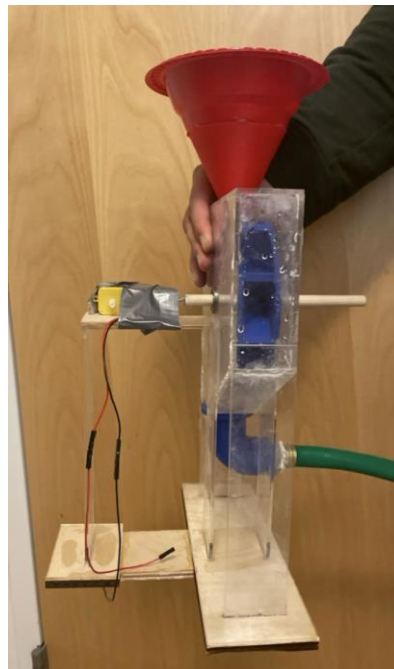

Figure 2d: Side view of the final product

Results and Analysis

As stated previously, we had an initial iteration of the wheel that we chose to not use in our final model. We decided that this wheel was ineffective due to the previously mentioned friction, so we did not test this wheel with the voltmeter, as we would need to build supports for the Sparkfun generator, which would have been a waste of time due to already ruling the wheel out

Once we had assembled the second wheel and housing, it was spinning at levels that seemed adequate to us, so we glued in the Sparkfun motor and waited for it to dry to conduct further testing. Initially, the Sparkfun motor read an increase of roughly 0.1 Volts when water was poured into the system. Unfortunately, at some point, we believe due to water entering the bearings and causing them to lock, the wheel became less efficient. Readings after this issue have ranged around .05 Volts while the wheel is spinning.

Our results are quite low for these tests, but we believe that if a better generator were used, it would allow us to gather much better results, as even when spinning by hand as fast as possible, only up to around 1.5 Volts are produced by the Sparkfun motor. In addition, it should be noted that placing multiple systems in a building would allow small results to add up over a large number of systems.

The following two images [Figures 3a and 3b], are graphical representations of the data gained from two tests that were run after the bearing issue began, both of which display that the wheel was able to produce around .05 Volts while spinning

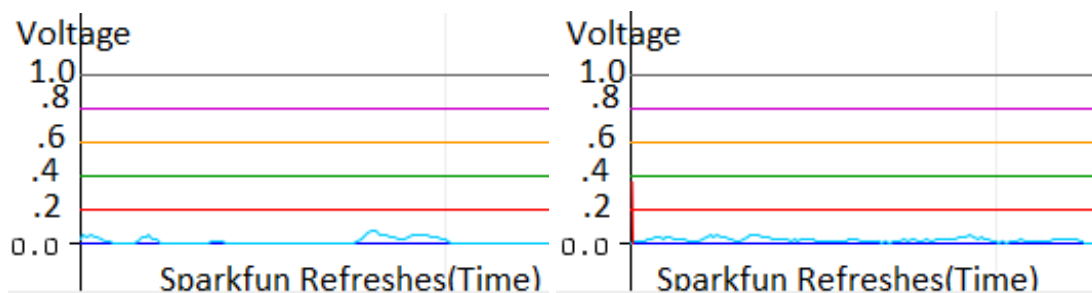

Figure 3a: Water pour data #1

Figure 3b: Water pour data #2

Appendix 2 shows the raw data readout of the Sparkfun generator while water was being poured into the top of the system during a third test, further showing that the system produces roughly 0.05 Volts while water is going through the wheel. Therefore, our system as it currently is able to produce 0.05 Volts, which has the potential to improve in a future design by using a better motor, and a system that is designed more towards usability instead of presentability, and is not based around the Sparkfun generator to the same extent as our design is.

Our device was able to generate .05 Volts, and Sparkfun motors have a maximum amperage .25mA or .00025 Amps [3]. From here, we are able to use the equation: $1\text{ Volt} \times 1\text{ Amp} = 1\text{ Watt}$, so our device specifically generates $.05 \times .00025 = 1.25 \times 10^{-5}$ Watts. This is also equivalent to 1.25×10^{-8} Kilowatts.

With that in mind, we need to see how many hours per day; Americans are using faucets in order to determine our kilowatt-hours per day. First, the average American uses 82 gallons of water per day at home alone, so we will use this number to calculate [4]. Secondly, faucets in the United States operate at a standard flow rate of 2.2 gallons per minutes, or 132 gallons per hour [5]. Thirdly, there currently roughly 333,500,000, or 3.335×10^8 Americans [6]. With these three numbers, we are able to calculate the time that water is used by multiplying

$$\text{Americans} \times (\text{Gallons/Flow Rate}) = \text{Hours of usage}$$

Therefore, this will give us

$$3.335 \times 10^8 \times (82/132) = 2.07 \times 10^8 \text{ Hours of water usage per day in America.}$$

Now that we have our Kilowattage and our hours of water usage per day, we can determine our Kilowatt-hours if our system specifically was placed in every American home's water output by multiplying them together. This gives us

$$2.07 \times 10^8 \times 1.25 \times 10^{-8} = 2.59 \text{ kWh per day in the United States}$$

If we were to use our system before the bearing issue, this would double to 5.18 kWh/day

This number is not ideal, as producing one wheel for every single drain system in the United States is a tremendous goal, but it still provides proof of concept for an ideal version of our system. Ideally, we would be able to produce much more voltage at a higher amperage with some adjustments to our wheel. Previous studies have found that small water wheels are able to produce 3.5 volts directly next to a faucet, with 2.0 amps of current [7]. Since our design utilize runoff water instead of water directly from the faucet, we would most likely get a lower voltage than 3.5, as we would only have gravity to work with.

If our design were able to produce one Volt at two amps, Using our previous calculations, this would be $1V \times 2\text{Amps} = 2\text{Watts} = .002 \text{ kW}$, which with the previous hours of water usage would be $2.07 \times 10^8 \times 2 \times 10^{-3} = 4.14 \times 10^5$ or 414,000 kWh per day in the United States.

Conclusion

The goal of our project was to produce electricity from the kinetic energy of wastewater and for our project to be scalable and cost efficient. We reached our goals by creating a 3D printed water wheel in a laser cut acrylic housing with a funnel directing water onto the wheel. Our design minimized the cost of our project and allowed it to be scalable because it was 3D printed.

Although the energy we produce is not enough to charge a phone, power a TV, or do anything productive, since we are using kinetic energy from wasted water, any electricity that we generate is profitable. With many devices implemented in a building on all the plumbing and drain systems, we could potentially produce ample energy that can be used. The scalability of our project also contributes to its effectiveness as bigger versions could potentially be used in things such as street drains and smaller versions could be used in things such as gutters on buildings. Our idea is not the first of its kind and in fact, there have been many concepts similar. We decided to create our own original design to innovate further on this idea. This is why we included a funnel into our design. Our funnel directs water flow directly onto our wheel's blades, which greatly improves

efficiency without creating too much backpressure on the drain system. This means that we are able to generate more power and still have the water drain quickly. Our team's hard work and cooperation allowed us to reach our goals of creating a cost efficient and scalable product able to generate electricity from wasted water. We were able to create an innovative and original design for a water wheel capable of reclaiming energy from what would otherwise be waste.

References

- [1] "Stop Water Waste: It's easier than you think!"
<https://doh.wa.gov/sites/default/files/legacy/Documents/Pubs/331-450.pdf>
- [2] "Hydropower Basics," *Energy.gov*. <https://www.energy.gov/eere/water/hydropower-basics> (Accessed Apr. 28, 2022).
- [3] <https://cdn.sparkfun.com/datasheets/Robotics/DG01D.jpg> (accessed Apr. 28, 2022).
- [4] <https://www.epa.gov/watersense/statistics-and-factsn.com/datasheets/Robotics/DG01D.jpg>
- [5] "Bathroom Faucets," *US EPA*, Oct. 20, 2016.
<https://www.epa.gov/watersense/bathroom-faucets> (accessed Apr. 28, 2022).
- [6] "Population Clock." <https://www.census.gov/popclock/> (accessed Apr. 28, 2022).
- [7] Maheswaran, B., & Guo, Y., & Hervella, A., & Pavlov, A., & Dinh, M. D. (2019, June), *Water Flow Generator: Innovating Water Faucet Use* Paper presented at 2019 ASEE Annual Conference & Exposition, Tampa, Florida. 10.18260/1-2--33545

Appendix1: Data Collection using Arduino Software in a Sparkfun Redboard

```
#include <LiquidCrystal.h>
// Constants
int VOLTAGE_PIN = A0;
int Acontrol_variable = 5; int Bcontrol_variable = 3;
// Global variables
LiquidCrystal lcd(12, 11, 5, 4, 3, 2);

void setup() {
  // Initialize the annoying LCD and clear it
  lcd.begin(16, 2);
  lcd.clear();
  // Initialize the serial monitor
  Serial.begin(9600);
}

void loop() {

  int sensorValue; float voltage;
  // Read the analog value from A0
  sensorValue = analogRead(VOLTAGE_PIN);
  // Convert the analog value to a voltage
  voltage = ((float)sensorValue * 5.0) / 1023;
  // Display the voltage on the LCD lcd.setCursor(0, 0); lcd.print
  lcd.print(" V");
  // Wait 200 ms before taking another reading
  delay(200);
  // Serial controls Serial.print("Voltage:"); Serial.print(voltage);
  Serial.print("1 Volt:"); Serial.println(Acontrol_variable);
}
```

Appendix 2: Water pour raw data

16:20:10.040	->	0.01
16:20:10.549	->	0.01
16:20:11.056	->	0.01
16:20:11.564	->	0.03
16:20:12.025	->	0.05
16:20:12.534	->	0.01
16:20:13.043	->	0.04
16:20:13.553	->	0.05
16:20:14.059	->	0.05
16:20:14.567	->	0.04
16:20:15.076	->	0.04
16:20:15.585	->	0.07
16:20:16.088	->	0.05
16:20:16.551	->	0.03
16:20:17.054	->	0.06
16:20:17.566	->	0.05
16:20:18.078	->	0.05
16:20:18.594	->	0.06
16:20:19.062	->	0.08
16:20:19.578	->	0.07
16:20:20.093	->	0.05
16:20:20.609	->	0.03
16:20:21.078	->	0.04
16:20:21.594	->	0.07
16:20:22.110	->	0.08
16:20:22.579	->	0.06
16:20:23.095	->	0.06
16:20:23.611	->	0.04
16:20:24.081	->	0.06
16:20:24.608	->	0.08
16:20:25.124	->	0.03
16:20:25.592	->	0.01