

**Hand-Held Wireless Remote Control Thermostat System**  
**L. D. Allen and M. Tahernezehadi**  
**Department of EE**  
**Northern Illinois University**  
**DeKalb, IL 60115**

**ABSTRACT**

This paper provides the design of a hand-held wireless remote controlled thermostat system for the control of a residential Heating and Air-Conditioning (HVAC). Any person who can operate a telephone will be able to use the hand-held controller, which, for prototype purposes, will be fashioned from a telephone handset with push-button and sliding switch controls. With this remote control, a disabled person will be able to have complete HVAC control at their fingertips. The device will display ACTUAL TEMPERATURE with a green, 2-digit, 7-segment LED and SET TEMPERATURE with a red, 2-digit, 7-segment LED. The actual temperature and the setting temperature have a range from 00 to 99 °C.

**I. INTRODUCTION**

People with limited mobility require the same controls over their home's environment as people who have normal mobility. If the temperature setting in a person's home is too hot or too cold for comfort, the home's HVAC (heating/air conditioning system) control can be set to make the temperature more comfortable. For a person with normal mobility, this poses no particular problem as one can simply go to the HVAC control module and adjust the thermostat's temperature setting accordingly. However, for a person with a mobility issue, physically getting to the control module to adjust the setting could be difficult or impossible. Moreover, the wireless design project can be configured to turn on and off other household appliances, enabling individuals with limited mobility to remotely control multiple number of household appliances. The availability of the portable unit also provides the caretaker with a higher degree of effectiveness and flexibility, which in turn leads to a reduced healthcare cost for the patient.

**II. Design DISCRIPTION**

The device displays ACTUAL TEMPERATURE with a green, 2-digit, 7-segment LED and SET TEMPERATURE with a red, 2-digit, 7-segment LED. The actual temperature and the setting temperature have a range from 00 to 99 °C.

The device interfaces locally with the user via 3 push-button switches and 2 4-position slider switches with the following functions:

- |                 |   |
|-----------------|---|
| Push-button 1   | - Device Circuit/Microcontroller Reset                  |
| Push-button 2   | - Increment Temperature Setting                         |
| Push-button 3   | - Decrement Temperature Setting                         |
| Slider-switch 1 | - Function Selector Switch (Heater/OFF/FanON/Cooler)    |
| Slider-switch 2 | - Remote/Local ON/OFF Switch (RemoteON/OFF/OFF/LocalON) |

\* With LocalON control selected, all local switches are functional. Device status and switch settings are displayed via 6 LEDs and the aforementioned 7-segment LED displays. LocalON are clear green, RemoteON is clear red, Heater is red when the Heater is ON, OFF/Standby is amber, FanON is green, and Cooler is white green when the Cooler is ON.

\* The device determines actual temperature via interface with a DS1620 Digital Thermometer and Thermostat integrated circuit mounted on the exterior of the TCM casing. With Heater selected, the TCM will turn on the

heater when the actual temperature is below the set temperature and remain in OFF/Standby otherwise. With Cooler selected, the TCM will turn on the Cooler when the actual temperature is above the set temperature and remain in OFF/Standby otherwise. With FanON selected, the TCM will turn on the Fan regardless of temperature setting. With OFF/Standby selected, the TCM remains in OFF/Standby regardless of temperature setting. The device interfaces with the HVAC components via the Relay/Demo box which uses the microcontroller output to solid state relays to turn on the Heater, Fan, or Cooler. The device is powered by a Regulated 5VDC 500mA, 120V 60Hz AC adapter.

### III. The RELAY/DEMO Box

\* The device has three 240V, 25A solid state relays with 5V TTL control to switch on 3 standard 125V15A receptacles that power the Heater, Fan, and Cooler. Each relay employs a heatsink and an 8watt 120VAC internal fan that circulates cooling air into and out of the box. There will be a 125V15A power switch on the front of the box to energize the entire system. A fourth receptacle used to power the TCM AC adapter will be on whenever the power switch is on.

\* Total current at 125VAC 60Hz is specified not to exceed 15A as limited by the lowest rated internal components.

### IV. HARDWARE

The TCM was built as specified with the required switches, LEDs, DS1620 mounting, output plug (to Relay/Demo box), and power plug. The external casing of the TCM is diagrammed in Figure 1. The actual size of the casing is approximately 5"hx2.75"w x 2.25"d.

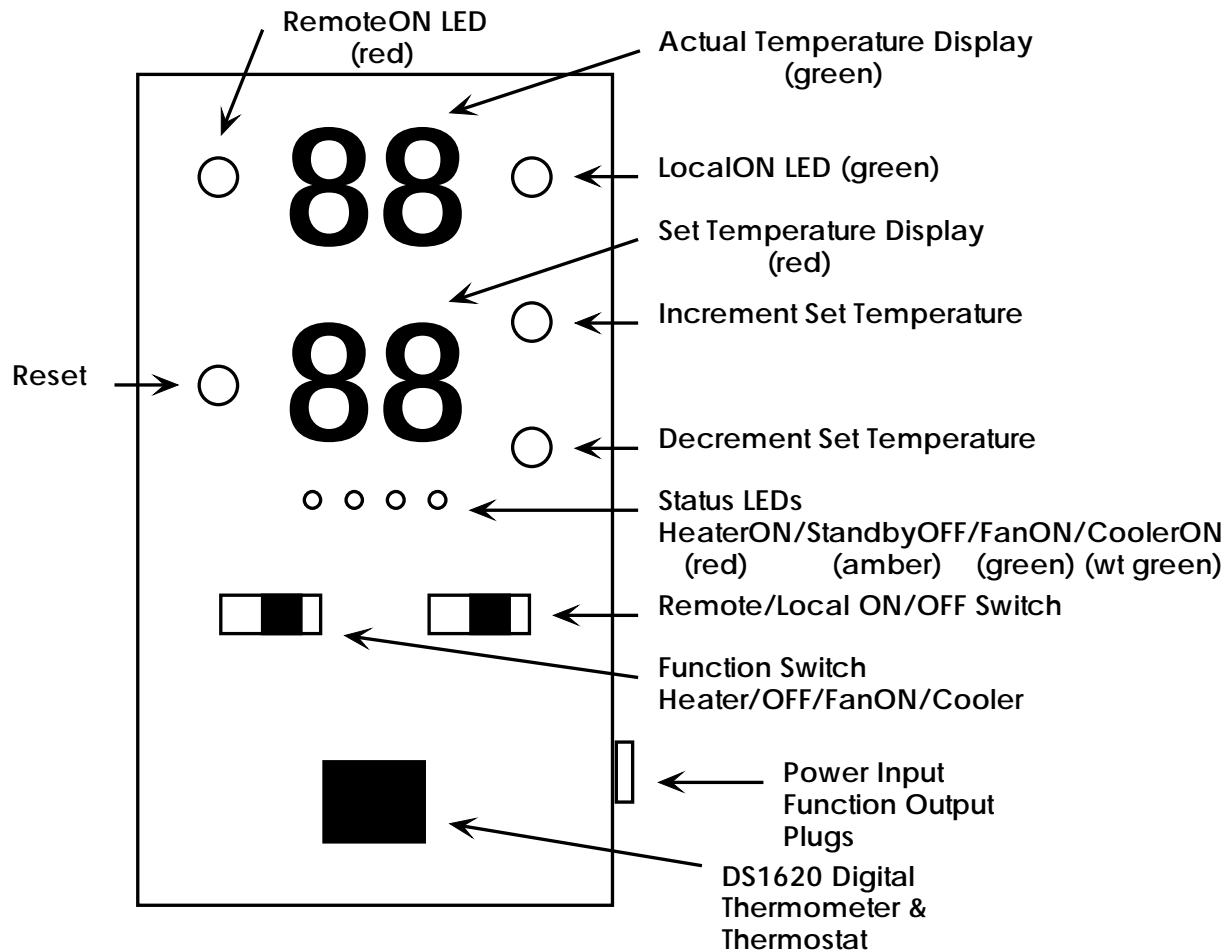

### **Figure 1 - The Thermostat Control Module (TCM)**

including switch, LED, and DS1620 protrusions. The TCM case has two holes drilled on the rear for mounting screws.

The microcontroller used to control all the processes of the TCM is the 8-bit Microchip PIC16C63/JW EPROM. The PIC (**P**eripheral **I**nterface **C**ontroller) 16C63/JW is a 28-pin DIP microcontroller with 22 I/O pins, 4K EPROM, and 192 bytes of RAM. The internal component connections are all based on the I/O pins of the PIC. The TCM PIC I/O pins and pin assignments are diagrammed on the following page in Figure 2. The pin functions are specified as follows:

- 1) Reset Button (Master Clear)
- 2/3) Function Switch Input - takes 2-bit logic input from the function selector switch
- 4/5) Function Selection Output - 2-bit logic output for function selection
- 6) Reserved for RF transmit/receive selection in Stage III development
- 7) Reset for DS1620 interface
- 8/19) Ground (0V)

# TCM PIC16C63 I/O PINS

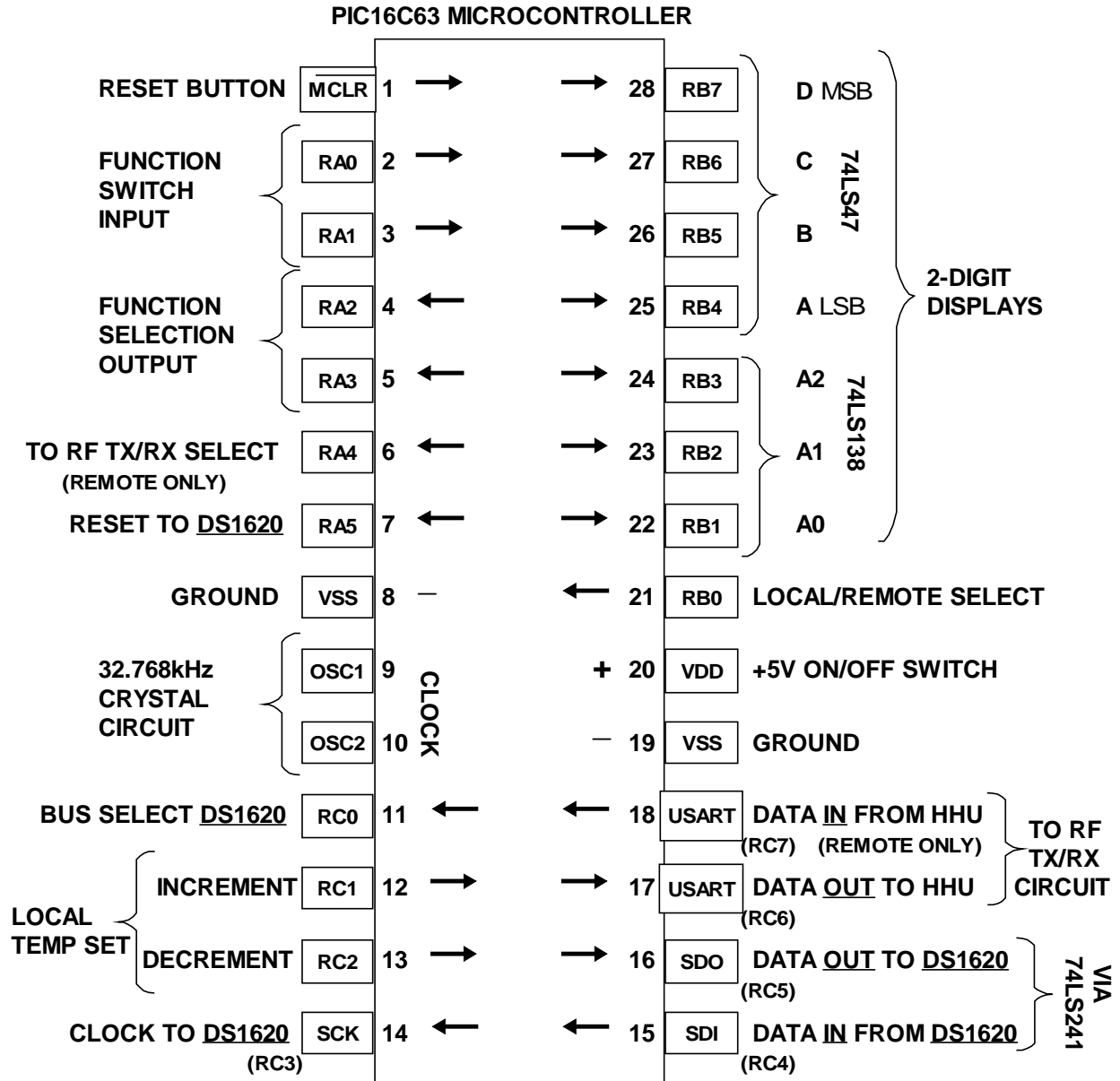
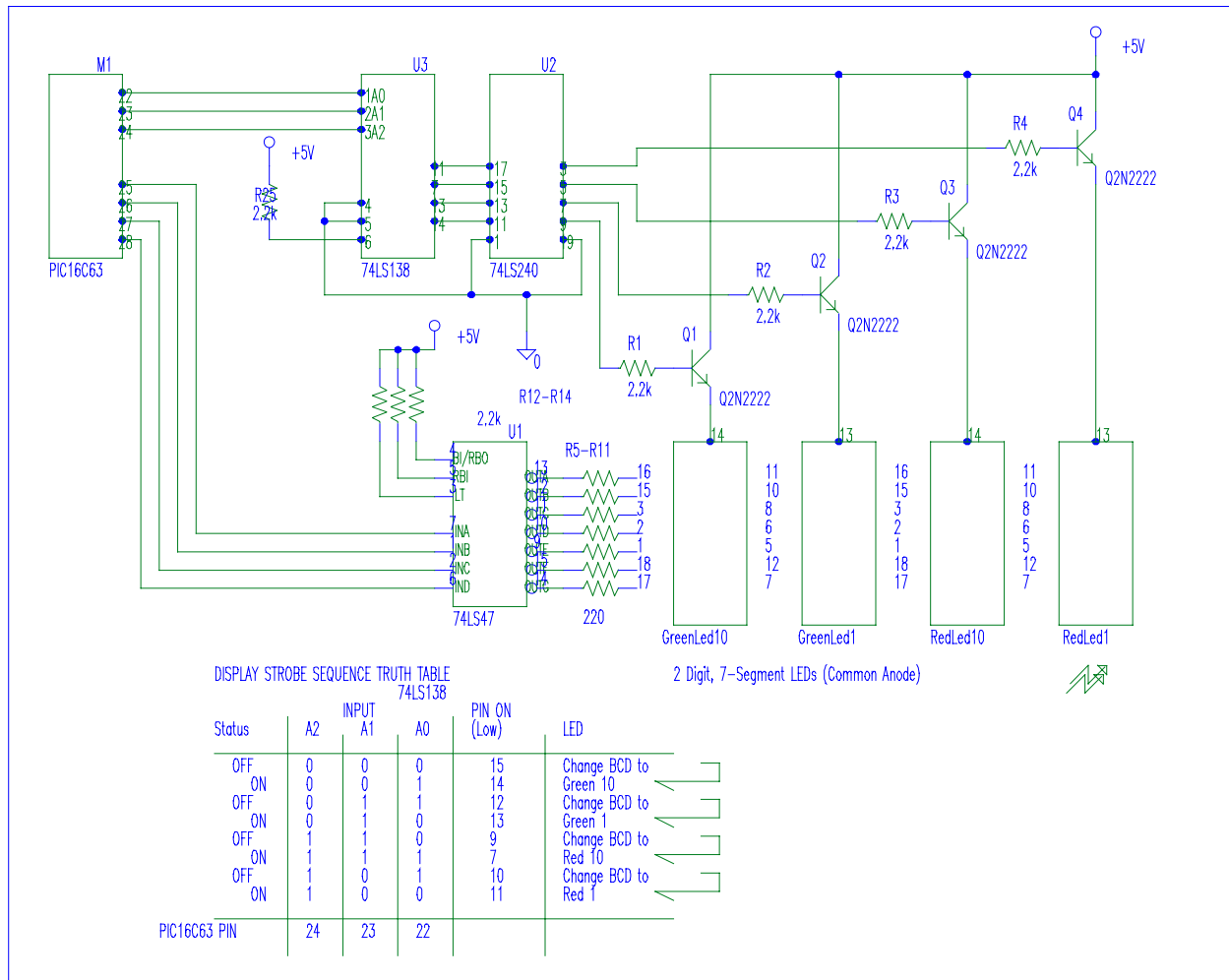

Figure 2 - The TCM PIC Pin Assignments

- 9/10) Exterior Crystal Clock Circuit (32.768 kHz Crystal - Low Power)
- 11) Bus selection bit for DS1620 communications
- 12/13) Increment/Decrement Switch Inputs
- 14) Output Clock for DS1620 interface

- 15/16) Data IN/OUT (SDI/SDO) for Serial Peripheral Interface with DS1620
- 17/18) Reserved for Data OUT/IN Communication with HHU in Stage II/III
- 20) +5VDC Power via Remote/Local ON/OFF Switch
- 21) Reserved for Local/Remote Selection from Remote/Local ON/OFF Switch
- 22-24) 7-Segment LED Strobing 3-bit Logic Selection (Output to 74LS138)
- 25-28) Binary Coded Decimal Output for 74LS47  $\Rightarrow$  7-Segment LEDs

The following three figures detail the schematics of the TCM. All connections were hand soldered and placed. During construction of the TCM, many changes were made to the originally planned layout, but the schematic remained true to the original design.



**Figure 3 - 7-Segment LED Display Circuit**

Figure 3 shows the 7-Segment LED Display circuitry. The theory behind this design is detailed in the Display Strobe Sequence Truth Table. Basically, the PIC controls selection (or non-selection) of the transistor switches to drive the common anode LED displays as well as the binary coded decimal required for the appropriate switch when on. Because the 74LS138 provide a LO (sink) output, the 74LS240 acts as an inverting driver to provide a positive voltage to the npn transistors.

Figure 4 shows the various subcircuits of the input switches, LEDs, and outputs to the Relay/Demo box. Note also that the truth tables are diagrammed for the various switch settings and output logic.

Section 1 is the Reset Switch (push-button grounds pin 1) with a  $68\Omega$  resistor between the switch and ground to prevent potential latch-up problems associated with excessive current. Section 2 are the Increment/Decrement Switches with the same basic circuitry as the Reset Switch. Section 3 is the Function Selector Switch with the appropriate pull-up resistors and ground for various logic combinations. Section 4 is the Local/Remote ON/OFF Switch with the appropriate configuration for its logic outputs to the PIC. Also included are the Local/Remote Indicator LEDs which are a function of the switch position. Note that both the Function Selector and the Local/Remote ON/OFF Switches are 4-position switches that change two poles at once. Section 5 details the Status LEDs and the output to the Relay/Demo box . Figure 5 shows PIC Clock/Temperature Support and Relay/Demo Box Circuit

## V. SOFTWARE

The PIC was programmed using the PIC Start Plus programmer and associated MPLAB IDE (Integrated Development Environment). Since the PIC instruction set only contains 35 instructions, learning the instructions was not difficult but programming at the bit and byte level of the assembly language and learning the architecture of an unfamiliar microcontrol was somewhat challenging. While the program successfully operates the TCM for the initialized ACTTEMP (actual temperature) there were several issues that could not be resolved within the time constraints of this stage of the project regarding interface with the DS1620.

The DS1620 uses a fairly simple 3-wire interface to communicate 9-bit temperature readings of the temperature of the device. The device must be initialized and controlled via this 3-wire interface. While the Reset and Clock pins of the device can be easily interfaced with the PIC, the DS1620 sends and receives data via the third wire of the interface. The PIC's SPI (Serial Peripheral Interface) protocol requires two separate data lines: One to send and one to receive.

The second issue involves the data transfer itself. The SPI interface protocol is limited to an 8-bit word data transfer with MSB first. The DS1620 sends 9-bit temperature reading, LSB first.

The final issue is that the Reset must be high from the beginning of a transfer to the end of the last (9th) bit when reading the temperature value. The DS1620's manufacturer web site "[www.dalsemi.com](http://www.dalsemi.com)" for Dallas Semiconductor contained an application note addressing these issues. The document is "Application Note 85 - Interfacing the DS1620 to the Motorola SPI Bus" by Michel St-Hilaire and Marc Desjardins of XyryX Technologies, Quebec City, Province of Quebec, Canada.

## VI. Conclusions

This paper presented the design of a wireless HVAC system. The design prototype is fashioned from a telephone handset with push-button and sliding switch controls as to allow disabled individuals who can operate a telephone to use the hand-held controller. With this remote control, a disabled person will be able to have complete HVAC control at their fingertips. The wireless design project can easily be configured to turn on and off other household appliances, enabling individuals with limited mobility to remotely control multiple number of household appliances. The availability of the portable unit also provides the caretaker with a higher degree of effectiveness and flexibility, which in turn leads to a reduced healthcare cost for the patient.

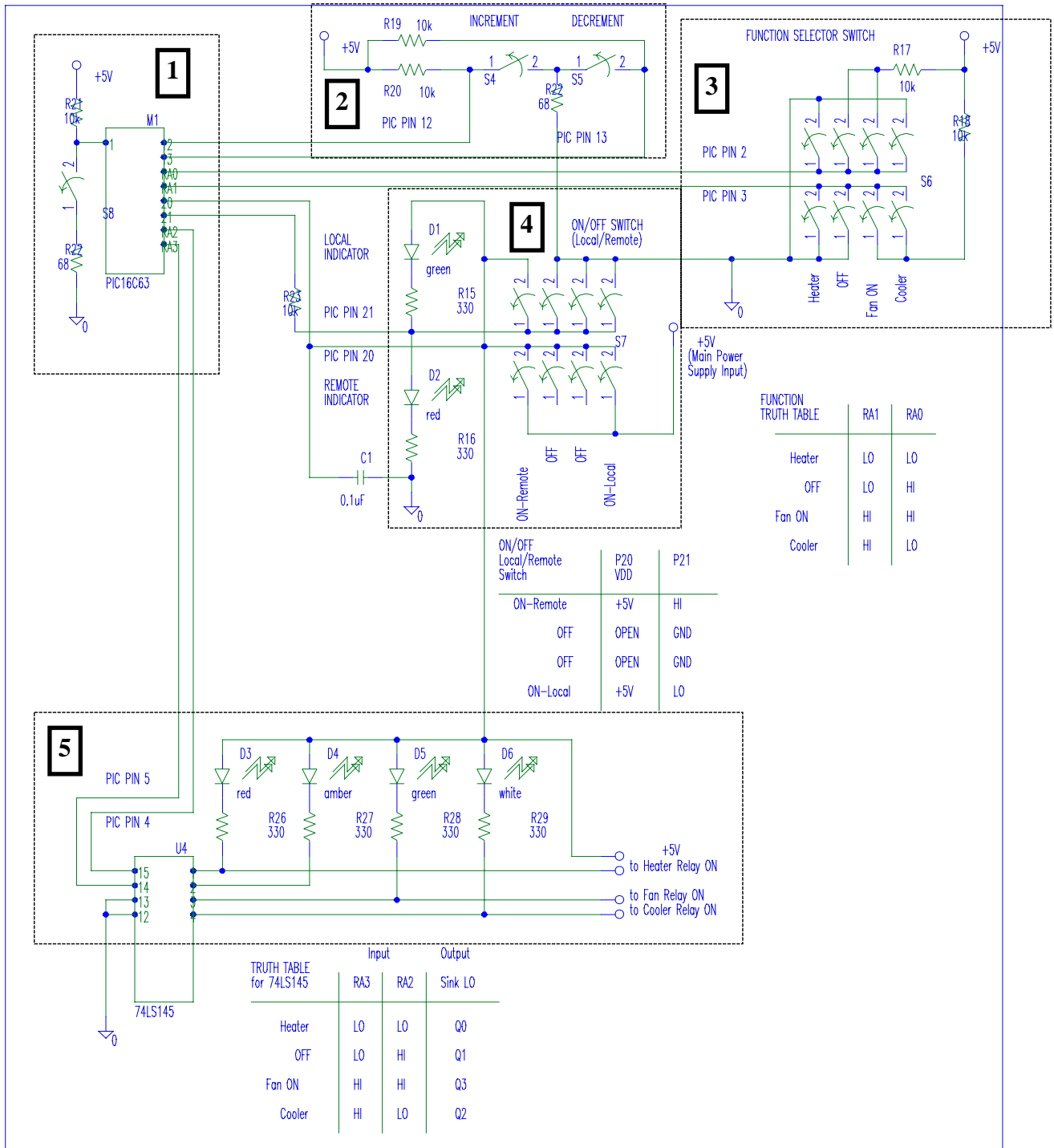
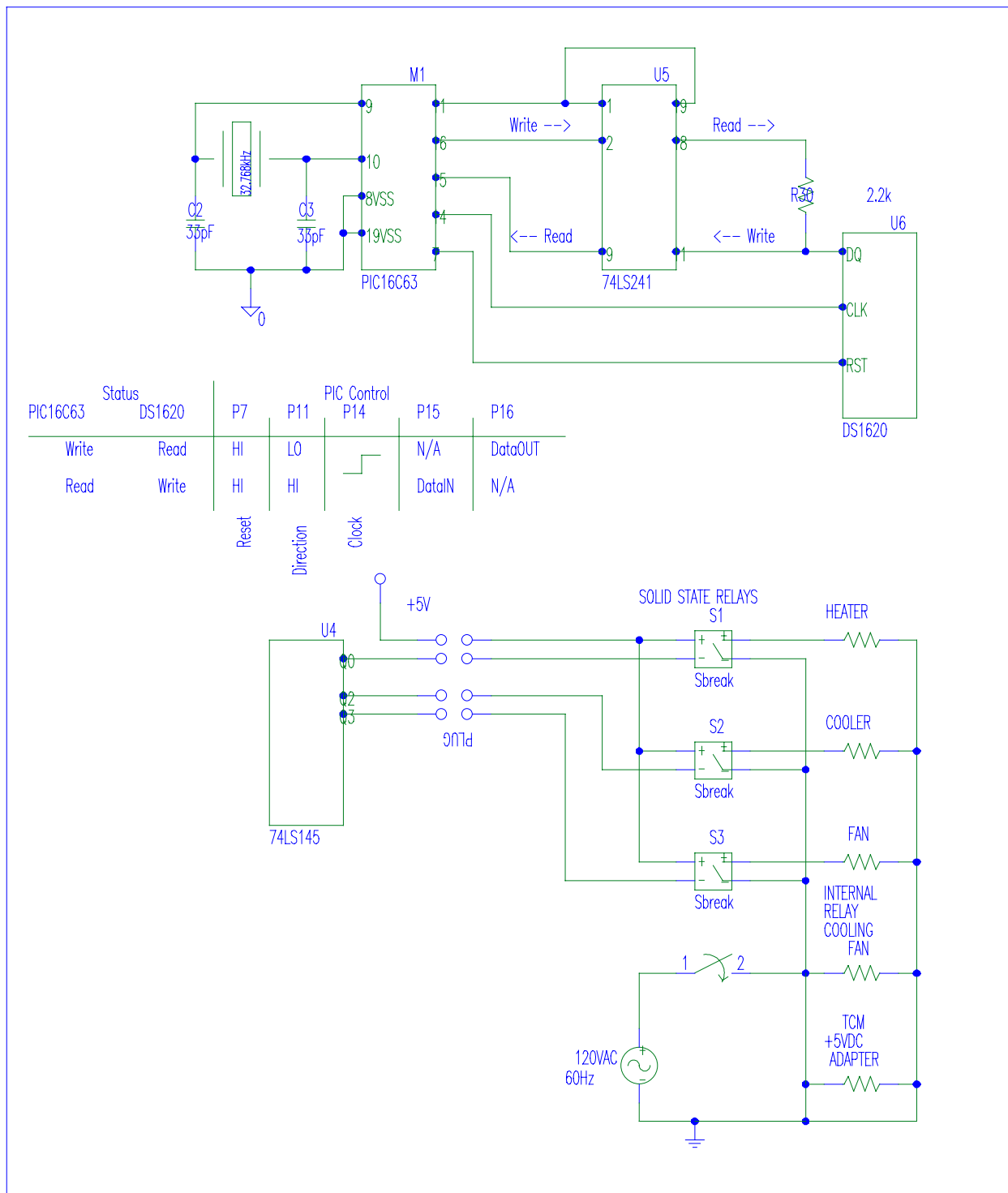

Figure 4 - TCM Input Switches, LEDs, and Output to Relay/Demo Box



**Figure 5 - PIC Clock/Temperature Support and Relay/Demo Box Circuit**