



## **Inquiry-Guided Learning (IGL) in Graphical Communications Course**

**Dr. Lulu Sun, Embry-Riddle Aeronautical Univ., Daytona Beach**

Dr. Lulu Sun is an associate professor in the Department of Freshmen Engineering at Embry-Riddle Aeronautical University, where she has taught since 2006. She received her B.S. in Mechanical Engineering from Harbin Engineering University at China in 1999, and her Ph.D. in Mechanical Engineering from University of California at Riverside in 2006. She is a professional member of the Society of Fire Protection Engineer, and a member of American Society of Engineering Education, and Society for the Advancement of Material and Process Engineering.

**Prof. Christopher D Grant, Embry-Riddle Aeronautical Univ., Daytona Beach**

# **Inquiry-Guided Learning (IGL) in Graphical Communications Course**

## **INTRODUCTION**

Inquiry-Guided Learning (IGL) is an active learning technique which promotes students critical thinking through guided independent investigation of complex problems without a single solution, which has been studied and implemented by many researchers in science and engineering fields [1-8]. It is believed that IGL can provide an opportunity to the students to explore their desires and consequently enhance students' learning experience in the classroom. Graphical Communications, as a common course taught at first-year undergraduate level at Embry-Riddle Aeronautical University is designed to familiarize the student with the basic principles of drafting and engineering drawing, to improve three dimensional visualization skills, and to teach the fundamentals of a computer aided design program (CATIA). Faculty members show students step by step how to build a model and make sure they can follow and understand the procedure. However, students' ability to use this knowledge and comprehension to explore real engineering design is unknown.

This paper describes how to incorporate the IGL into the Graphical Communications course, and shows how students are engaged to learn at a higher level of the Bloom's taxonomy [9-11] by implementing sustainable design final projects. Students work in teams to collaboratively collect information, define and analyze the problems, and seek the effective solution. Instead of following faculty member's instruction to passively complete the model design, students have an opportunity to apply the skills they learned in class to solve the real-world problem, and to think as an engineer. IGL introduced a greater level of excitement and enthusiasm by allowing students to explore the topics of personal interest to themselves, therefore it enhanced their understanding of the concepts learned in the classroom. The grading rubrics for the written report and oral presentation were given to the students to assess the team's performance. The phase reports must be turned in on time to report the team's progress. Students need to follow the suggestions on the graded phase reports to improve the subsequent updates. In addition to the instructor's grading rubric, peer evaluation and the team evaluation sheets were used to determine each team's final grades as well. Their oral and written communications, ability to work in team, problem solving, information collection, and project management skills have been improved in IGL environment.

## **Current Curriculum and Course Structure**

The goal of the Graphical Communication course is to familiarize the student with the basic principles of drafting and engineering drawing, to improve three-dimensional visualization skills, and to teach the fundamentals of a computer aided design program. After course completion, students will know the character and application of the various lines used in engineering drawing; be able to relate a scaled drawing to actual size and be able to produce drawings to scale; develop the ability to make acceptable freehand sketches with special understanding of the importance of proportions; know the principles of orthographic projection and apply these principles to construct multi-view drawings; understand the principles of isometric projection

and apply these principles to isometric drawings; understand and draw auxiliary views; understand and draw interior view of an object as a section view; develop the techniques and rules of dimensioning and tolerances, and be able to apply these skills to a drawing; be able to read and understand a basic blue print; be able to understand and use CATIA as a computer aided drafting tool to produce multi-view, isometric, auxiliary and section views.

As a three-credit-hour semester course, students meet the instructor twice a week with each class lasting two hours. The first hour of each class is the scheduled lecture time and after the lecture, students are allowed to use the rest of class time to ask questions and complete their assigned homework. During the 14-week semester, students learn the principle of orthographic projections and apply the principles to multi-view drawings by hand in the first four weeks. CATIA, a 3-D computer aided drafting tool, is introduced after the hand drawing, followed by auxiliary views, section views, dimensioning, and tolerances. A final individual assembly project is given to the students to test their problem solving skills under the direction of the instructor. Students need to complete at least ten parts and assemble them following the constraint requirements. Figures 1 and 2 show the exploded and 3-D view of two previous individual projects.

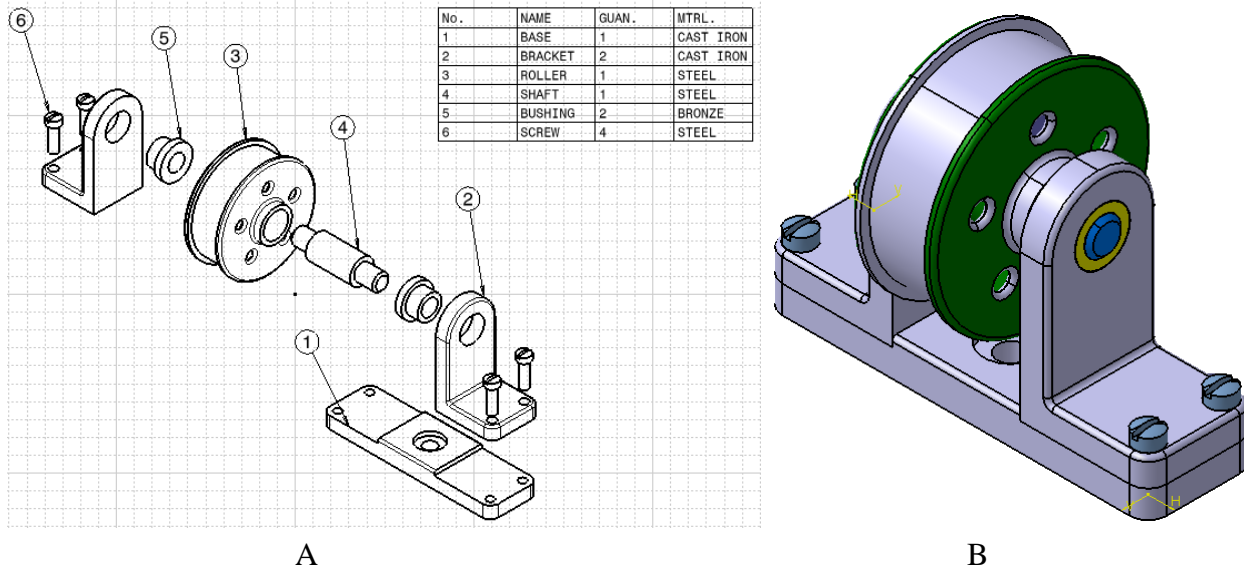
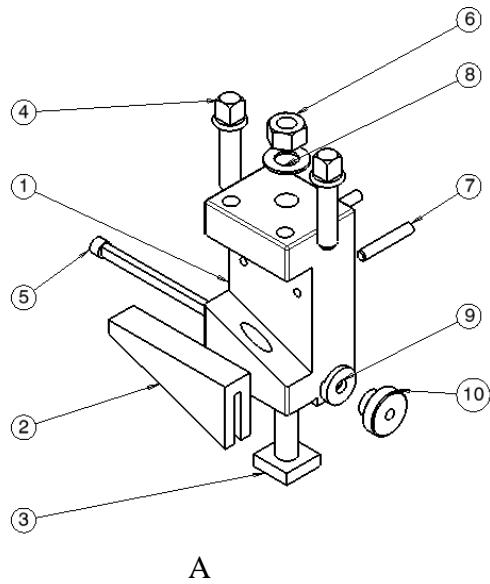

Figure 1 A: Exploded view of the roller guide, B: 3-D view of the roller guide



PART #	PART NAME	REQ'D	MAT
1	TOOL POST BODY	1	CI
2	WEDGE	1	SAE 1045
3	BOLT	1	SAE 1040
4	TOOL POST SCREW	2	SAE 1040
5	ADJUSTING SCREW	1	SAE 1040
6	HEX NUT	1	-
7	SET SCREW	2	SAE 1040
8	WASHER	1	SAE 1040
9	WASHER	1	SAE 1040
10	ADJUSTING NUT	1	SAE 1040

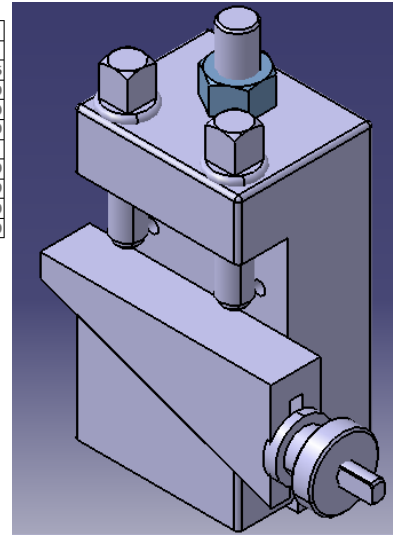

Figure 2 A: Exploded view of the tool post, B:3-D view of the tool post

The end of course evaluation found that, students could follow the directions and accomplish the individual project on time. However, they felt a guided project lacked challenge, and that they would like to design a more complex model by themselves. According to the Bloom’s taxonomy, a guided individual project is considered as an application which can be used to test student problem solving ability as well as satisfying ABET requirement. However, at this level students could not transfer material learned in the classroom to real life situations [12]. They would be more frustrated when they are confronting an open ended design [12]. To change this situation, an open ended team design project was initiated starting the spring semester of 2011. Students could choose to design an existing product from today’s market, then consider how to improve it by incorporating sustainability into their design. Working in self-formed teams of three or four they are expected to use considerable skills learned in the class or by themselves to achieve their own goals with minimum assistance from their instructor. The students’ design is evaluated by their peers and the instructor against a defined specification. It is expected that students could transfer the classroom learning to real-life situations after the completeness of the final project.

### TEAM PROJECT OUTCOMES

There were 26 students enrolled in the spring of 2011, 35 students enrolled in the fall of 2011, 48 students enrolled in the spring of 2012, and 90 students enrolled in the fall of 2012 in the course for this study. As a team of three or four, students were able to choose their design partners and finished their design project within three weeks. The teams needed to first present their design idea to the instructor for approval to make sure that each team has a unique design product, it was of sufficient complexity for a final project, and there is no duplicate design. Students must do a certain amount of research to include the up-to-date technology in their product to emphasize sustainable design and cost efficiency. The product must involve new design and must not be available in today’s market with each assembled product needing to include at least ten parts and each part designed individually. The role of the instructor is as a facilitator to ensure student projects delivered on time and the guidance is limited to the minimum. All dimensioned drawing sheets, 3-D part models, and power-point slides must be submitted on Blackboard before the beginning of the last day of the class. On the last day of the class, students

dress up to present their work as a team. Each presentation lasts 8-10 minutes, and is followed by 2-minutes Q&A time. Peer evaluation and team evaluation rubrics were given to the students to evaluate their peers work, and team. At the end of the presentation, the instructor summarizes the student projects. A survey was implemented to collect students' feedback regarding their satisfaction with the final project, and their comments on how to improve the delivery of the final project.

During the four semesters, there were a total of 58 projects designed by 199 students. Some project topics are listed in Table 1. Figure 3-6 show the exploded view and 3-D view of student team projects. Starting in the spring semester of 2012, besides the above assigned tasks, students were required to submit two sets of the design files. One is the original design based on the current existing product in the market, the other one is the redesigned model to show the sustainable design. Students were also required to submit a written report as a team to document their research findings, design process, timeline, and cost analysis. Each student also needed to submit the individual logbook to document his/her work schedule and the tasks finished following their team timeline.

Eco-friendly Skateboard	Sun-go Skate	A future bicycle	Eco-friendly bicycle	User-friendly fire extinguisher	Monitor mount
Better keyboard	CAD mouse	Fold-out-desk office chair	Space Relay Power System	Comfortable office chair	Wheeled luggage
Rocket board	Light year Jetpack	Eco Cruiser	Hover board	Microscope	Recycling optimizer
Self-powered gym bike	Hovercraft	Solar powered wheelchair	Plasma propelled Spacecraft	Energy efficient fan	Floor lamp

Table 1. Student projects list.

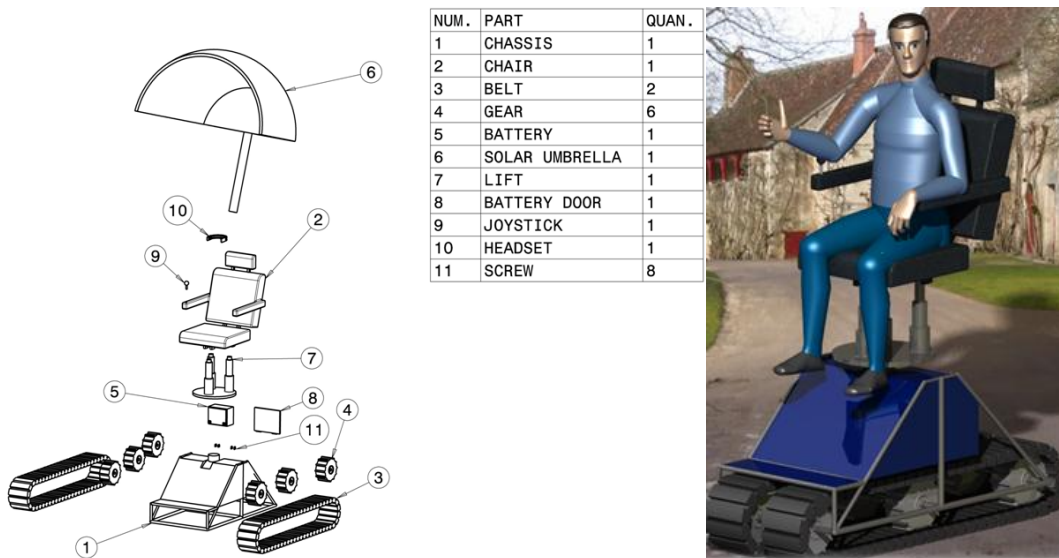

A

B

Figure 3 A: Exploded view of solar powered wheelchair, B: 3-D rendered solar powered wheelchair

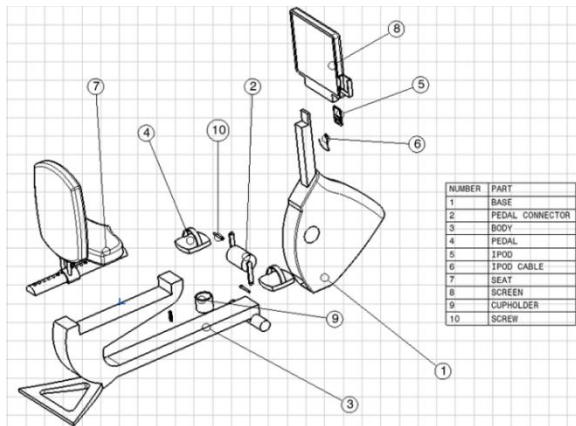

A

B

Figure 4 A: Exploded view of self-propelled gym bike, B: 3-D view of self-propelled gym bike



A

B

NUMBER	NAME	MATERIAL	QUANTITY
1	NOZZLE	RUBBER	1
2	SIPHON TUBE	FIBERGLASS	1
3	TANK	FIBERGLASS	1
4	HANDLE	ALUMINUM	1
5	BUTTON	RUBBER	1
6	SAFETY PIN	ALUMINUM	1
7	VALVE STEM	BRASS	1
8	PRESSURE GAUGE	GLASS	1
9	SPRING	STEEL	1
10	NOZZLE CLASP	PLASTIC	1

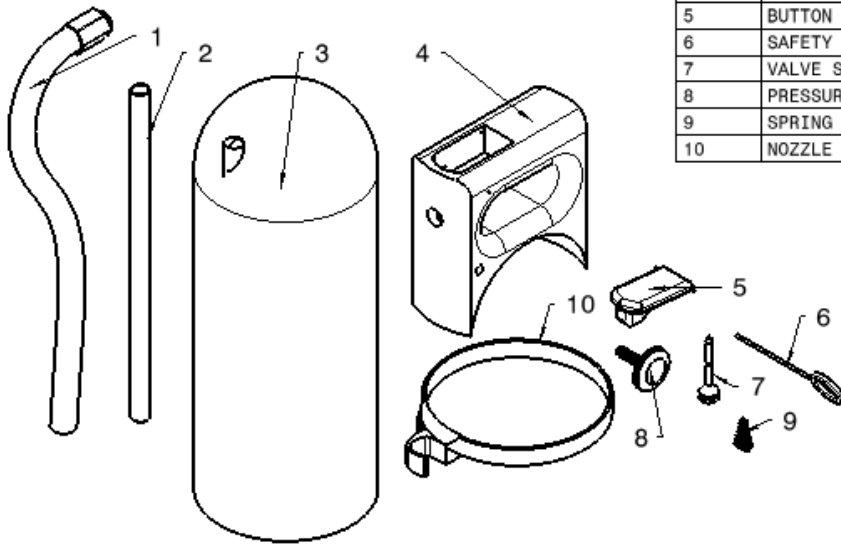

C

Figure 5 A: Original fire extinguisher in the rendered picture, B: Redesigned fire extinguisher, C: exploded view of the redesigned fire extinguisher



A

B

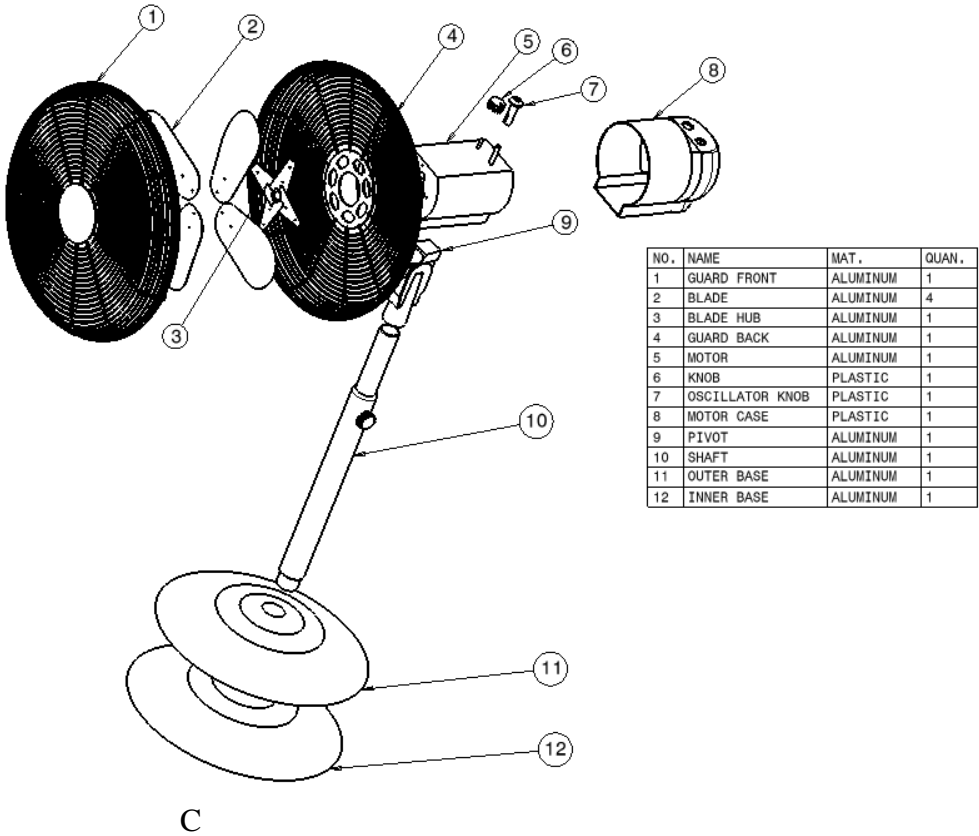

Figure 6 A: Original fan in the rendered picture, B: redesigned fan, C: exploded view of the redesigned fan

**ASSESSMENT**

A students-satisfaction survey was implemented at the end of each semester to collect students' feedback regarding the team project. On average 74% students complete the survey each semester. Final project satisfaction data was analyzed, as shown in the Figure 7. From the graph, we can see that the satisfaction rates were high in the spring (3.36) and fall (3.29) semesters of 2011. Based on student's feedback, the project requirement and design guideline were clearly specified in the fall semester of 2011 as compared to the direction given in the spring semester of 2011. Students rated the final project highly as a chance to understand an engineering design process. They enjoyed designing their own product, working with different classmates, and challenging themselves. They believed that they learned more from the final project by exploring tools which was not covered in class time, teaching themselves the communication skills, working as a team, enhancing their presentation skills. The main complaint was the limited time assigned to the project. Since there were only three weeks left for the project, they felt they could do much better if more time could be assigned. Based on students feedback, starting in the spring of 2012, the project time was extended to eight weeks long. Students were also required to submit periodic progress report, an individual logbook, and a final written report from each team to document their design ideas, process, timeline, cost analysis and research findings. More constraints were added in the fall of 2012 in the report section by asking students to follow a template given to complete the report. Students also needed to submit two different sets of designs. One is based on the product which is existing in today's market, the other one is an



improved model which can involve either new technology, or more user-friendly design to incorporate sustainable design idea into their project. However after adding more workload to the final project, the students satisfaction rate dropped continuously from spring semester (2.81) to fall semester (2.24) of 2012. Students do not appreciate adding report section to the final project, they enjoyed designing process better than documenting it. In addition, a proportion of the students do not appreciate incorporating sustainable/green solutions into the project. Figure 8 shows the level of the likeness of the open-ended project versus the exam. 81% students still preferred the open-ended project, but we can still see that more students preferred working individually instead of working as a team. Since this is a freshmen level course, teamwork is still a challenging work to most of the first-year engineering students.

Some student responses are shown as follows:

- I enjoyed the fact that we got to choose our own topic for the final project. I enjoyed choosing something that was interesting to me but that was also challenging.
- It was cool to work with new people and build something new.
- I liked it, thought it was interesting.
- The final project was great!
- More time so that students can create more complex products.
- More defined parameters as to what needs to be turned in and what is expected of the presentation.
- I wish that we could make our own design and it doesn't require to be eco-friendly. Not all students like eco-friendly products.
- The report asks for way too much. The CATIA project itself should be all.
- Allow for the option of individual or groups because some people would always rely on their teammates to do all the work

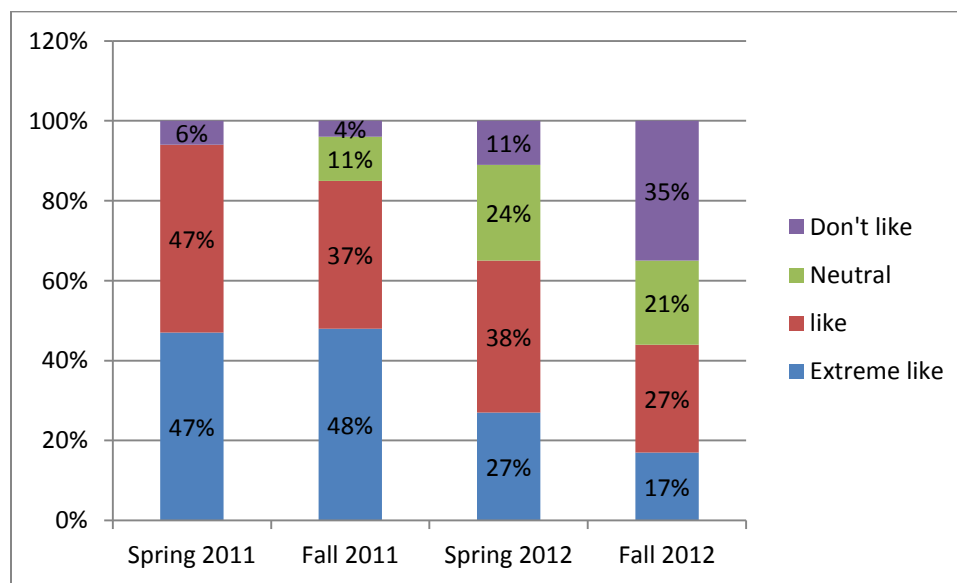

Figure 7. Students final project satisfaction analysis (1- don't like, 2- neutral, 3- like, 4- extremely like)

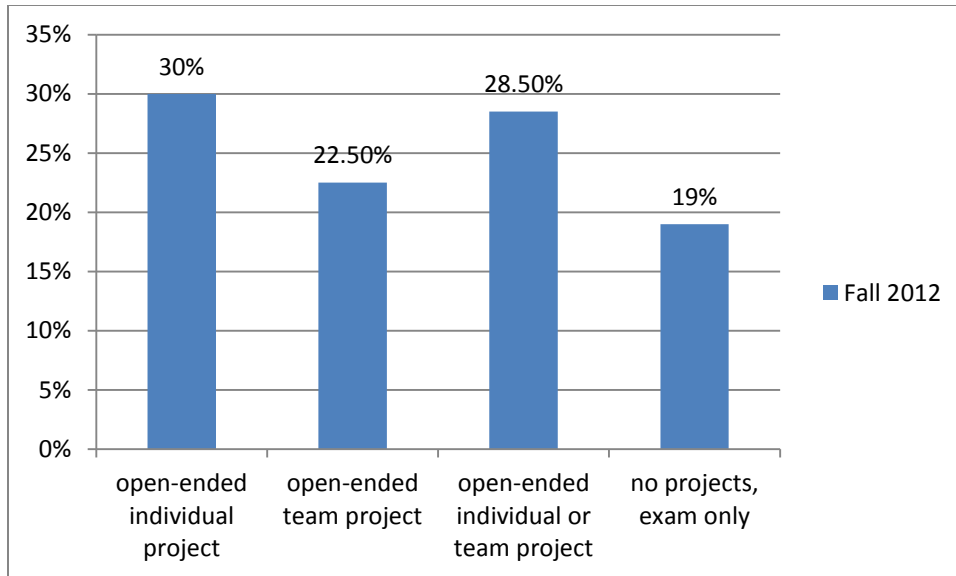

Figure 8. Open-ended project likeness analysis in the fall of 2012

There are many challenges to successfully implement IBL into a freshmen-level course with design components. Some of the most significant challenges are listed below, which needs to be considered and an effective solution found to successfully incorporate IBL.

- Communication problems in the team, which needs the instructor to pay attention and solve as early as possible
- Picking up an appropriate topic is challenging to the students
- Open-ended projects maybe overwhelming to some students who still like to follow the instructor's direction
- Time management is still a big issue to most of the freshmen
- Self-seeking solutions is frustrating to the students
- Students need to adjust to solve real-world complex problem rather than the simple homework problems
- Teamwork is still a challenge to most of the freshmen
- It is hard to balance the amount of constraints and the creativity level in the project requirements

### CONCLUSION

This paper has presented a transition from a guided individual project to a team-based open ended project in the graphical communication course. The open-ended team project has fostered learner-centered activities. It gave students opportunities to inquiry, design, assemble, and present their work, which were not provided to previous classes. An end-of-semester survey was implemented to collect student's feedback regarding the team project initiation. 74% students filled out the online survey at the end of each semester from spring of 2011 to the fall of 2012. Students have responded positively to the final team-based project design. It is believed that by implementing IBL into the engineering design course, students would gain more solid knowledge and improve their ability to transfer the classroom material to real-life product design. Based upon student feedback, more time will be given to the students to produce more

complex models. A better articulation of the final project objective and rubric are needed to provide a detailed explanation regarding the submitted files and presentation expectation. The discussion of the philosophy and the intent of the sustainable design should be added in the lecture to help address the importance of the IBL in which some students may not realize. More active learning activities should be included in the class time to help students get familiar with each other and help build a better and stronger team with better communication.

### REFERENCES

- [1] Thacker, B., K. Eunsook, K. Trefz, and S. Lea, "Comparing Problem Solving Performance of Physics Students in Inquiry-Based and Traditional Introductory Physics Courses," *American Journal of Physics*, Vol. 62, No. 7, 1994, p. 627.
- [2] Heflich, D., J. Dixon, and K. Davis, "Taking It to the Field: The Authentic Integration of Mathematics and Technology in Inquiry-Based Science Instruction," *Journal of Computers in Mathematics and Science Teaching*, Vol. 20, No. 1, 2001, p. 99.
- [3] Schlenker, R., and K. Schlenker, "Integrating Science, Mathematics, and Sociology in an Inquiry-Based Study of Changing Population Density," *Science Activities*, Vol. 36, No. 4, 2000, p. 16.
- [4] Buch, N., and T. Wolff, "Classroom Teaching through Inquiry," *Journal of Professional Issues in Engineering Education and Practice*, Vol. 126, No. 3, 2000, p. 105.
- [5] Biernacki, J.J. and C.D. Wilson, "Interdisciplinary Laboratory in Advanced Materials: A Team-Oriented Inquiry-Based Approach," *Journal of Engineering Education*, Vol. 90, 2001, p. 637.
- [6] Stahovich, T.F., and H. Bal, "An Inductive Approach to Learning and Reusing Design Strategies," *Research in Engineering Design*, Vol. 13, No. 2, 2002, p. 109.
- [7] Sundararajan, S., Faidley, E. L., and Meyer, R. T., "Developing inquiry-based laboratory exercises for a mechanical engineering curriculum," *Proceedings of the 2012 American Society for Engineering Education Annual Conference & Exposition, 2012, Session 5155*.
- [8] Trombulak, S. C. , "Merging inquiry-based learning with near-peer teaching," *BioScience*. v45, n6, p412 (1995).
- [9] Bloom, Benjamin.S. *Taxonomy of educational objectives: Handbook I: Cognitive domain*. New York; Toronto: Longman, 1956.
- [10] Felder, Richard M. and Rebecca Brent., "The ABC's of Engineering Education: ABET, Bloom's taxonomy, Cooperative Learning, And So On," *Proceedings of the 2004 American Society for Engineering Education Annual Conference & Exposition, 2004, Session 1375*.
- [11] Jones, Karl O., Janice Harland, Juliet M.V. Reid and Rebecca Bartlett, "Relationship Between Examination Questions and Bloom's Taxonomy," *39th ASEE/IEEE Frontiers in Education Conference, 2009, Session W1G*.
- [12] Farris, John and Paul Lane, "Reality Learning: Teaching Higher on Bloom's Taxonomy," *Proceedings of the 2005 American Society for Engineering Education Annual Conference & Exposition, 2005*.