

It Does Not Have to Be Rocket Science—But Sometimes It Is

Stephen T. McClain
Mississippi State University
Department of Mechanical Engineering
P.O. Box ME
Mississippi State, MS 39762
mcclain@me.msstate.edu

Abstract

The efforts of two student groups in ME 4731—Experimental Techniques II at Mississippi State University are presented. In Experimental Techniques II, groups of three or four students are required to choose an experimental objective, design and build an apparatus to achieve the objectives, run an experiment to reach their objectives, quantify the uncertainty associated with their results, and discuss the results of their experiments in written and oral reports. To maintain a high level of student interest, a great amount of freedom is given to the students in choosing experimental objectives. In the Spring 2001 semester, two groups selected two interesting, unusual, and ambitious experimental objectives. One group chose to design and calibrate a model-rocket-engine test stand and use it to validate the manufacturer's specifications of maximum thrust, average thrust, and total thrust time of a model rocket engine type. The second group chose to build and test a potato gun to determine its chemical efficiency. The effects of air-fuel ratio, barrel diameter, and barrel length were explored. Each of the groups faced many problems and challenges in achieving their objectives. The problems, the innovative solutions, and the surprising results of both projects are discussed. The benefits seen in ME 4731 of allowing students to choose their own projects are also briefly discussed.

Introduction

The undergraduate laboratory sequence in mechanical engineering at Mississippi State University consists of ME 3701—Experimental Orientation, ME 4721—Experimental Techniques I, and ME 4731—Experimental Techniques II. Each of the laboratories is worth one hour of credit. In ME 3701, students study engineering measurements, transducers, and data acquisition systems. In ME 4721, students learn uncertainty analysis and experimental design using uncertainty-analysis techniques. In ME 4731, the students are required to use the information acquired in ME 3701 and ME 4721 to design, build, and run experiments. The students must then report the results of their experiments in formal written and oral reports.

Students normally run four experiments in ME 4731. Two experiments are two-week experiments and two are five-week experiments. In the two-week experiments, students in groups of three or four are assigned an existing experimental apparatus and an experimental objective. The purpose of the two-week experiments is for the students to demonstrate the ability to use an existing apparatus and design an experimental procedure to achieve an

objective. The students must then execute their procedure, analyze the data, determine uncertainties, and report the results.

In the five-week projects, students in groups of three or four choose an experimental objective. The students are given a list of about 30 experiments that have been approved as five-week projects. Half of the projects concern material behavior or solid mechanics, and half of the projects are related to heat transfer or fluid mechanics. The groups must complete one materials/solid mechanics five-week project and one heat transfer/fluid mechanics five-week project.

To complete each five-week project, the groups must complete 1) a brief oral proposal, 2) a written proposal, 3) a formal oral presentation, and 4) a formal written report. One week after the project is assigned, the group is required to present a fifteen-minute oral proposal. In the brief oral proposal, the students in a group must discuss the theory of the projects, the construction of the apparatus, and the requirements for the instrumentation. This exercise serves two purposes. The first purpose is to require the students to start researching their topics early. The second purpose is to help the students maintain focus on their experiments and ensure that they have not embellished the experiment so that it cannot be completed in the remaining four-week period. Students often over-design apparatuses or require expensive or unnecessary instrumentation. Thus, the oral proposals help to keep the students focused and the experiments simple.

Two weeks after the assignment of the project, the groups are required to submit a written proposal. In the proposals, the groups are expected to select the apparatus construction, materials, instrumentation, and test plan that minimize the expected uncertainty in their result. Students are expected to use uncertainty analysis with the appropriate physics to achieve the minimum uncertainty possible with the resources available on campus.

Five weeks after the assignment of the project, the groups are then required to submit the formal oral presentation and the formal written report. Presentations must be created using Microsoft PowerPoint and presented electronically. The formal written reports must be created using Microsoft Word and must conform to style, format, and content specifications. The formal reports must present the experimental theory, the final experimental design, the results of the experiment, and the uncertainty analysis results.

Because many of the experiments are performed every semester and because some students find the experiments on the approved list unappealing, the students are encouraged (and sometimes enticed with bonus points) to create original experiments. The students are encouraged to find a topic that interests each group member. If the students are interested in a topic outside of mechanical engineering, they are encouraged to go to other departments and ask for assistance.

In some instances, groups choose experimental objectives that are ambitious and require more than the allowed five-weeks. If the instructor finds that the objective is very ambitious, the groups are allowed to complete two five-week projects on one experimental objective. While the

two-five week projects are generally used to expose students to both materials/mechanics and thermal/fluid projects, if the students are ambitious and highly interested in one objective, they are allowed to conduct both projects to complete two five-week projects on one experimental objective.

In the Spring 2001 semester, two groups chose two interesting and very ambitious experimental objectives. One group asked to build a model rocket engine test stand and test the performance of a model rocket engine. Another group chose to test the effects of barrel shape on the efficiency of a potato gun.

Since each project required considerable effort, both main topics were separated into two five-week projects. The objective of the first five-week project of the “test stand” group was to design, build, and calibrate a load cell for the test stand. In the second five-week project, the “test stand” group was to test the manufacturer’s specifications of maximum thrust, average thrust, and total thrust time for a given model rocket engine type. The objective of the first five-week project of the “potato gun” group was to determine the chemical efficiency of one barrel size versus the mass of fuel sprayed into the combustion chamber. In the second five-week project, the “potato gun” group was to change the barrel diameter and length to determine what type of barrel shape produces the best chemical efficiency. The following two sections of this paper discuss the problems encountered by the groups, the innovative solutions, and the results of the groups’ projects.

Model Rocket Test Stand

The first group of students chose to test three “C6-5” model rocket engines for maximum thrust, average thrust, total thrust time, and delay time between engine ignition and parachute charge ignition. From the manufacturer’s specifications of the engine type, the engines were expected to produce a maximum thrust of 3.44 lb_f, an average thrust of 6 N (1.35 lb_f), a total thrust time of 1.7 seconds, with a 5.0 second delay between engine ignition and parachute charge ignition. As discussed earlier, the main objective of the project was split into two five-week projects. The objective of the first five-week project was to design, build, and calibrate a load cell for the tests. The objective of the second five-week project was to test a set of model rocket engines and compare the actual engine performance to the manufacturer’s specifications.

The students had two main concerns regarding the test stand configuration. The engine must maintain the same orientation, or thrust direction, during the tests, and the tests measurement must not be affected by the loss of mass of the engine during firing. If the rockets were mounted on the end of a cantilevered beam, for example, as the force is applied to the edge of the beam, the end of the beam would rotate and cause the force of the engine to not be perpendicular to the cantilevered beam. If the rockets were mounted such that they fired upward or downward during the test, also for example, the effect of gravity and the changing weight of the rocket could not be easily extracted from the test results.

To satisfy the configuration constraints, the students chose to base their design on a vertical beam with rigid supports, as shown in Figure 1. With the engine mount in the center of the beam, the force of the rocket engine would always be perpendicular to the beam, and with the horizontal engine orientation, the load cell would not be affected by the loss of mass of the rocket engine. A strain gage was to be placed near one of the rigid supports to measure the thrust. A drilled and bored out block of aluminum 2024-T6 was attached to the beam as an engine mount.

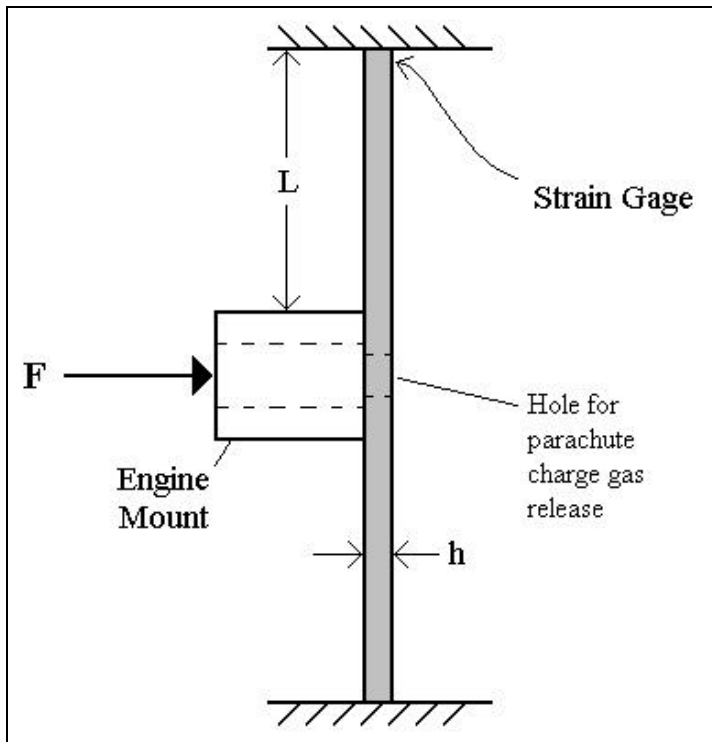

Figure 1. Load Cell Schematic Using a Fixed-Fixed Beam

The most important design aspect of the test stand was the size of the beam. The beam needed to be big enough to withstand the forces of each test without yielding or breaking, but the beam must be small enough so that the strain experienced by the strain gage is large enough to measure with accuracy. To size the beam, the students applied a yield criterion at the beam supports where the bending moment on the beam is a maximum. The beam material was low carbon steel.

The students assumed that the width of the load-cell beam should be around three times the diameter of the rocket engine to abate torsional vibration. The students then searched for a mount for the load-cell beam. The students found a piece of 8 in. by 4 in. box beam in a scrap heap to use as a load-cell mount. The length of the beam was set to the maximum width of the box beam, 8 in.

To size the thickness of the beam, the students then needed to determine the maximum load that would be experienced by the beam during testing. This was not a simple task. The model rocket engines chosen for testing contained a parachute charge. After burning, the engines fire the parachute charge to blow off the nose cone of the model rocket releasing a parachute for the safe descent back to the ground. Unfortunately, this parachute charge could not be stopped during the engine tests, and the students were unable to find and purchase model rocket engines that did not have the parachute charge.

To relieve the force of the parachute charge, the students decided to drill a hole through the beam to permit the combustion gases of the parachute charge escape. This lowered the force of the parachute charge, but the students still had no estimate of the magnitude of the force of the parachute charge. After extensive research and considering the purpose of the parachute charge, the students finally decided to design the beam to withstand a maximum force of 100 lb_f.

For the experimental design and analysis, the students assumed that the strain gage was placed at the very edge of the beam. For this idealized location, the force applied to the beam was found using equation (1).

$$F = \frac{2bh^2 E \epsilon}{3L} \quad (1)$$

where ϵ is the strain, F is the force applied to the beam, L is the length between the end of the beam and the edge of the engine mount, b is the width of the beam, h is the height of the beam, and E is the modulus of elasticity of the beam. The students were required to use a Wheatstone bridge circuit to measure the strain in the first part of the project. Using a Wheatstone bridge, the force applied was found using equation (2).

$$F = \frac{2bh^2 E \Delta V_o (R_g + R_d)^2}{3LG V_{in} R_g R_d} \quad (2)$$

where ΔV_o is the change in output voltage of the bridge, R_g is the resistance of the strain gage, R_d is the resistance of the a dummy gage on the arm of the bridge with the strain gage, G is the gage factor of the strain gage, and V_{in} is the input voltage to the bridge.

In the proposal for the first five-week project, the students used equation (2) to perform a general uncertainty analysis on the load cell. Based on their analysis, they expected to be able to measure a 3-lb_f load with an uncertainty of ± 0.08 lb_f or less than 3%. Unfortunately, they found that achieving this uncertainty was much more difficult than expected.

At the beginning of the calibration process, the students used a 0-10 V power supply, two multi-meters, a 1-10 lb set of weights, and a laptop computer with a data acquisition card. The students planned to place the series of weights on the load cell, take output voltage readings, then make a linear curve fit of force versus output voltage. During multi-meter testing of the bridge

circuit, the students noticed there was considerable ripple in the input voltage even though the power supply was supposedly “regulated.” This ripple in the input voltage was causing the output voltage to oscillate about ± 20 mV when the expected change in output voltage with 3 lb_f applied was about 6 mV.

The students attached the data acquisition laptop to the bridge circuit in the hopes that it could sample quickly enough to account for the ripple. Incredibly, this made the problem worse! With the data acquisition system attached, the ripple in the input voltage became almost ± 100 mV, and the data acquisition system was not fast enough to negate the ripple. Ground loops were immediately suspected as a cause for the ripple. Both the students and the instructor checked for and attempted to eliminate ground loops and the power oscillations. Unfortunately, nothing helped and even the instructor was stumped.

At this point, the students were instructed to stop the calibration effort and complete the formal reports for the first five-week project. The students had made considerable progress in designing and constructing the test stand. Eliminating the bugs associated with the data acquisition system would have to wait until the second five-week project.

With no improvement in the Wheatstone bridge operation two weeks into the second five-week project, the students found a strain indicator with voltage output that was not being used. The strain indicator was owned by one of the research groups at Mississippi State University, and after considerable begging, the students were allowed to borrow the strain indicator to complete the project. With the strain indicator installed, the strain measurements were very steady, and the calibration process was completed.

The students then turned their attention to building the firing system and the data acquisition program. The firing system was a simple 9 V battery. One lead from the firing circuit was held to the negative post on the battery with the operators thumb. To fire the rocket, the other lead was placed on the positive post of the battery. The data acquisition program was also very simple. When the program was run, the laptop sampled the strain indicator output voltage at a rate of 500 samples per second for 10 seconds and then wrote the data to a file. The students completed tests on three C6-5 model rocket engines. A digital image taken during one of the tests is shown in Figure 2.

The test stand performed very well, and the results were interesting. Only one of the three engines performed better than the manufacturer’s specifications on max thrust and average thrust, but all burned longer than the manufacturer’s specified burn time. A typical thrust curve is shown in Figure 3 along with the manufacture’s specification for engine performance. The maximum thrust produced by this engine was 3.05 lb_f versus 3.44 lb_f from the manufacturer’s specifications. The average thrust was 1.1 lbf versus 1.3 lbf from the manufacturer’s specifications, but the engine burned for 1.9 seconds which was 0.2 seconds longer than the manufacturer’s specified burn time. The parachute charge, which is not shown in the plot, occurred at 4.7 seconds after ignition or 0.3 seconds earlier than the manufacturer’s specifications.

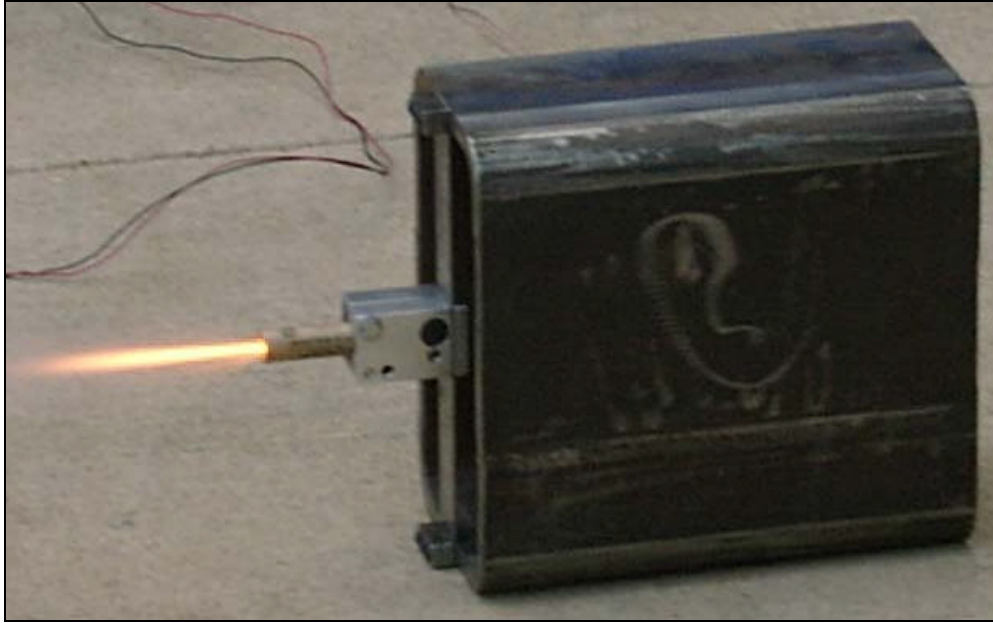

Figure 2. Digital Image of Model Rocket Engine Test

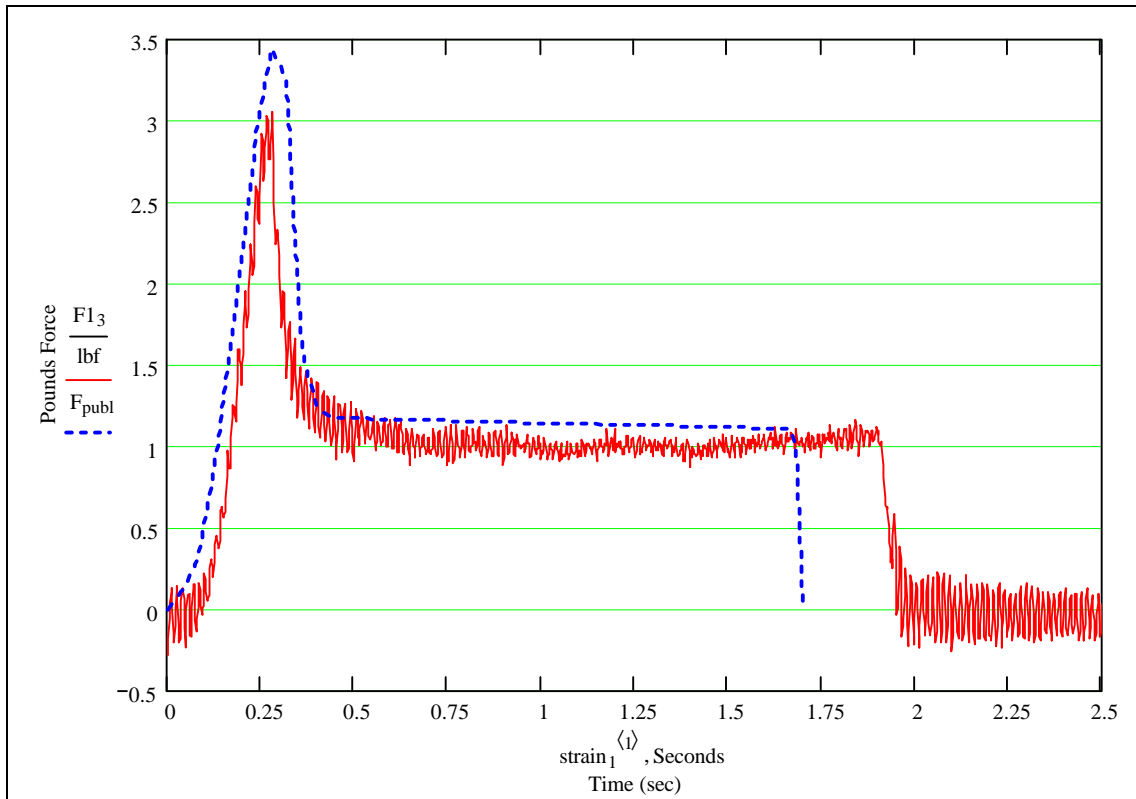

Figure 3. Typical Thrust Curve for C6-5 Model Rocket Engine

Efficiency of a Potato Gun

The second group tested a potato gun for efficiency. The potato gun constructed and studied in this experiment consisted of a 3" elbow as a combustion chamber, a 3" end cap, a reduction fitting, and a length of pipe for a barrel. All components were PVC, and all fittings were threaded. A schematic of the potato gun construction is shown in Figure 4.

Since potato guns are dangerous, precautions were taken to ensure safety during the potato gun firing. Shown in Figure 4, a remote firing system was constructed. An igniter from a gas grill was installed in the combustion chamber. A push-button ignition system with a thirty-foot cord was used to fire the potato gun. During firing, the operator was shielded from the gun, and the spotters were at least fifty feet away during a test.

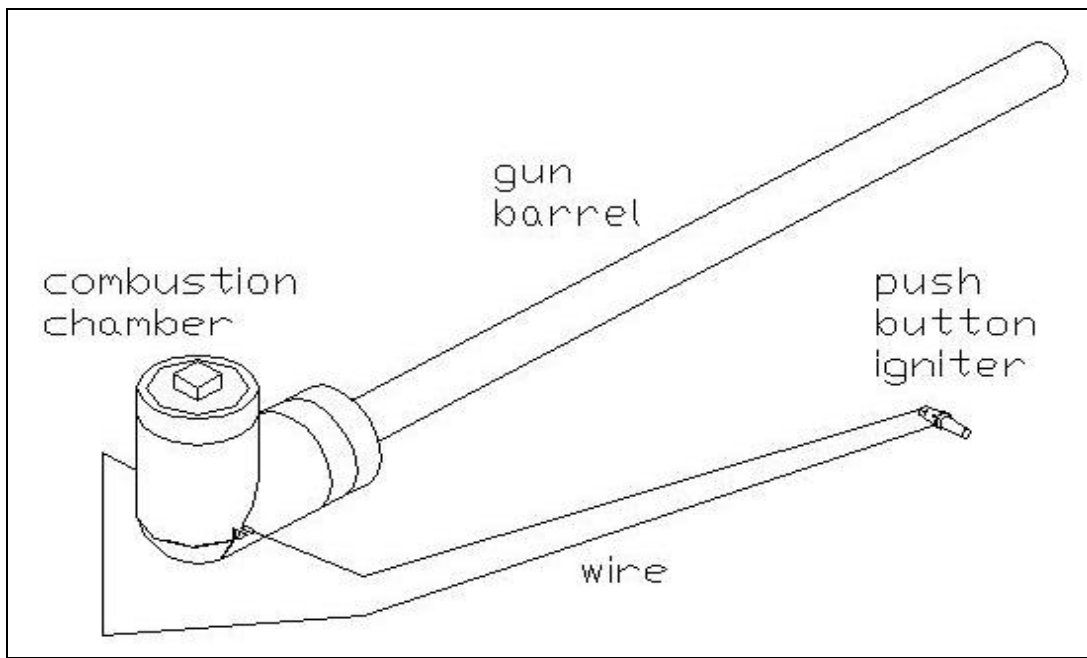

Figure 4. Schematic of Potato Gun Construction

To fire the potato gun, a potato was inserted into the barrel. The potato was pushed to the back of the barrel using a “ramming rod.” The end cap of the combustion chamber was removed, and fuel was sprayed into the combustion chamber. The fuel used for this experiment was AquaNet hairspray (a common fuel for potato-gun enthusiasts). After the firing range was cleared, the operator took shelter behind a blast deflector, noted the positions of the spotters, and then fired the gun. For each firing of the potato gun, an intricate method was used to determine the efficiency of the gun.

The First Law thermodynamic efficiency is defined as the energy output divided by the energy input. For the potato gun, the students defined the chemical efficiency of the potato gun, h , as the initial kinetic energy of the potato as it leaves the gun, KE_{pi} , divided by the chemical energy of the fuel, Q_f .

$$h = \frac{KE_{pi}}{Q_f}$$

Substituting the functions for the initial kinetic energy of the potato and the chemical energy of the fuel results

$$h = \frac{\frac{1}{2}m_p v^2}{m_f Q_{HV}} \quad (3)$$

where m_p is the mass of the potato, v is the exit velocity of the potato, m_f is the mass of fuel in the chamber of the potato gun, and Q_{HV} is the heating value of the fuel.

While equation (3) may seem simple enough with only four variables, the students had to make assumptions and/or estimations about each variable in equation (3). The students understood that the objective of their first five-week project was to obtain repeatable results using the potato gun. They further understood that because of some assumptions that they would have to make, there would be some systematic uncertainties or biases appearing in the results. Their objective was to minimize these systematic uncertainties or choose methods that created the same bias in every test of the potato gun. Thus, the biases would cancel out when comparing individual tests of the potato gun.

For the mass of the potato, the students originally attempted to cut and weigh each potato in the laboratory before taking the potatoes to the field for testing. The students then noticed that because of evaporation, the potatoes lost considerable mass when left in air after peeling. If peeled and shaped before insertion into the potato gun, the potatoes often did not fit in the barrel or did not seal the barrel tightly. To overcome these problems, the students decided to use a field procedure to evaluate the mass of the potato in the gun.

The students realized that if they forced the potato into the barrel, then the potato would always have a known diameter, the inner diameter of the barrel. The volume of the potato in the gun would be the inner area of the barrel times the length of the potato. The end of the barrel was beveled so that it was sharp enough to cut through the potatoes. For each potato tested, the potato ends were cut off with parallel cuts. The length was measured between the parallel cuts. The potato was then forced into the barrel perpendicular to the cuts on the ends of the potato. As the potatoes were forced into the barrel, all material outside the area of the barrel was cut away leaving a cylinder of potato in the gun. Thus, the volume of potato in the gun was the inner area of the barrel times the length of the potato after being cut.

In the laboratory, the students used the barrel to cut several potatoes into cylinders. They quickly weighed the cylinders and measured the cylinders' dimensions. From these measurements, the students determined the density of the potatoes. The average density of the potatoes was

determined to be $1.188 \text{ g/cm}^3 \pm (0.040 \text{ g/cm}^3)$. With the density known, the mass of the potato was determined using equation (4).

$$m_p = \frac{\rho}{4} d^2 l \rho_p \quad (4)$$

where d is the diameter of the potato, which equals the inner diameter of the barrel, l is the length of the potato as measured in the field with the ends cut, and ρ_p is the density of the potato. The exit velocity of the potato was determined using simple dynamics. A schematic of the exit velocity determination is shown in Figure 5. Assuming constant gravitational acceleration, g , acting in the vertical direction with no drag resistance, a projectile fired at an angle q with a given initial velocity, v , will travel a horizontal distance, s , equal to

$$s = \frac{v^2 \sin(2q)}{g} \quad (5)$$

The students tested the potato gun on a flat section of a farmland owned by the parents of one of the students. They measured the distance each potato traveled using a measuring wheel. The angle with which the potatoes were fired was determined by measuring the rise, H , and the run, L of the barrel. Substituting for the angle in the above equation and solving for velocity yields equation (6) for the exit velocity of the potato.

$$v = \left(\frac{sg}{\sin(2\text{atan}(H/L))} \right)^{\frac{1}{2}} \quad (6)$$

The “potato gun” group encountered several obstructions in determining the amount of fuel in the potato gun. The first major obstacle was determining the chemical formula of the fuel, which was hairspray. The manufacturer of the hairspray would not release the chemical formula because it was proprietary. After an anonymous interview with a chemical engineer over an internet chat line, the students assumed the hairspray was 12% ethyl alcohol by weight with the remainder being water. The students used a heating value of 12,000 BTU/lb_m for ethyl alcohol. While this composition may not be completely accurate, and therefore the heating value may not be accurate, the bias or systematic error created occurs in every test of the potato gun when using the same bottle of hairspray.

The amount of hairspray in the chamber was determined by multiplying the mass flow rate of hairspray from the can by the time the hairspray is sprayed into the chamber of the potato gun. The mass flow rate of hairspray was determined by spraying hairspray into a cup for a given time and weighing the cup before and after the hairspray addition. Over the series of tests, the students found that they had used very little hairspray from the full can and that the mass flow rate of fuel did not change considerably from the beginning to the end of the test.

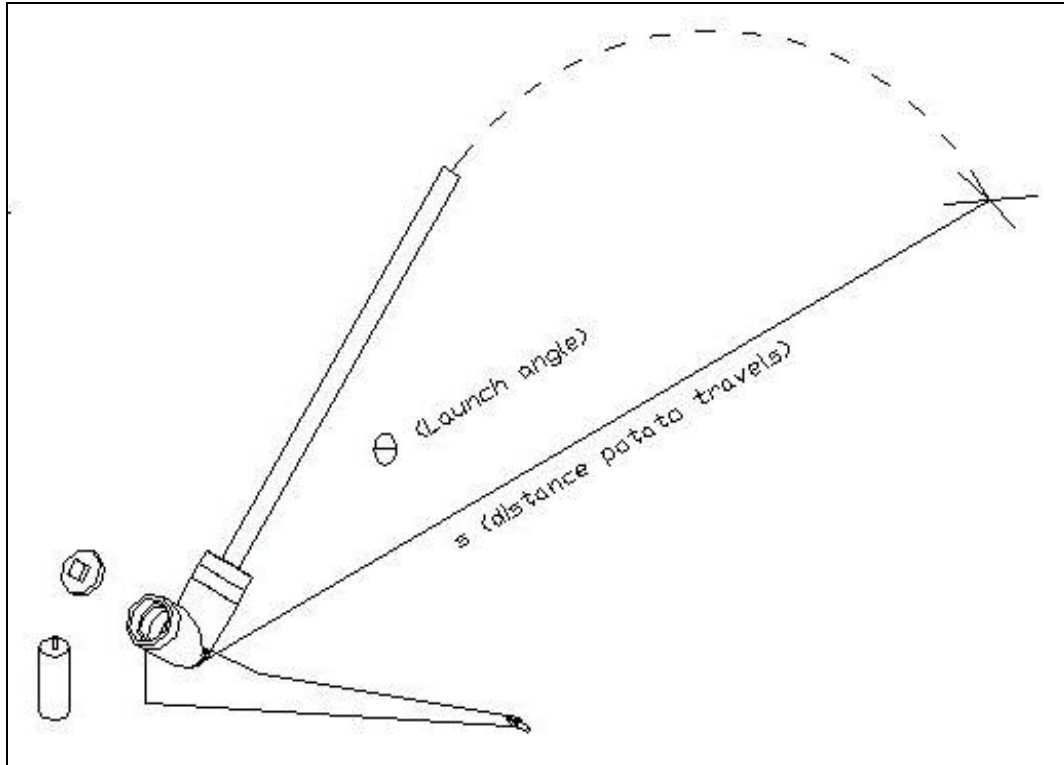

Figure 5. Schematic of Exit Velocity Determination

While there is some evaporation of the fuel as the hairspray is sprayed into the cup, the error caused by this assumption is systematic and will occur for each trial of the potato gun. The expression for determining the mass of the fuel in the combustion chamber is then presented in equation (7).

$$m_f = C\dot{m}_{hs}t \quad (7)$$

In equation (7), m_f is the amount of fuel in the combustion chamber, C is the mass fraction of the hairspray that is combustible (ethyl alcohol), \dot{m}_{hs} is the mass flow rate of hairspray, and t is the time for which hairspray is sprayed into the combustion chamber. Substituting equations (4), (6), and (7) into equation (3) yields an expression for efficiency of the potato gun.

$$\mathbf{h} = \frac{\mathbf{pd}^2 l \mathbf{r}_p s g}{8C\dot{m}_{hs} t Q_{HV} \sin(2\mathbf{atan}(H / L))} \quad (8)$$

For the first five-week project, the group evaluated the efficiency of the potato gun versus the amount of fuel in the chamber with a 54 in. long, 2 in. diameter barrel. The uncertainty associated with each efficiency was also determined. In the second five-week project, the group evaluated a 42 in. long, 2 in. diameter barrel; a 30 in. long, 2 in. diameter barrel; a 54 in. long, 1.5 in. diameter barrel; a 42 in. long, 1.5 in. diameter barrel; and a 30 in. long, 1.5 in. diameter

barrel. Unfortunately, an error in the group's MathCAD worksheet clouded the true experimental results at the time of their final report, but the group did find some interesting conclusions with the corrected data.

The students found no trend in the efficiency with respect to the mass of fuel in the chamber. The students expected to find a trend in efficiency of the potato gun as the fuel mixture ratio passed from fuel rich, to stoichiometric, to fuel lean. Interestingly, this trend was not evident in the data. The most significant trend found in the data was with respect to the mass of the potato fired from the gun. Figure 6 shows the efficiency of all of the barrel shapes with respect to the mass of the potato projectile. Figure 6 demonstrates that as the mass of the projectile increases, the efficiency of the gun increases linearly. Observing equation (3), this makes sense. If the derivative of the efficiency is taken with respect to the mass of the projectile, the result is $v^2/2m_f Q_{HV}$. Since Q_{HV} is a constant and the derivative is found to be constant, this implies that the ratio v^2/m_f must also be constant. Since the square of the velocity is directly proportional to the distance the potato traveled via equation (5), this also implies that the ratio s/m_f is also a constant. Thus, the distance the projectile traveled was directly proportional to the amount of fuel sprayed into the combustion chamber.

Figure 6 shows that the 2 in. diameter barrels were more efficient than the 1.5 in. diameter barrels. This result was solely because the larger diameter allowed potato-projectiles that were more massive. No clear effect of barrel length was found on the efficiency of the potato gun.

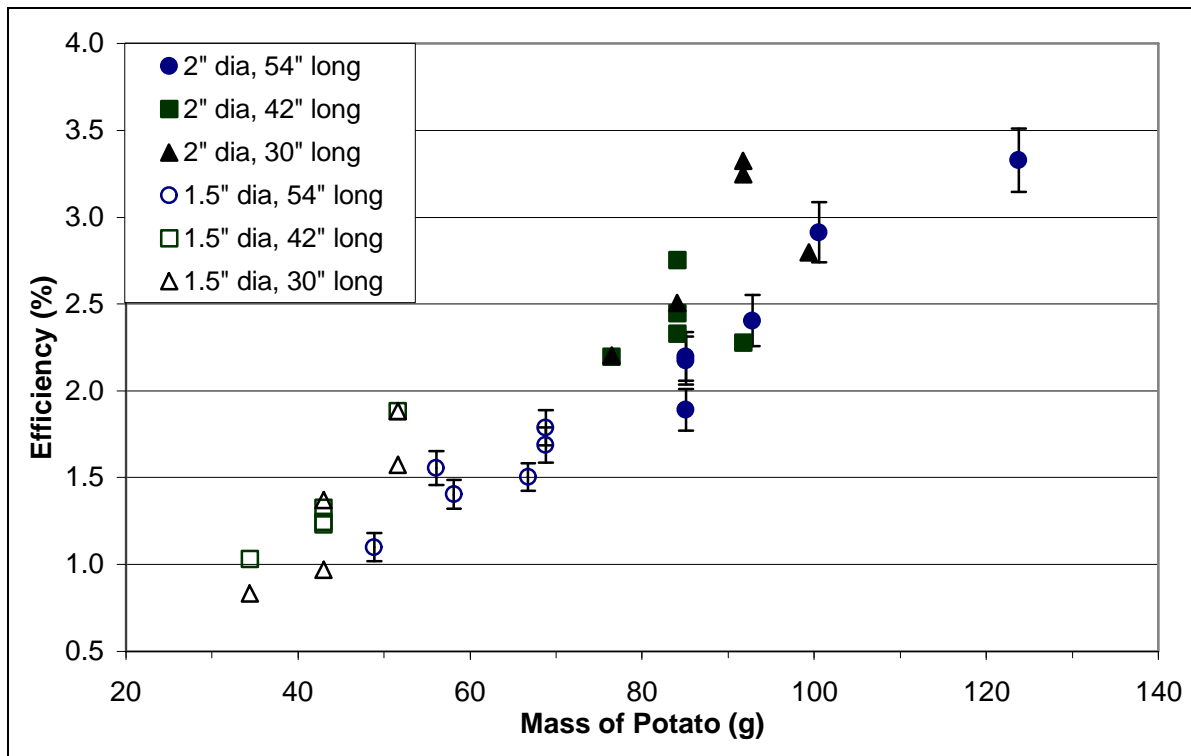

Figure 6. Potato Gun Efficiency Versus Mass of Potato

Figure 6 also displays the uncertainties associated with the efficiency tests for the barrel shape that produced the largest average uncertainty. The maximum uncertainty was determined to be 0.2%. This uncertainty is somewhat misleading because it does not consider the systematic uncertainties associated with concentration of ethyl alcohol in the hairspray, the higher heating value of the ethyl alcohol, and the loss of fuel due to evaporation during the calculation of mass flow rate from the can of hairspray. These uncertainties were not considered because they were assumed constant in each efficiency test of the potato gun and because they should not affect comparative tests with the same apparatus.

Discussion

The results of a group project in which the students were not interested in the objective were not presented. Even without this comparison, the amount of work each group performed is considerable. Each of the groups spent extensive time designing, planning, building, and debugging their experiments as well as analyzing and reporting the results. Because each individual was excited about and interested in the experimental objectives, each student contributed to every phase of the projects.

Examples on the list of standard experimental objectives are 1) plan, design, and conduct an experiment to determine the thermal conductivity of a metal and 2) plan, design, and conduct an experiment to determine the modulus of elasticity, the yield strength, ultimate strength, and percentage elongation of an aluminum alloy. When groups chose objectives from the standard list, the groups often take a “minimalist” attitude toward achieving their experimental objectives, and group performance suffers. Individual participation is another problem often experienced when groups choose objectives from the standard list. When one or more group members is bored by an objective chosen by the other group members, the participation of the bored group member often wanes. This can cause tension in the group and decreased group performance.

Individual participation for the students of the potato gun group was a concern of the instructor in the beginning of the semester. The potato gun group consisted of one A student, one B student, and two C students. The instructor was concerned that the two C students would be bored with an objective from the standard list of experiments. Because of the instructor's concerns, the potato gun group was encouraged to choose experimental objectives of their own interests. The idea to test a potato gun came from the two C students. Because the topic interested each member of the group, individual participation was exemplary. During informal class exit debriefings, no student felt that any group member slacked on the projects.

The facts that group performance increases and individual participation to the group are maximized when the students are interested in their objectives should be obvious. This paper demonstrates how impressive the results can be in a demanding experimental design course when students are interested and motivated. Whether the topic is rocket science or not, the students must be interested!

Conclusions

ME 4731 is a demanding, one-hour experimental design laboratory. Groups of three or four students are required to spend a tremendous amount of time planning, designing, building, and running two large experiments in a semester. The students must then analyze the data, perform a full uncertainty analysis, and present the results in formal written and oral reports. Because of the amount of work involved, the students are encouraged to develop experimental objectives that interest each group member.

When groups choose experimental objectives that do not interest every group member, two problems that often occur are below average group performance and/or unequal individual performances within the group. These two problems rarely occur when groups choose experimental objectives that are new and interesting to each group member. When all group members are interested in and excited about their experimental objectives, group performance often greatly exceeds instructor expectations.

Acknowledgements

The author would like to thank W. Glenn Steele and the Department of Mechanical Engineering at Mississippi State University for their support of these teaching activities. The author would also like to thank B. Keith Hodge, John T. Berry, and Anne S. McClain for their help and suggestions concerning the paper. Lastly, the author would like to thank his students in ME 4731 for their enthusiasm, dedication, and professionalism.

References

“Design and Analysis of a Model Rocket Engine Test Stand,” Project 2 Formal Report, ME 4731, Department of Mechanical Engineering, Mississippi State University, March 2, 2001.

“Measuring the Thrust of a Model Rocket Engine,” Project 3 Formal Report, ME 4731, Department of Mechanical Engineering, Mississippi State University, April 17, 2001.

“Determining the Chemical Efficiency of a Potato Gun,” Project 2 Formal Report, ME 4731, Department of Mechanical Engineering, Mississippi State University, March 2, 2001.

“Determining the Effects of the Barrel Length and the Amount of Fuel on the Chemical Efficiency of a Potato Gun,” Project 3 Formal Report, ME 4731, Department of Mechanical Engineering, Mississippi State University, April 17, 2001.

STEPHEN T. MCCLAIN

Stephen T. McClain is a Lecturer and Undergraduate Laboratory Manager in the Department of Mechanical Engineering at Mississippi State University. He received his B.S. in Mechanical Engineering from The University of Memphis in 1995, and he received his M.S. in Mechanical Engineering from Mississippi State University in 1997. He is a part-time doctoral student and hopes to finish his degree in May of 2002.