

AC 2008-526: LEARNING STATICS BY STUDYING WORKED EXAMPLES

Mark Rossow, Southern Illinois University-Edwardsville

Mark P. Rossow is Professor of Civil Engineering at Southern Illinois University Edwardsville. He received the B.S. (1964) in mathematics engineering, and M.S. (1966) and Ph.D. (1973) degrees in applied mechanics from the University of Michigan. From 1973 to 1979, he was on the faculty of Washington University in St. Louis. In 1979, he joined the faculty of Southern Illinois University Edwardsville. His research interests lie in applying computers to problems in fields such as engineering education, solid mechanics, soil mechanics, surveying, reactor safety analysis, and structural optimization. He has consulted for the U.S. Army Corps of Engineers, Wimpey Offshore Ltd., and Argonne National Laboratory.

Address: Department of Civil Engineering, Southern Illinois University Edwardsville, Edwardsville, IL 62026; telephone: 618-650-2815; e-mail: mrossow@siue.edu.

Learning Statics by Studying Worked Examples

Introduction

The traditional way to learn in a problem-solving course such as statics is to solve a large number of homework problems. This approach is often inefficient and frustrating because students spend so much time *searching* for the solution that little time is left for *learning the principles* that will enable them to solve other related problems. Research in cognitive science has shown that under certain conditions, *studying worked examples* is a better way to learn than solving problems¹⁻⁹. The purpose of the present paper is to bring this work to the attention of a wider audience and to report on the writer's experience in implementing worked examples in a course in statics. Because the writer's approach is based strongly on a particular subfield of cognitive science called "cognitive load theory" (CLT), the paper will begin with an outline of CLT drawn from publications by several researchers closely identified with the theory^{2,5,8}.

Outline of cognitive load theory

1. CLT is derived from information-processing models of cognitive architecture. A number of such models have been proposed, some quite elaborate¹⁰⁻¹². Almost all contain at least two key elements that CLT treats as fundamental to the ability to learn: working memory and long-term memory. Working memory is what we are conscious of; it consists not only of a place for temporary storage of information but also an executive system that processes information. Long-term memory is stored information that we are not conscious of but that we can retrieve and move to working memory when the need arises.
2. A fundamental finding of cognitive science—and crucial for the worked example approach—is that working memory is very limited. The number of "chunks" of information that working memory can contain is, as expressed in the title of a widely cited article, "The magical number seven plus or minus two"¹³.
3. Long-term memory, on the other hand, appears to be essentially unlimited. Learning "may be defined as the encoding (storage) of knowledge and/or skills into long term memory in such a way that the knowledge and skills may be recalled and applied at a later time on demand"².
4. One key concept in CLT is "schema" acquisition. A schema is an element of long-term memory that a) although it may refer to multiple pieces of data, may be brought into working memory and treated as a single "chunk" of information, and b) contains information about how the data will be used. A chess master seeing a particular configuration of chess pieces on a board will recall the appropriate schema from long-term memory that will match the configuration on the board and will inform the master which are the best moves¹⁴⁻¹⁵. Upon seeing a textbook problem in electrical circuits, an experienced physics teacher recalls the schema that both categorizes the problem and informs the teacher what principles of circuit analysis to use. The very word "schema"

shares linguistics roots with “schematic”, and indeed a schema may be thought of as a schematic drawing of some process or relation stored in long-term memory.

5. Another key aspect of learning is “automation of schemas,” by which is meant the ability to recall and apply the appropriate schema easily with little concentration. In a chess exhibition, a chess master is able to play multiple games simultaneously by pausing at each board, recalling the appropriate schema, and then applying the associated move easily and quickly because the schema has been automated. The novice player, on the other hand, must exert considerable concentration in considering many possible moves and choosing the best one; the novice is *constructing*, rather than recalling a schema, and the process is far from automatic.

6. A schema can be acquired only if information is first recognized and processed in working memory. But because working memory is limited, schema acquisition and automation will be inhibited or will not occur if the capacity of the learner’s working memory is exceeded, that is, if the “cognitive load” is too great.

7. Technical subjects such as engineering often are intrinsically difficult and impose an intrinsic cognitive load on the learner. In contrast, *extraneous* cognitive load, that is, cognitive load resulting from activities that are extraneous to schema acquisition is avoidable and should be minimized through proper design of instructional materials—such as, for example, worked examples.

8. Novices attempting to learn by practicing problem solving experience a heavy extraneous cognitive load because they are engaged in a *goal-attainment activity* rather than a *learning* activity. The goal-attainment activity consists of searching for ways to reduce differences between the goal state (knowing the answer), sub goals (intermediate steps that will lead to the goal state), and the data given in the original problem statement. This procedure has been labeled “means-end analysis” and is widely employed by persons who are not familiar with the specific type of problem being solved¹⁶⁻¹⁷. That is, persons who do not possess well-developed schemas for a particular type of problem resort to means-end analysis as a general-purpose problem-solving strategy. Unfortunately, while means-end analysis may lead to solving the problem, it interferes with learning because working-memory capacity is devoted to *searching* for ways to obtain a goal or perhaps sub-goals leading to the final goal, rather than being devoted to formulating principles, identifying common characteristics, and generalizing approaches—in short, acquiring and automating schema. If learning happens to occur in the process, it is only as an incidental side effect. Indeed, experiments have been reported wherein subjects repeatedly used means-ends analysis to solve problems of an identical kind yet completely failed to learn from the activity¹⁸. That is, they were unable to discover the underlying principle that was common to all the problems and that allowed the problems to be solved much more simply and rapidly.

9. Under the right conditions, learning by *studying worked examples* is superior to learning by practicing problem-solving because the former imposes less cognitive load on the learner than the latter. Thus more working memory resources are available for

schema acquisition and automation. Obviously students have learned in the past and continue to learn by solving problems, but much of that learning may well take place during review and contemplation of the solution, once it has been obtained¹⁹. The efficiency of the process could be considerably improved by simply giving students the solution in the first place: at a minimum, the students are not distracted by having to locate trivial mistakes such as miscopying problems from the textbook or making an error with their calculators, but more importantly they do not waste working memory resources on searching.

10. Worked examples involving a combination of text and graphics may produce a cognitive load similar in magnitude to that produced by solving problems—that is, worked examples may *not* lead to improved learning—if the text and graphics are physically separated on the page (the “split-attention” effect) or if the text and graphics repeat the same material (the “redundancy” effect). Thus for effective schema acquisition and automation, 1) text and graphics in worked examples should be “physically integrated”, that is, text should be positioned as close as possible to related graphics, and 2) information should be presented only once, either in text or in graphics, but not in both. For many years, publishers of textbooks have implicitly recognized the validity of the split-attention effect by laying out the material in the book so that the reader need not turn the page to find a figure mentioned in the text, that is, the figure and the text referring to the figure are either on the same page or facing pages. CLT says that the publishers should go farther still and place text next to or actually on the figure.

11. The superior learning achieved by studying worked examples rather than by solving problems disappears as students become more proficient. Apparently, as learners develop expertise, the additional information contained in worked examples formatted to reduce cognitive load becomes *redundant* and thus interferes with learning²⁰⁻²². The existence of this “expert reversal effect” implies that the CLT worked-example approach applies to *novice* learners, that is, learners with no previous problem-solving experience in the field under study. The traditional work-problems approach is best once students begin to master the principles in their subject.

Observations on CLT and worked examples

Worked examples have of course been used in science and engineering education for many years, in lectures, in textbooks and in the familiar *Schaum's Outline Series*²⁴. Furthermore, students studying for a test will typically study worked examples—their own solutions to homework problems. So worked examples by themselves are nothing new. But one aspect of the *CLT approach* to worked examples is quite novel: the formatting of the examples to avoid the split attention effect and careful editing to avoid the redundancy effect. Fig. 1 shows a worked example in traditional form. The example is a typical problem in Coulomb friction such as would be found in a statics textbook. (Because of space limitations in this paper, only the first part of the example is shown). Note that the text describing both diagrams is separated from the diagrams themselves. Similarly the text describing the equations is separated from the equations. The reader must retain the meaning of the text in working memory while simultaneously searching

for the relevant part of the figure and the related equation. The reader's attention is split and extraneous cognitive load results.

Problem: Two uniform cylinders A and B each have a mass of 50 kg and radius of 300 mm. A horizontal force P is applied to the center of cylinder A. The coefficients of friction between the cylinders and the plane and each other are shown in the figure. Determine the largest value of P that can be applied without moving the cylinders up the inclined plane.

Solution: In the free-body diagram of cylinder A shown, the weight of the cylinder, $(50 \text{ kg})(9.81 \text{ m/s}^2) = 490.5 \text{ N}$, has been decomposed into components parallel and perpendicular to the plane, as has the force P.

The force P tends to move the cylinder up the plane. The friction force, f_A , from the plane opposes this motion. In addition, the component of P parallel to the plane tends to rotate the cylinder about the point of contact with the plane. The friction force, f_{AB} , opposes this rotation.

Taking into account the forces shown on the free-body diagram, we can write the equilibrium equations shown. Note that point O is a good point to choose for summing moments because only two forces appear in the equation.

$$\sum F_x = 0: N_{AB} + 207.29 - P \cos 25^\circ + f_A = 0$$

$$\sum F_y = 0: N_A - 444.54 - P \sin 25^\circ + f_{AB} = 0$$

$$\sum M_O = 0: (300)f_A - (300)f_{AB} = 0$$

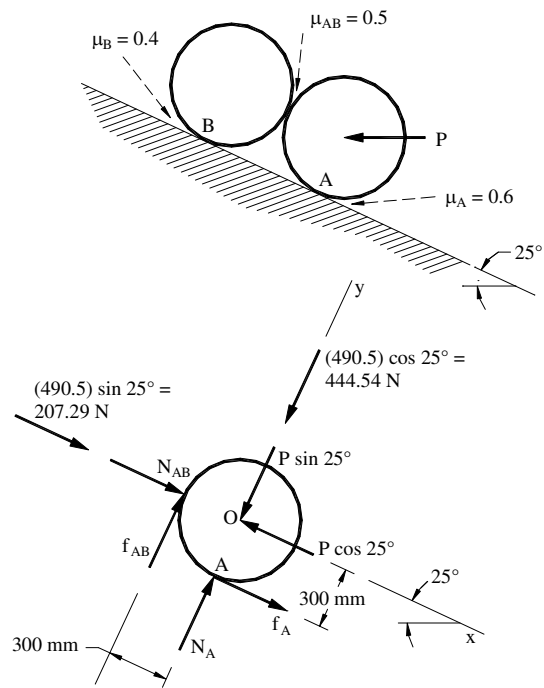

Fig. 1. Part of a typical friction problem presented in traditional format

Contrast this situation with that shown in Fig. 2, in which the same example has been reformatted according to CLT principles. Now the text and associated diagram or related equations are physically adjacent on the page. The reader's search effort has been reduced. Precious cognitive resources are not expended on searching but are instead available for schema acquisition and automation.

Problem: The horizontal force P is applied to the center of cylinder A. Determine the largest value of P that can be applied without moving the uniform cylinders up the inclined plane.

$mass_A = 50 \text{ kg} = mass_B$ (weight = $(50)(9.81) = 490.5 \text{ N}$)
 $radius_A = 300 \text{ mm} = radius_B$

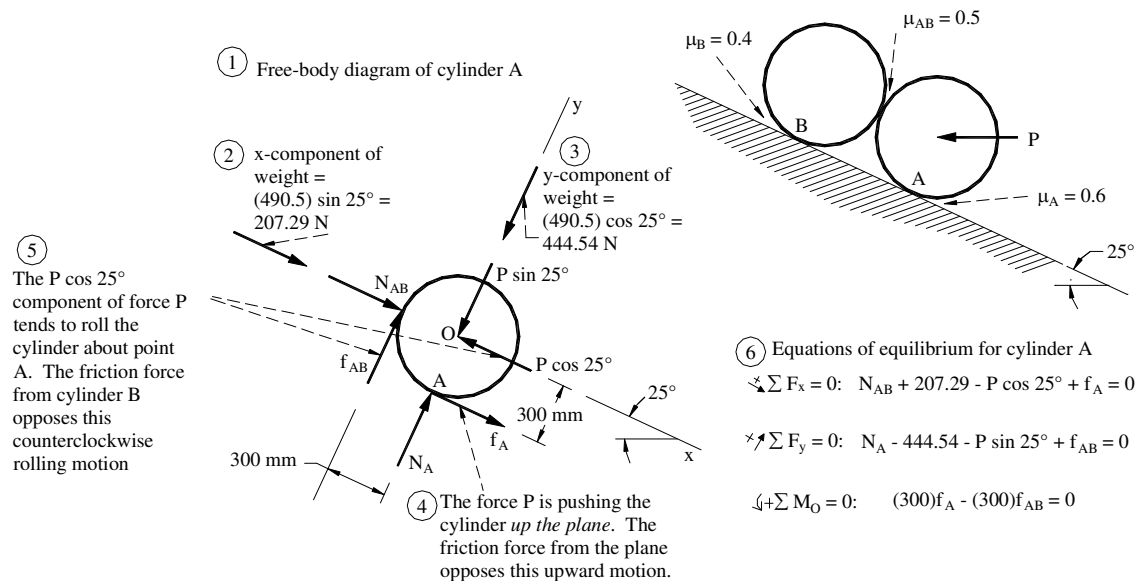

Fig. 2. Integration of text and graphics in CLT format

One other aspect of Fig. 2 calls for comment: it is cluttered. Clutter is typical of CLT worked examples. They offend one's aesthetic sense of how an example should appear in a textbook or on a computer screen; they violate conventional ideas about how examples should be formatted. However, the conventional format for presenting worked examples is derived from a) the convenience of the printer (who finds it easier to separate text and figures), b) the thought processes of the writer (who reduces his cognitive load by finishing one task—say, drawing the figure—before beginning another—writing the text), and c) tradition⁵. From the (crucial) viewpoint of improving student learning, there seems to be little theoretical support for organizing worked examples in the neat and tidy fashion seen in current textbooks.

What about redundancy in Figs 1 and 2? A moment's consideration of the figures shows that identifying redundancy is not quite as immediately clear-cut as one might at first expect. The difficulty is that what is redundant depends on the degree of expertise of the learner. Looking at Fig. 2, novice problem solvers most likely do not recognize that the weight has been decomposed into components. These students need a textual explanation of why the trigonometric factors are present. Experienced problem solvers, on the other

hand, do not need to be told—with text—that the weight of the cylinder in Fig. 2 has been decomposed into two components. These students know that immediately when seeing the trigonometric factors in the drawing. So the text is redundant for experienced students and should be omitted from the figure. For these students, much of the information in the worked example is redundant and thus imposes a higher cognitive load than is imposed by simply working the problems. This expert reversal effect, which has been described above, implies that students who are approaching the status of experts may actually make more progress by solving problems than by studying worked examples with detailed textual explanations.

Clearly, this aspect of redundancy being dependent on the expertise of the learner complicates the work of the designer of CLT-based instructional materials. One approach to this problem, when one is in doubt about whether or not material is redundant, is to make the conservative choice of including the possibly redundant material⁵. Skipping redundant material (as an experienced learner would do) provides less cognitive load than the search strategy that a novice would have to follow, if the explanatory material has been omitted.

An obstacle to learning by studying worked examples

For worked examples to be used effectively in learning, it is not sufficient that the examples be formatted according to CLT principles. A problem, well-recognized in the literature on using worked examples, is that of getting students to *study examples carefully*. Most students will read examples rapidly and superficially without pausing to draw conclusions or to extract general principles that can be applied in other problem contexts. What is worse is that students may experience the “illusion of understanding”²⁴, wherein they think that they understand the principles behind an example but in fact do not. To the extent that “learners’ mental effort largely influences the learning outcomes”²⁵, a means must be provided to ensure that students extract the ideas behind the example and make them their own—that is, construct schemas and automate them. Requiring students to solve problems has the undeniable advantage of ensuring that at least some mental effort must be expended; otherwise no answer will be produced. In addition, solving a problem and producing an answer provides *feedback* to students about the effectiveness of their learning activities, one of Gagne’s nine “events of instruction”²⁶ and a concept mentioned in the important book *How People Learn: Brain, Mind, Experience, and School*²⁷. A way is needed to ensure that mental effort is expended and feedback is gained while studying worked examples.

Researchers have proposed a number of ideas to get students to study examples deeply: **1. Paired problems**^{2,5}. Students are first asked to study a worked example and are then given a similar problem to solve on their own. Students must study the worked example carefully to be able to solve the paired problem. One difficulty with this approach, which became apparent to the author in the classroom application of this approach, is that considerable care must be taken in designing the problem to be solved. On the one hand, if the problem resembles the worked example too closely, students may employ mindless “pattern-matching” that enables them to calculate an answer without understanding any

of the underlying principles (no schema acquisition). On the other hand, if the problem does not resemble the worked example sufficiently closely, then the situation reverts to attempting to learn by solving problems—with the attendant waste of limited cognitive resources in a means-ends search.

Mention should also be made of the approach of Doering and Mu²⁸⁻²⁹, in which a “repository of solved circuit analysis example problems delivered as narrated video clips” is made available to students “by a website that facilitates searching for worked problems that are similar to the problems that have been assigned as homework.” Because the individual worked examples are not related to particular homework problems, Doering and Mu’s approach is not quite the same as the paired problem approach, but the idea of using homework problems resembling worked examples is similar.

2. Fading steps. A number of authors³⁰⁻³³, have suggested using “faded steps” in worked examples, that is, deliberately omitting a step from a worked example and then asking the student to supply the missing step. The idea is to make the transition from worked example to problem solving less abrupt—*less cognitive load* on the learner facilitates schema construction. Initially only one step is omitted. Then, as the student gains experience, more and more steps are omitted until the student has made the transition to solving problems without any guidance from a worked example. In an application to teaching electric circuits, Reisslein et al.³⁴ have studied the effects of the pace at which steps should be removed as a function of students’ prior knowledge of the subject matter, and have also considered the effect of “adaptive fading”³⁵ wherein the steps to be faded depend on the student’s success in supplying missing steps in examples already studied. The most striking illustration of the successful use of worked examples combined with step fading is one in which students learned algebra exclusively by studying worked examples with faded steps—no lectures, no textbook—and completed an entire three-year course in two years and scored slightly better than students following the traditional approach over three years⁹. The outstanding success of this application of the worked example/faded step method may possibly be attributable to the fact that the subject of algebra is uniquely well suited to the method because general principles are easily deduced after studying relatively few examples.

3. Eliciting of self-explanations through prompting. In a widely cited paper¹⁹, Chi et al. reported on experiments where students were asked to “think out-loud” as they studied physics examples. The experimenters found that the more successful students made significantly more “self-explanations”—statements explaining to themselves the basis for what steps they were following—than less successful students. The idea of “eliciting self-explanations” during the study of worked examples has been used by other researchers^{4, 25, 28, 36-37}. Of particular interest for the writer’s work in statics worked examples is the CASCADE model of learning^{7,38}, in which learning is assumed to occur when a student encounters and resolves (“self-explains”) an impasse—defined as a) the student does not know what to do next, b) the student notices that he or she has made an error, or c) the student is uncertain about some aspect of the problem. The obvious difficulty with an approach based exclusively on studying CLT-based worked examples is that the examples are *designed to contain no impasses*, that is, the stimuli that would

provoke learning have been removed. At the other extreme, the traditional approach of relying exclusively on working homework problems often has so many or such difficult impasses that students resort to a means/ends search and have little mental capacity for reflection and formulation of generalizations and principles. It would appear that learning is best facilitated when impasses are carefully chosen in both design and number. Researchers have proposed inserting, in the worked example, prompts such as multiple-choice questions³⁰. The questions typically are conceptual rather than quantitative in nature and are designed to force students to reflect upon and generalize their ideas about the example being studied. It is interesting to note that such “concept-eliciting questions” play a key role in the work of Steif and colleagues³⁹⁻⁴⁰, even though their focus is on learning through problem solving rather than through studying worked examples. Indeed, learning through solving problems begins to resemble learning through worked examples, when many prompts are supplied to the problem solver and when the student studying an example must answer questions as he proceeds through the example.

Description of a prototype

To test the CLT/worked-example approach to teaching statics, the writer prepared a set of worked examples, constructed according to CLT principles, for a course in statics and posted them on the Internet

[<http://www.siue.edu/engineering/civilengineering/examples.shtml>]. A set of paired problems was also developed. Paired problems were used because they could be constructed with considerably less time and effort than fading-step and prompted worked examples. Students in the author’s 2007 fall-semester statics class (enrollment: 54) were assigned worked examples to study for each class session. The instructor used class time to lecture on the theory and to work other examples. Students had to supply numerical answers to the paired problems that corresponded to the assigned worked examples. The paired problems were accessible through the university’s course management system (Blackboard). At the end of the course, a rather difficult, 25-question multiple-choice final exam was administered. The same exam had been used one year previously when the course had been taught with the usual solve-homework-problem approach. An opinion survey was also administered to the students at the end of the course.

Results

1. For the students who had studied worked examples, the mean and median percentage scores on the final exam were 50.5 and 48, with a standard deviation score of 18.2. For the students who had solved homework problems the mean and median scores were 48.0 and 44, with a standard deviation score of 6.9. This statistical comparison is not rigorous because students were not assigned randomly to the two test-taking groups, the in-class activities were not identical for the two classes, and problems used for the worked examples differed from the problems assigned as homework in the earlier class. (In fact, devising a statistically valid experiment to measure the effect of alternative ways of teaching *an entire course* is a daunting task because of the difficulty of isolating or

- eliminating confounding influences affecting a large number of people over an extended period of time. Most of the worked-example experiments cited in the reference list at the end of this paper are laboratory experiments that involve only a small number of examples, typically fewer than ten. A notable exception is the two-year algebra course of Zhu and Simon⁹. However, even though the comparison of exam scores lacks rigor, the writer would have interpreted a gross disparity—say, a 20-point lower average score for the worked-examples approach—as an indication of a significant shortcoming of the approach.
2. The opinion survey provided useful information: a) A large majority (82%) of the students indicated that they tried to work the problems on Blackboard *before* studying the worked examples. The worked examples were a *last* rather than a first resort. b) Many students (78%) reported that they *sometimes* were able to supply the correct answer to Blackboard even though they did not “really understand” what they were doing and instead merely followed the pattern of the worked example. Clearly many of the paired problems were too similar to the worked examples. c) Many students (86%) reported that they attempted individual Blackboard problems multiple times (Blackboard was set up to allow an unlimited number of attempts). Further questioning of the students revealed that their errors were usually attributable to trivial calculation blunders rather than a failure of conceptual understanding. Students were strongly in favor of allowing unlimited attempts because of the discouraging effect of receiving no credit after working hard on a problem but making a trivial calculation error. The author believes that researchers in educational problem-solving should pay more attention to eliminating students’ calculation errors. Such errors can seriously interfere with learning—students get a wrong answer but cannot determine if they have made a mistake in calculation or a mistake in the fundamental conception of the problem. A possible remedy is to train beginning engineering students thoroughly and correctly in how to use calculation programs such as MathCAD, Mat Lab, Mathematica, etc. Instructors often assume that students can learn these programs by themselves but in fact guidance is needed if calculation errors are to be minimized⁴¹. d) Ninety percent of the students preferred the worked example approach to the solve-problems approach. It is of course encouraging that students liked worked examples but merely liking them does not mean that the students learned more, especially in view of the “illusion of understanding” phenomenon associated with worked examples.

Future work

The results from the prototype worked-example statics course were useful but certainly show that there is much room for improvement. The most important problems that have been identified are the difficulty in designing example/problem pairs that are sufficiently close to prevent excessive cognitive load but sufficiently different to force careful study of the example, and the difficulty in getting the students to study the examples deeply. It appears possible to address both of these difficulties: 1) The introduction of faded steps (without a paired problem) would eliminate the tendency of students to attempt to solve the problem *before* studying the example and 2) Introducing multiple-choice prompting

questions would appear to be a means of disrupting pattern-matching as a solution approach and also would stimulate more self-explanations. In addition, using a two-monitor computer system, with one monitor displaying an example (with faded steps) and the other monitor displaying the worksheet of, say, MathCAD might be a way of reducing the calculation blunders that so frequently prevent students from determining whether a wrong answer is caused by ignorance of fundamental principles or merely calculation error. Implementing all these ideas in a computer-based learning environment that would permit automatic grading and variable rates of transition (through prompts and fading steps) would be a natural (and ambitious) extension of the work described above.

Acknowledgments

The support of the Excellence in Education program of Southern Illinois University Edwardsville is gratefully acknowledged.

Bibliography

- [1] Atkinson, R.K., Derry, S.H., Renkl, A., & Wrotham, D. (2000). Learning from examples: Instructional principles from the worked examples research. *Review of Educational Research*, 70(2), 181-214.
- [2] Cooper, G., (1998). Research into Cognitive Load Theory and Instructional Design at UNSW, http://education.arts.unsw.edu.au/CLT_NET_Aug_97.HTML (accessed 8 May 2004)
- [3] Kirschner, P. A. (2002). "Cognitive load theory: implications of cognitive load theory on the design of learning." *Learning and Instruction*, 12, 1-10.
- [4] Renkl, A. (2002). "Learning from Worked-Out Examples: Instructional Explanations Supplement Self-Explanations," *Learning and Instruction*, 12(5), 529-556.
- [5] Sweller, J. (1999). *Instructional design in technical areas*. ACER, Victoria, Australia.
- [6] VanLehn, K. (1998). "Analogy events: How examples are used during problem solving," *Cognitive Science*, 22, 347-388.
- [7] VanLehn, K. (1999). "Rule-learning events in the acquisition of a complex skill: An evaluation of CASCADE," *The Journal of the Learning Sciences*, 8, 71-125.
- [8] Van Merriënboer, J.J.G., Kirschner, P., and Kester, L. (2003). "Taking the load off a learner's mind: Instructional design for complex learning," *Education Psychologist*. 38, 5-13.
- [9] Zhu, X., and Simon, H.A. (1987). "Learning mathematics by examples and doing." *Cognition and Instruction*, 4, 137-166.
- [10] Anderson, J.R, et al (2004). "ACT-R Homepage." <http://act-r.psy.cmu.edu/about/> (accessed 8 May 2004)
- [11] Baddeley, A.D. (2003). "Working memory: looking back and looking forward." *Nature Reviews Neuroscience* 4, 829 -839.
- [12] Soar (2004). "Soar Homepage." <http://sitemaker.umich.edu/soar/>(accessed 6 Jan. 2008)
- [13] Miller, G. A. (1956). The magical number seven plus or minus two: Some limits on our capacity for processing information. *Psychological Review*, 63, 81-97.
- [14] Chase, W. G., and Simon, H.A. (1973). Perception in chess. *Cognitive Psychology*, 4, 55-81.
- [15] De Groot, A. D. (1966). "Perception and memory versus thought: Some old ideas and recent findings." *Problem Solving*, B. Kleinmuntz eds., Wiley, New York, NY, 19-50.
- [16] Larkin, H., McDermott, J., Simon, D., and Simon, H. (1980). "Models of competence in solving physics problems." *Cognitive Science*, 11, 65-99.
- [17] Simon, D. P., and Simon, H. A. (1978). "Individual differences in solving physics problems", *Children's thinking: What develops?* R.S. Stigler, ed., Hillsdale, NJ, Lawrence Erlbaum Associates.
- [18] Sweller, J., and Levine, M. (1982). "Effects of sub-goal density on means-ends analysis and learning."

Journal of Experimental Psychology: Human Learning and Memory, 8, 463-474.

- [19] Chi, M., Bassok, M., Lewis, M., Reimann, P. and Glaser, R. (1989). "Self-explanations: How students study and use examples in problem solving." *Cognitive Science*, 13, 145-182.
- [20] Kalyuga, S., Chandler, P., Tuovinen, J. Sweller, J. 2001. "When problem solving is superior to studying worked examples." *Journal of Educational Psychology*, 93, 579-588.
- [21] Kalyuga, S., Ayres, P., Chandler, P., & Sweller, J. (2003). "The expertise reversal effect," *Educational Psychologist*, 38(1), 23-31.
- [22] Reisslein, J., Atkinson, R.K., Seeling, P., and Reisslein, M. (2006). "Encountering the Expertise Reversal Effect with a Computer-Based Environment on Electrical Circuit Analysis." *Learning and Instruction*, 16(2), 92-103, April.
- [23] Shelley, J. F., (1990). *800 Solved problems in vector mechanics for engineers statics*. Schaum's solved problems series, McGraw-Hill, New York, NY.
- [24] Bannert, M. (2002). "Commentary. Managing cognitive load—recent trends in cognitive load theory." *Learning and Instruction* 12, 139-146.
- [25] Stark, R., Mandl, H., Gruber, H., and Renkl, A. (2002). "Conditions and effects of example elaboration." *Learning and Instruction* 12, 39-60.
- [26] Gagne, R., Briggs, L. and Wager, W. (1992). *Principles of Instructional Design* (4th Ed.). HBJ College Publishers, Fort Worth, TX.
- [27] Committee on Developments in the Science of Learning, (2000). *How People Learn: Brain, Mind, Experience, and School* (Expanded Edition available online). The National Academies Press <http://www.nap.edu> (accessed 29 Dec. 2007)
- [28] Doering, E. and Mu, X. (2007). "Circuits learned by example online (CLEO)," *Proceedings of the Annual American Society of Engineering Education Annual Conference and Exposition*, Honolulu, HA, June, 2007.
- [29] Project CLEO homepage, <https://www.rose-hulman.edu/cleo/> (accessed 8 January 2008).
- [30] Atkinson, R.K., Renkl, A., & Merrill, M.M. (2003). Transition from studying examples to solving problems: Effects of self-explanation prompts and fading worked out steps. *Journal of Educational Psychology*, 95(4), 774-783.
- [31] Renkl, A., Atkinson, R. K., and Grosse, C.S. (2004). "How fading worked solution steps works: A cognitive load perspective." *Instructional Science*, 32, 59-82.
- [32] Renkl, A. and Atkinson, R. K. (2003). "Structuring the Transition From Example Study to Problem solving in Cognitive Skill Acquisition: A Cognitive Load Perspective," *Educational Psychologist*, 38(1), 15-223.
- [33] Renkl, A., Atkinson, R. K., Maier, U. H., and Staley, R. (2002). "From Example Study to Problem Solving: Smooth Transitions Help Learning" *The Journal of Experimental Education*, 70(4), 293-315.
- [34] Reisslein, J., Sullivan, H., and Reisslein, M. (2007). "Learner Achievement and Attitudes under Different Paces of Transitioning to Independent Problem Solving." *Journal of Engineering Education*, 96(1), 45-56.
- [35] Reisslein, J., Reisslein, M., and Seeling, P. (2006). "Comparing Static Fading with Adaptive Fading to Independent Problem Solving: The Impact on the Achievement and Attitudes of High School Students Learning Electrical Circuit Analysis." *Journal of Engineering Education*, 95(3), 217-226, July.
- [36] Crippen, K.J. and Earl, B. L., (2007) "The impact of web-based worked examples and self-explanation on performance," *Computers & Education*, 49(3), Nov.
- [37] Gerjets, P., Scheiter, K., Catrambone, R. (2006). "Can learning from molar and modular worked examples be enhanced by providing instructional explanations and prompting self-explanations?" *Learning and Instruction*, 16, 104-121.
- [38] VanLehn, K., Jones, R.M. and Chi, M.T. (1992). "A model of the self-explanation effect," *The Journal of the Learning Sciences*, 2, 1-59.
- [39] Steif, P. and Dollar, A., "An Interactive Web-Based Statics Course," *Proceedings of the Annual American Society of Engineering Education Annual Conference and Exposition*, Honolulu, HA, June, 2007.
- [40] Steif, P., LoBue, J., Fay, A., Kara, B. and Spencer, S. (2007). "Inducing Students to Contemplate Concept-Eliciting Questions and the Effect on Problem Solving Performance," *Proceedings of the Annual American Society of Engineering Education Annual Conference and Exposition*, Honolulu, HA, June, 2007.
- [41] Rossow, M. P., (2003). "Developing Students' Calculation Skills—A Defense of the Black-Box

Approach,” *Computers in Education Journal*, Vol. 8, No. 4, October – December, 2003, 68-77.