



Milestones as a Guide to Drafting Project to Improve the Application of Dimensioning Specifications

Prof. Leonardo A. Bueno, Embry-Riddle Aeronautical Univ., Daytona Beach

Assistant Professor in the Engineering Fundamental department, teaching all the courses offered by the department. His focus is on teaching and preparing students for the upper-level classes that follow in their educational experience.

Milestones as a Guide to Drafting Project to Improve the Application of Dimensioning Specifications

Abstract

Students in first-year engineering often face this issue: a lack in their ability to apply the appropriate dimensioning specifications to design problems. Students need this skill in order to properly, and effectively, describe engineering solutions. This paper describes an attempt to engage learners by involving them in a design exercise where they are required to provide a detailed solution to a problem of their choosing. Through a series of milestones, learners are guided to: develop a design, check for completion, and conduct a final revision of their dimensioned sketches. It is proposed that through structured guidance, detailed feedback, and allowing students to invest effort and time in generating a solution of their interest, it will improve their dimensioning skills. This will be demonstrated through better-applied dimensions to their design solutions.

Introduction

The introductory course of Graphical Communications at Embry-Riddle Aeronautical University provides the student with the basic principles to improve and develop their visualization skills, 3D computer modeling abilities, and engineering design graphics as preparation for their engineering degree. The foundation for these areas is provided by a structure that consists of: exercise repetition during class, lab time, and structured feedback of homework. The culmination of the course is a final project requiring the use of several topics to reinforce learned course concepts and to strengthen the ability to make design decisions.^{8,9}

Traditionally, the final project encompasses the basics of Graphical Communication by requiring a set of drawings for a predefined object, leaving the CAD modeling, graphics and view layout decisions up to the student. This structure highlighted a problem, a lack in the students' ability to correctly apply dimension specifications to open-ended designs.

This paper describes an approach to the final project in which first-year engineering students create their own models and corresponding drawing sets. This exercise leads to the correct application of dimensioning specifications to the drawing sets as measured by the higher scores in their capstone assignment.

Background

This research attempts to investigate the difficulty in the adaptation of open-ended design problems in the Graphical Communication Curriculum. This is done with the use of a personal design project in which all design decisions are left to the student. This encourages a higher

level of involvement and brings to the forefront the need to be accurate in the use of proper dimensioning. This is a reasonable assumption given that the student is now aware that they are trying to communicate their own idea and not attempting to replicate a problem provided by the instructor.

Initially, previous attempts at a student-chosen design were less successful. In practice, it was due to the scope of such projects; they were often too large for the time available during the semester, typically three weeks. In order to remedy this issue, the project format was restructured to span over a longer period of time, seven weeks, during the semester and to have increased instructor supervision of the student progress. Therefore, formative assessment milestones were built directly into the process. This would provide timely and appropriate instructor feedback and guidance during the early design stages and to the creation of the CAD models. If the student were to choose a problem that was too large or too simple, the issue could be resolved work starts. In addition, the formative quality of the feedback would allow the student to develop a solution properly addressing the requirements of their design.¹

With the milestone format, it is expected that first-year students would be able to apply dimensioning with a greater degree of accuracy, as they would now possess detailed knowledge of the product and its complexities. That deeper understanding is necessary to apply critical to find the appropriate solutions in any skill-based learning situation.²

Approach

Milestones were initially used as a guide for the final project in the Summer 2013. The four milestones were:

1. Proposal of the product to be designed, to include a small set of hand drawings and description of the anticipated size and configuration. A minimum of eight individual parts were required.
2. Presentation of detailed dimensions for each individual part. Hand sketches of the configuration including final sizing of each part with particular emphasis on mating dimensions.
3. Complete 3D CAD models of parts and assembly.
4. Final set of dimensioned drawings. Specifically:
 - a. Isometric of assembly
 - b. Orthographic of assembly
 - c. Exploded view of assembly
 - d. Parts list
 - e. Dimensioned views of each par

While the course content was the same, it should be mentioned that the semester length and profile of the students is slightly different than during the fall or spring terms. The summer term is six weeks long, and students meet 4 times a week. While shorter than the regular 14 weeks, it permitted the student daily access to the instructor and to focus on a narrower academic workload.

As far as the students' profile during the summer term, they were not all first-year freshmen.

Twenty-four (of the 34 students) were high schools juniors enrolled in Embry-Riddle ESPER (Engineering Scholars Program at Embry-Riddle) prior to their senior year. ESPER students receive six semester hours that count as standard university credits and toward their high school GPA. Regular incoming freshman are high school graduates who either have declared an Aerospace Engineering degree or are enrolled as still exploring.

While there were differences in the academic status of the students, there is no significant difference in the profile of the students. The rising seniors are only one year away from attending college and being of similar age, they showed similar level of maturity. Also, they are academically minded students who were recommended by their corresponding high-school counselors and who are aware that they are enrolled in courses of higher education.

Compared to the anecdotal experience from previous semesters, the results were encouraging. 34 students formed 13 teams and all teams were able to create and complete all parts, assemblies and drawings for their project. Final project grade was high with 46% scoring above 90% and zero failures. While there was a significant reduction in dimension application errors, it was not completely eliminated, with 8 of the final projects still exhibiting a noticeable number of missing dimensions.

Design

This paper presents the application of milestones as guide to the final project in order to improve the application of dimensioning specifications during the Fall 2013 semester. This term was 14 weeks long and the majority of the students were first-year, first-semester engineering students, the majority of which are in the Aerospace Engineering program.

As the purpose of these intermediate markers is to allow timely feedback, the original milestones were not changed. They provided timely feedback to facilitate continuous progress. However, in the summer term it was observed that a quality control check could be implemented to further improve student performance. For the Fall term a review day with self-evaluation of the final drawing set was introduced 10 days prior the final due date. This increased the milestones from four to five:

1. Proposal of the product being designed, to include a small set of hand drawings and description of the anticipated size and configuration. A minimum of eight individual parts were required.
2. Presentation of detailed dimensions of each individual part. Hand sketches of the configuration including final sizing of each part with particular emphasis on mating dimensions
3. Complete 3D CAD models of parts and assembly.
4. Self-evaluation of the final drawing set. The final rubric and a list of common errors were provided. In addition, the instructor and teaching assistants were able to consult individually if the students require it.
5. Final set of dimensioned drawings. Specifically:
 - a. Isometric of assembly
 - b. Orthographic of assembly

- c. Exploded view of assembly
- d. Parts list
- e. Dimensioned views of each part

The results for the Fall semester are summarized in the following section showing the results for all students.

Results

The assessment was done through a rubric, developed by the author and provided in Appendix A, with a specific scoring component for dimensioning. A description of each item in the rubric is included in the appendix.

This is the same rubric that was used during the summer semester and it allows for a baseline when comparing scores. The instructor also remained the same for both terms.

There were a total of 54 students that created 26 final projects. Several projects were developed by individuals and no group was comprised of more than three members. The distribution in size and scores are shown in Table 1.

Table 1. Final and dimensioning score distribution based on group size

Group Size	Number of Groups of a size	Dimensioning Score Average	Final Project Score Average
1	6	74	85
2	13	78	82
3	7	89	93

Performance was much better in groups of three members however the relationship between group size and individual learners' abilities was not studied.

Table 2 lists the dimensioning score and its relation to the project final letter grade. This is an area of interest since this correlation shows that, as a whole, the higher the dimensioning score, the higher the total project grade.

Table 2. Summary of results of dimensioning scores

Dimensioning score %	Project Letter Grade	Number of Groups
Above 90%	A(9) B(1)	10
Above 80%	A(2) B(3) C(1)	6
Above 70%	A(1) B(1)	2
Above 60%	B(2) C(2)	4
Above 50%	C(2) D(2)	4

The rubric from the summer term was the same as the one implemented in the fall, dimensioning score distribution can be compared and it is shown in Figure 1.

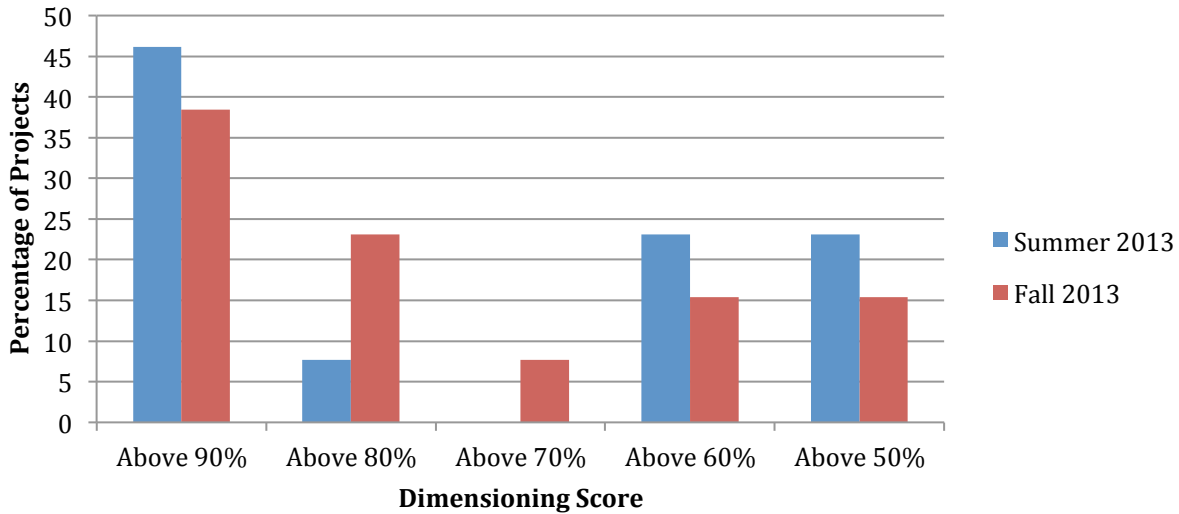

Figure 1. Dimensioning score vs. percentage of projects that achieved a particular grade

Figure 1 shows that the number of students with a passing grade in the dimensioning section improved significantly from summer to fall. The score was higher during the Fall 2013 semester at 70% scoring average or above versus 54% in the Summer 2013 semester for the dimensioning application score portion.

While the groups of students are very similar, external causes could have had an effect on the dimensioning scores. First, there is a slight difference in academic background as the rising seniors are still a year away from enrolling in higher education. However, they are highly motivated students who showed an interest in the sciences and engineering. A more likely cause for the difference is the actual time availability, with summer term students completing the project in 4 weeks as oppose to 8 weeks available to the Fall students.

The total final project grade did not follow the same pattern as the dimensioning score. In this instance, a few more projects did score a total that was lower than a B. This would not be totally unexpected given the increased in class size. The comparison between summer and fall is shown below in Figure 2.

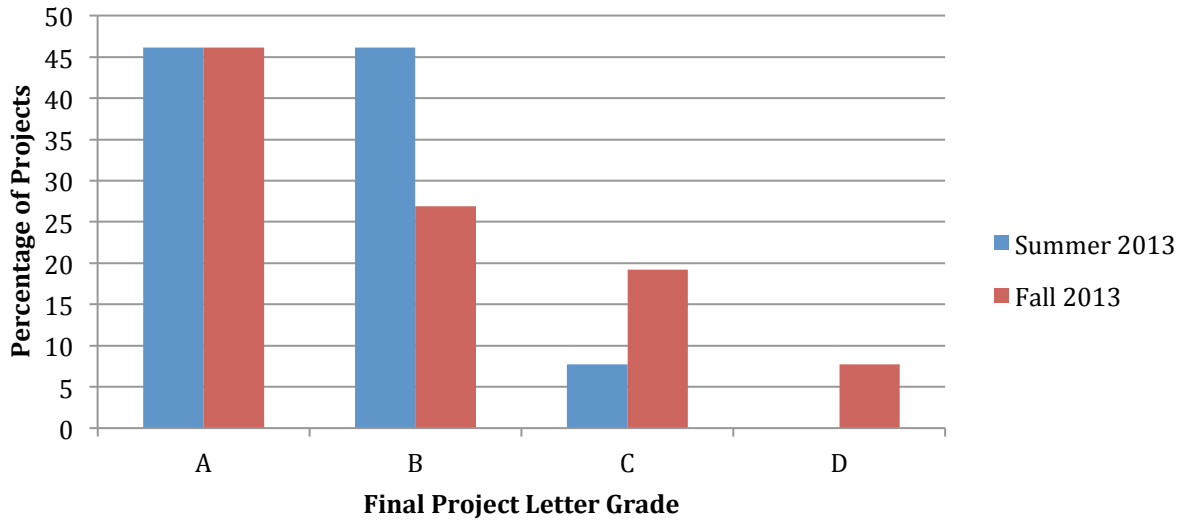

Figure 2. Final project grade vs. total projects that achieved that grade

As with the previous term, common errors were also recorded if they occurred in a project more than five times. The most common issues were grouped into categories: Missing Dimensioning, if a required dimension is not provided, Improper Dimension Location, if the dimension is located in the wrong place or view, and Incorrectly Displayed Units, if, for instance, feet were displayed instead of inches. Given the difference in class size, Table 3, lists the number of projects containing these errors as a percent of the total for the corresponding semester.

Table 2. List of most common errors

Type of Error	Percentage of Projects Containing the Error	
	Summer 2013	Fall 2013
Missing Dimensioning	62%	19%
Improper Dimension Location	46%	57%
Incorrect Displayed Units	46%	12%

There was a reduction in the cases with several missing dimensions however improper location still remains an issue across all projects.

The level of complexity in the final project varies, but students are free to choose a design that interests them. Figures 3 and 4 show sample extracts from a final project in which a student wanted to model a truck toolbox. Figure 3 shows how the parts were used in the assembly and one of the internal subassemblies built to support their design. In figure 4, the dimensioning for one of the parts of the subassembly is shown.

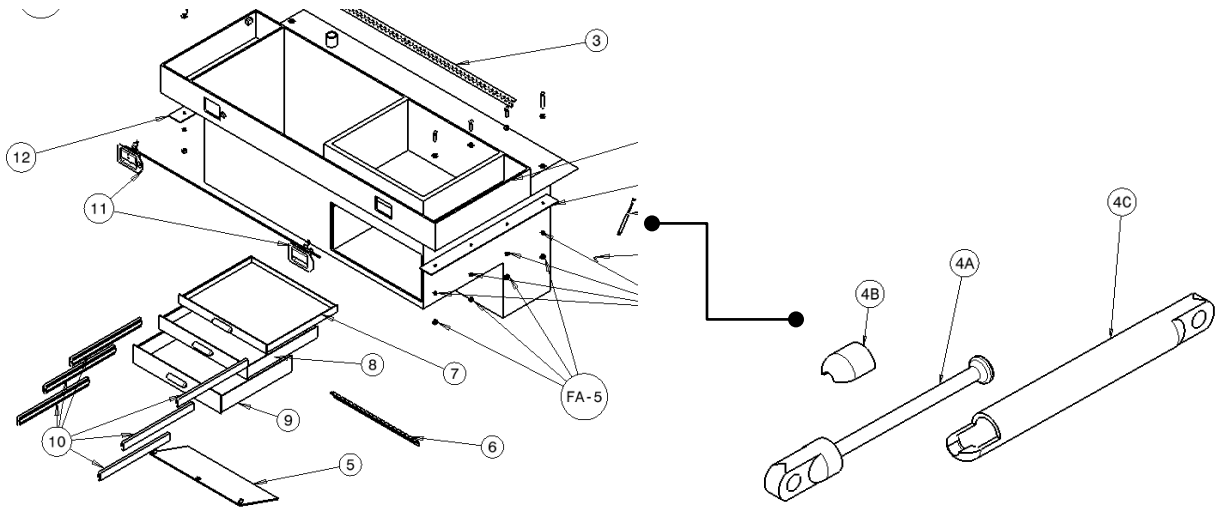

Figure 3. Portion of exploded view of final project product (left) and of internal subassembly (right)

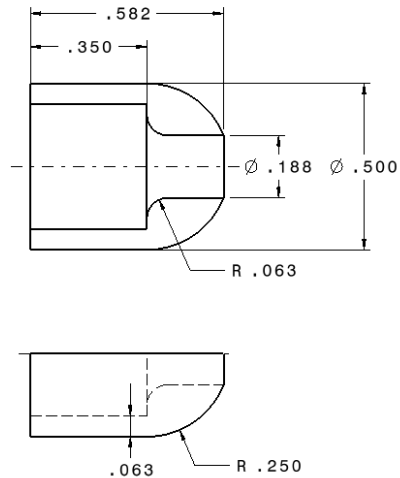

Figure 4. Dimensioned view of single element

Conclusions

The level of personal involvement of the students in their project appears to increase their commitment to complete the project in a professional and detailed manner. During both terms, most teams were able to complete projects with a grade of C or better.

Students do benefit from the internal knowledge of the complexities of their own project. They were able to complete with their projects, including all drawing sets in the time required. The addition of the quality control milestone provided a way of catching major mistakes or oversights prior to finishing the drawing set. This is shown as an improvement in the dimensioning application aspect of creating a drawing set. In this case, 70% of the class during the fall semester was able to achieve a grade of C or above as opposed to the summer term where only 54% did.

Given the benefits in student performance this format will continue to be used during the Spring 2014, the conditions and milestones will be kept the same as in the fall semester.

References

- [1] Leahy, K. (2012). Promoting best practice design intent in 3D CAD Modelling: Feedback as a constructivist paradigm of teaching and learning. *Department of Design and Manufacturing Technology. University of Limerick.*
- [2] Wright, D. (2007). The Decision Pattern: Capturing and Communicating Design Intent. *Computer Science Department North Carolina State University Raleigh, NC USA.*
- [3] Gerber D. and Forest F. (2011) Teaching Design Optioneering: A Method for Multidisciplinary Design Optimization. *CIFE Technical Report #TR203 June 2011. Stanford University.*
- [4] Rynne A. and Gaughran W. (2007) Cognitive Modelling Strategies for Optimum Design Intent in Parametric Design. *American Society for Engineering Education AC 2007-2132*
- [5] Tate, Derrick et al. (2010) Matching pedagogical intent with engineering design process models for precollege education. *Artificial Intelligence for Engineering Design, Analysis and Manufacturing (2010), 24, 379–395.*
- [6] Condoor, Sridhar et al (2008) The Art of Design Modeling – Teaching Freshmen. *American Society for Engineering Education AC 2008-2094*
- [7] McInnis, J., Sobin, A., Bertozzi, N., Planchard, M. (2010) Online Working Drawing Review and Assessment. *Engineering Design Graphic Journal, Vol. 74, No. 1*
- [8] Devine, K. (2012) Dimensional Tolerances: Back to Basics. *Engineering Design Graphic Journal, Vol. 76, No. 1*
- [9] Lamb, C. and Kurtanich, D. (2007) Drafting the Basics. *Engineering Design Graphic Journal, Vol. 71, No. 3*

Appendix A

Rubric for evaluation of final project:

FINAL PROJECT RUBRIC	
NAMES: _____	
ASSEMBLY:	_____ / 10
ELECTRONIC FILES:	_____ /5
ISO, ASSEMBLY:	_____ /5
ORTHO, ASSEMBLY:	_____ /10
EXPLODED:	_____ /10
PARTS LIST:	_____ /10
INDIVIDUAL PARTS:	
DIMENSIONING	_____ /30
VIEWS	_____ /10
PRESENTATION (TITLE BLOCK, PRINTING, NEATNESS)	_____ /10
TOTAL	_____ /100

What are the expectations of each segment in the rubric?:

- ASSEMBLY
 - o Individual parts constrained properly
 - o Interference issues?
- ELECTRONIC FILES
 - o Are all files' dependencies correct?
- ISO, ASSEMBLY
 - o Is the isometric view of the assembly correct?
 - o Are line type conventions correct?
- ORTHO, ASSEMBLY:
 - o Are the orthographic views of the assembly correct?
 - o Are line type conventions correct?
- EXPLODED:
 - o Is the exploded view shown correctly?
 - o Are all part labeled so that they match the parts' list?
- PARTS LIST:
 - o List the parts' names, quantity and number (to match exploded view)
- INDIVIDUAL PARTS: DIMENSIONING:
 - o Dimension missing?
 - o Dimension applied correctly?
- INDIVIDUAL PARTS: VIEWS:
 - o Are the views correct or sufficient?
- PRESENTATION:
 - o Overall presentation of the drawing set. Title block format, printing scale, page order, proper spelling.