

AC 2009-2082: RAPID PROTOTYPE TOOLING TO TEACH NET-SHAPED MANUFACTURING

Louis Reifschneider, Illinois State University

Lou Reifschneider is an Associate Professor in the Department of Technology at Illinois State University. He received his BSME in 1983 from the University of Notre Dame, his MSME in 1984 from the University of Minnesota, and his PhD ME in 1990 from the Ohio State University. Prior to joining ISU, Dr. Reifschneider worked in the field of computational engineering analysis software development focusing on plastics processing. His research interests include plastic product design, mold and die design, and the processing of bio-based materials. Since 1998 he has taught courses in manufacturing technology, product design, and engineering economics. He is a Registered Professional Engineer in Illinois and holds memberships in SPE and ASEE.

Rapid Prototype Tooling to Teach Net-Shaped Manufacturing

Abstract

Net-shaped manufacturing plays a central role in contemporary production because complex three-dimensional shapes can be created in a single step using a mold. Further, because of the time and special skills required to build molds, net-shaped manufacturing is a difficult process to teach first-hand in engineering design curriculums. However, the advent of lower cost rapid prototyping technology capable of making molds that can withstand the temperatures and pressures of thermoforming provides a means to teach net-shaped product design in semester-long courses. This paper provides examples of student projects that illustrate the level of design complexity possible with the paired use of prototyping and thermoforming. Finally, some of the costs associated with the prototyping and forming technologies are outlined to provide a measure of the resources required to implement this strategy in a design curriculum.

Why net-shaped processing matters

While many product design courses utilize rapid prototyping to communicate the form and fit of designs¹, the focus of this paper is to outline how rapid prototyping can better help students understand the design for manufacturing requirements of net-shaped manufacturing. Other authors advocate the need for education about rapid manufacturing in order for the US manufacturing base to remain competitive^{2,3}. Creese³ has shown how rapid prototyping leads to reduced time to create castings. In a similar way, rapid prototyping can reduce the time required to create molds used to teach students about the net-shaped manufacturing process. Net-shaped manufacturing and rapid manufacturing share one element in common: neither are subtractive processes like CNC machining. However, unlike rapid manufacturing, net-shaped manufacturing offers the economies of high production rates and low unit cost once the investment in a mold has been made.

In Figures 1 and 2 the subtractive process of CNC machining is compared to the casting process, a net-shaped manufacturing process, for the example of creating a simple container shape. Teaching students the thought process of mold design required for a net-shaped process is distinct from teaching conventional product design. For example, net-shaped manufacturing processes require the product to have draft to facilitate product removal from the mold, as shown in Figure 3. This is a unique requirement from that seen in a subtractive process.

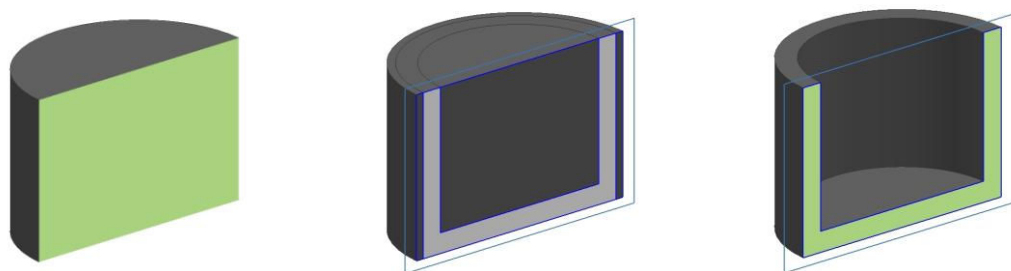

Blank

CNC material removal

Product

Figure 1 Section views of material removal in a machining process

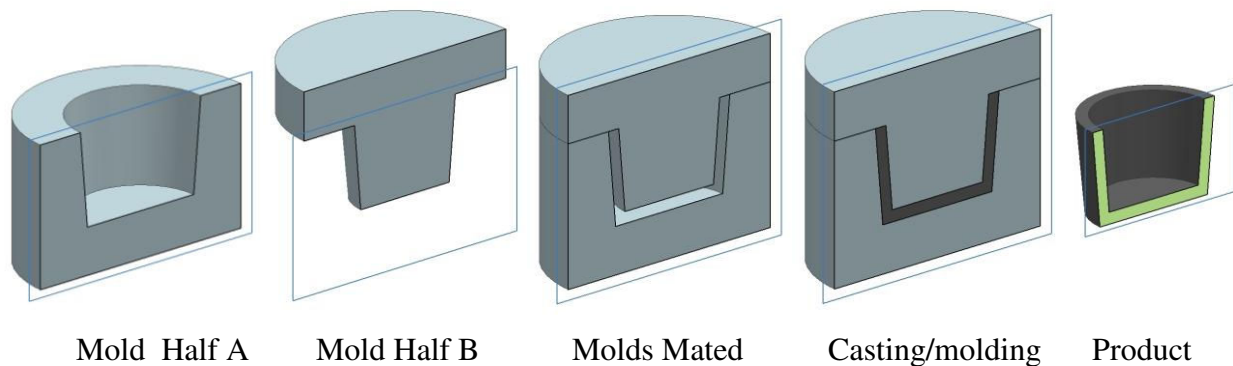
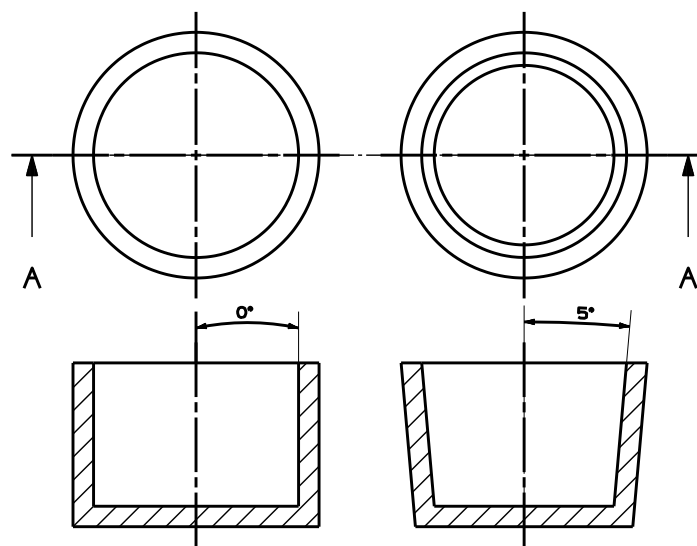

Figure 2 Section views of a net-shaped manufacturing process



SECTION A - A

Material removal process Net-shaped process

Figure 3 Net-shaped manufacturing requires draft for product release from mold

Thermoforming as an attractive net-shaped process platform for education

One of the hurdles faced by product design instructors is the limited time available for students to create the product they design. This is especially true for product design involving net-shaped manufacturing because the product is the result of a mold that must be made. Two widely used net-shaped processes are injection molding and thermoforming. Thermoforming provides the more attractive platform to develop designs and form products during the limited time of a typical design course, because injection molding requires two mold halves while thermoforming requires only one. Figure 4 illustrates the basic differences in the mold requirements for injection molding and thermoforming. Injection molding requires that a delivery system be designed in the mold, and, because there are two mold halves, an alignment system must be designed and fabricated. Further, the injection molding process involves high pressure and molten plastic. The pressures and temperatures involved limit the material that can be used to make prototype molds. Selective laser sintering is the only appropriate rapid prototyping method for rapid manufacture

of injection molds. Thermoforming, on the other hand, requires only atmospheric pressure, and process temperatures are below the melting temperature of plastic materials. Thus, a plastic mold can be made for prototype thermoforming. The other benefit of the thermoforming process is the fact that only a single mold component is required. The lack of mating mold halves simplifies the fabrication process considerably: no precision placement of locating pins. However, thermoforming molds do require the creation of vent holes and the construction of a plenum box to promote evacuation of air throughout the mold cavity. Yet, the single mold makes design for thermoforming more attractive for a semester design course. Instruction of the design rules for net-shaped parts via thermoforming can be introduced to students and then students can develop original designs to be made and tested in a matter of a few weeks. The advent of lower cost rapid prototyping technology such as the fused deposition modeling (FDM) process by Stratasys⁴ and the three-dimensional printing technology of the Z Corporation⁵ make it more economical to consider creating rapid prototyped molds.

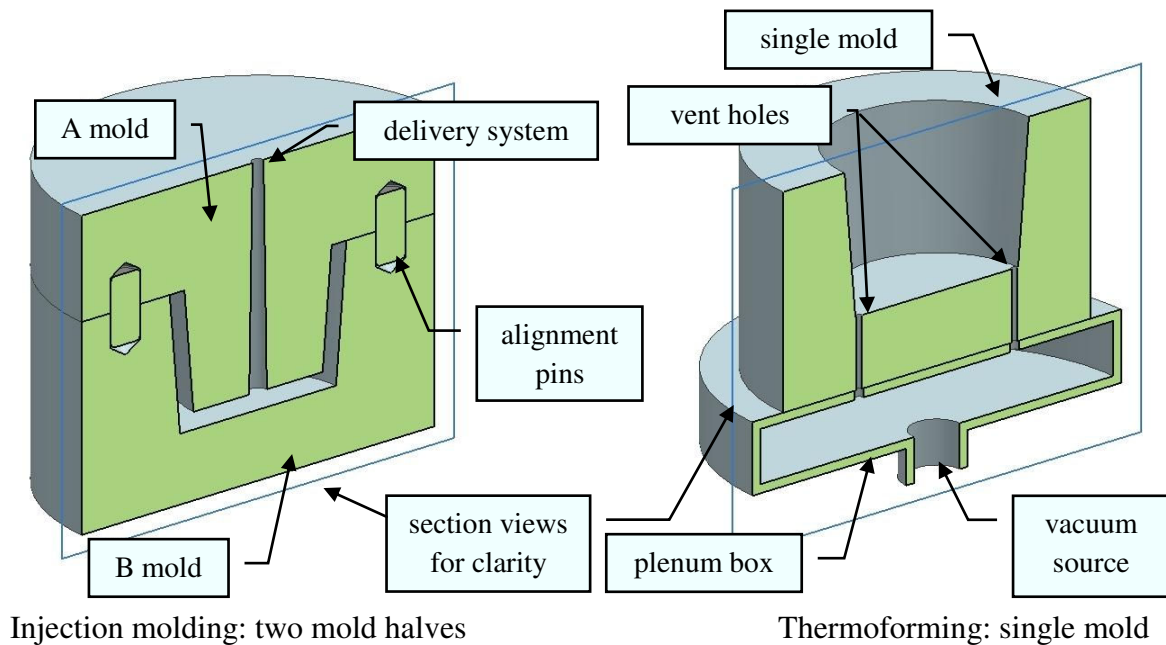

Figure 4 Alternative net-shaped manufacturing processes to make product

Alternative rapid prototyping platforms

Of the four common prototyping platforms available today¹, the FDM and the three-dimensional printing process offered by the Z Corporation, ZPrinter, are the most economical for an academic environment. They both have relatively inexpensive build materials compared to alternative processes and are both relatively easy to operate. The author prefers the FDM process over the three-dimensional printing of a gypsum-based material because the latter process requires a depowdering step to clean the prototype. Further, any residual powder on molds made from this process may become problematic for the vacuum systems used in thermoforming machines. The FDM prototypes do not require any such clean-up because they are made of fused thermoplastic. The ZPrinter platform does have the advantage of a faster build rate compared to the FDM process. However, there are build practices that can be used with the FDM process developed by Stratasys that greatly reduce the time and cost to build.

Economic FDM build practices

Two practical mold design requirements for thermoforming include the use of back drilled vent holes to promote the movement of air out of the cavity and some way to fasten the mold to the plenum box. These are illustrated in Figure 5. Fortunately, the FDM build process can easily accommodate these design features, so a complete, ready-to-use, mold can be prototyped. For example, if the taper angle of the hole creating the back drilled hole and mounting hole is 90 degrees, the machine will not place support material below the tapered surface. This build feature permits long narrow back drilled holes to be made free of any material inside the hole. Another factor important for economical creation of rapid prototype molds is the ability to create a mold that is not completely solid. The FDM process developed by Stratasys permits a three-dimensional model to be made without a solid filling of material in the interior. A skin of 0.040 inches is created at all surfaces and a sparse fill is created inside of this skin as shown in Figure 6. This build technique saves material cost to make a mold and permits a faster build time. Please refer to Table 1 in the section of the paper summarizing prototyping machine options for a comparison of costs to build a mold with solid vs. sparse fill.

The sparse fill results in a mold that is rigid enough to be used for vacuum forming. Further, the ABS plastic used to create the mold also resists delamination and melting even when being used to form 0.125 inches thick ABS plastic. It must be noted, that no cooling is placed in the plastic FDM molds. Therefore, aggressive top-side cooling must be applied after the sheet is formed to remove much of the energy from the sheet with air convection and not allow much thermal conduction into the plastic mold. In spite of this potential problem, the author has seen over 30 products made from an FDM mold while forming 0.125 inches ABS before the mold began to exhibit a delamination of the skin from the sparse fill support.

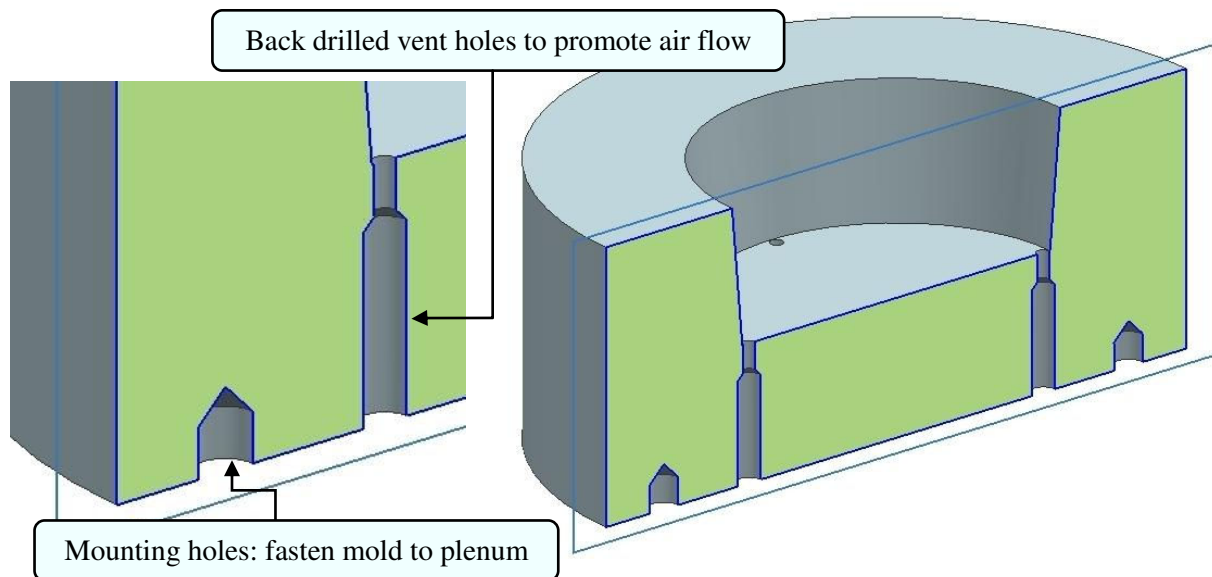
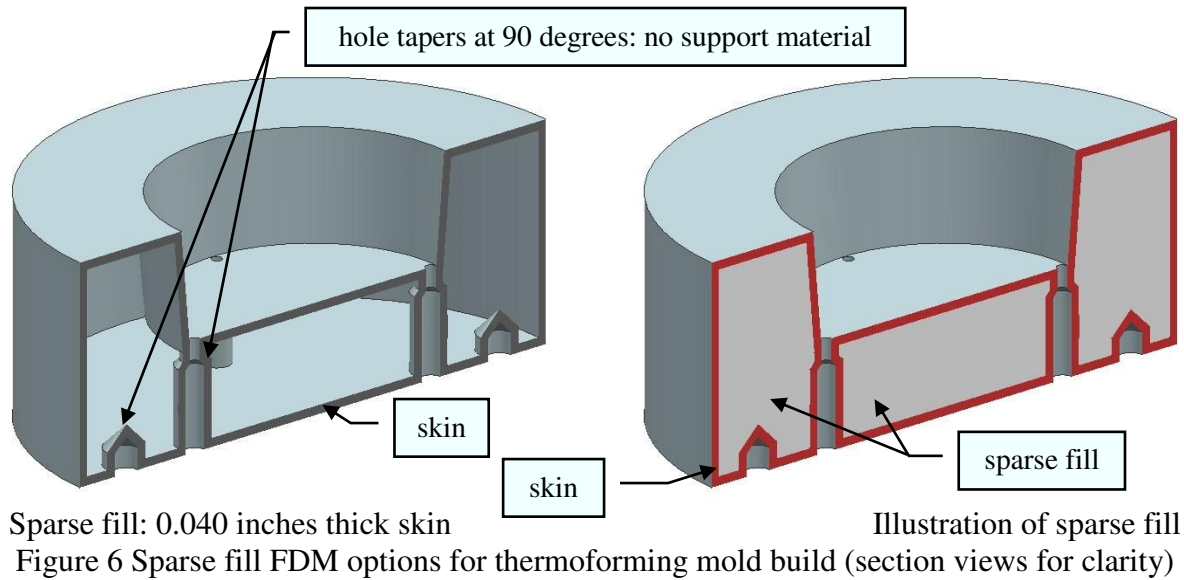

Figure 5 Practical thermoforming mold details (section views for clarity)



FDM builds ready-to-form mold

Another advantage of the FDM process is that all important mold features can be built in the prototype machine. Vent holes and mounting holes can be made that require no additional preparation, other than tapping a hole for a 1/4-20 screw in the case of the mounting holes. The machines can produce fine enough detail to create the 0.010 inches diameter vent holes required by a typical packaging mold. Figure 7 illustrates vent holes made during the build of a mold for a packaging tray that will be discussed in more detail in the next section.

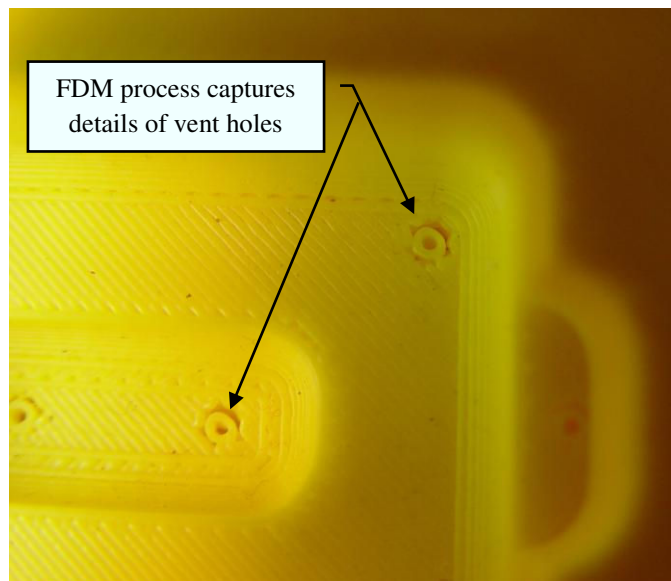

Figure 7 Complete mold details made during FDM build

Nontrivial design challenges with thermoformed products

There are numerous design possibilities with thermoformed products:

- Packaging of common consumer goods: pens, toys, tools.
- Material organizers: thermoformed dunnage trays are common in industry.
- Medical trays, sterile instruments delivered to the operating room in a custom-formed tray.
- Electronic packaging: for safe shipment and point of sale display.
- Food packaging: cookies, cakes, candies.
- Housing for equipment: medical imaging, electrical panels.

Two examples of student-developed products are presented to illustrate the level of complexity that can be addressed with design projects involving net-shaped manufacturing. One project involved making packaging for candy using thin gage plastic sheet and another employed heavier gage plastic to make a durable card game device. In addition to illustrating the benefits of the rapid mold fabrication with FDM, some of the limitations of utilizing FDM prototypes for thermoforming molds are addressed.

The packaging design problem solved by a student is illustrated with a photo of the rapid prototyping (FDM) mold in Figure 8. The requirements of the formed tray were to present several candies to the customer, promote the program hosting the event (hidden from view in this photo), allow for easy access to the candy, and provide a means to easily trim the formed sheets for placement in a box, as shown in Figure 9. The student achieved the design requirements with a set of finger pockets and registration features called out in Figure 8. The student also had to design for shrinkage of the formed material. The 2% shrinkage of the HDPE used to make the candy tray was a critical factor in placing the registration features so the final cooled tray could be trimmed to the correct size.

FDM patterns for casting

Another avenue of design that can be explored is the creation of castings from patterns made with the FDM process. The castings are used as molds to form thermoplastic parts. Creation of patterns to cast aluminum molds is a common practice in the thermoforming industry. The design complexity involves accounting for the shrinkage of the casting as well as the shrinkage of the formed part when determining the proper size of the pattern features. A student design project involving the creation of a card playing discard and pick-up tray is shown in Figure 10. The aluminum mold permitted relatively rapid forming cycles of heavy gage plastic because the mold is not imperiled by the heat absorbed by forming the hot plastic. The author has witnessed plastic FDM molds used for drape forming plastics breaking apart due to stresses caused by the thermal shrinkage of the formed plastic sheet upon the proud features of the mold. Note the six proud features of the card tray mold. It is likely that an ABS mold made via the FDM process would have failed while forming the first product. This is one shortcoming of using the FDM material for thermoforming molds that involve proud features. The ZPrinter technology, when made as a solid block, would provide a tougher molding platform.

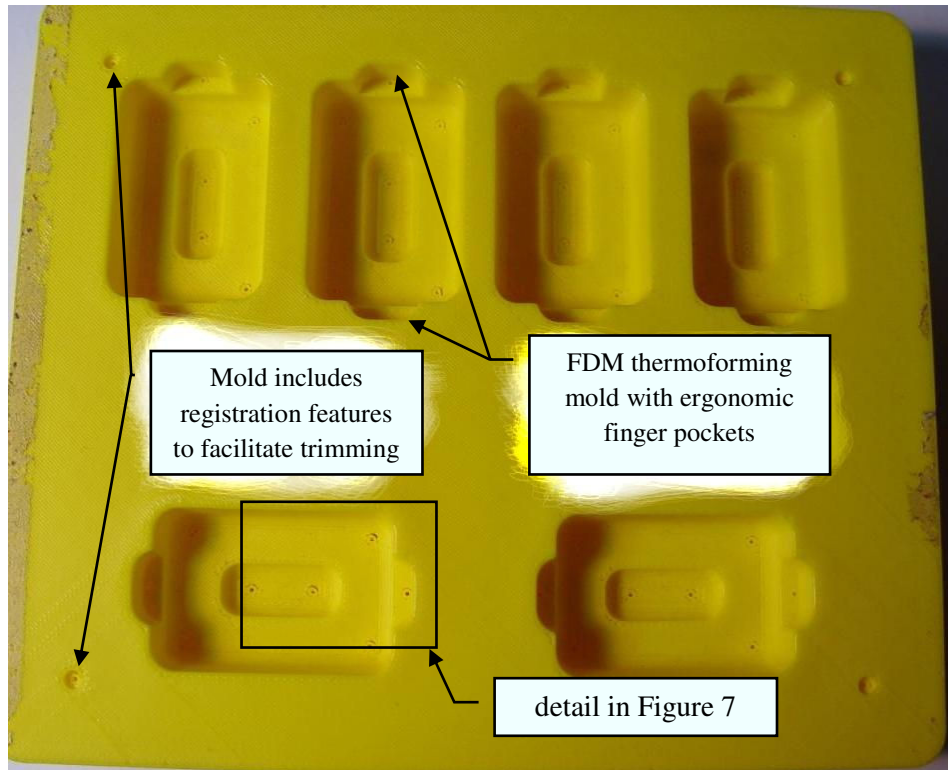

Figure 8 FDM thermoforming mold of student-designed packaging tray



Figure 9 Formed plastic candy tray, trimmed, and in use



Building FDM pattern



Pattern used to create casting



Ramming-up sand casting mold



Casting (mold) mounted on plenum box

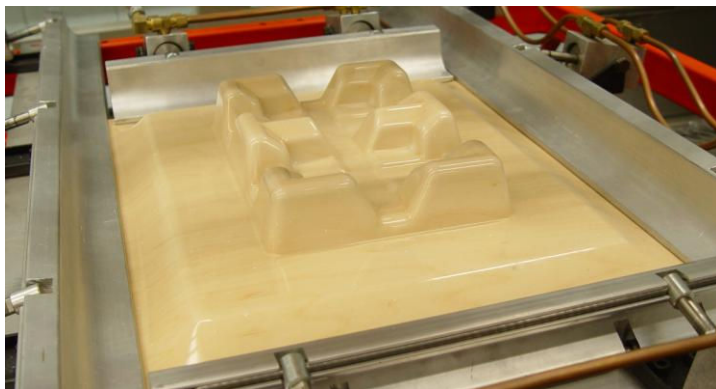

Sheet formed over mold
Figure 10 FDM used as pattern for cast aluminum thermoforming mold

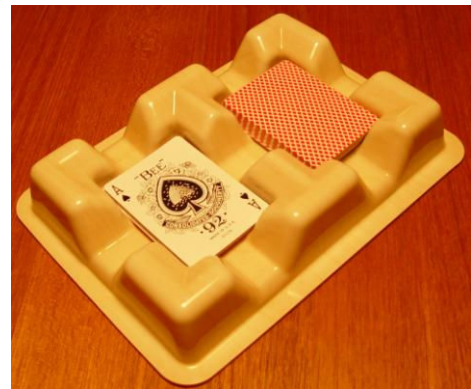

Trimmed product in use

Prototyping machine options

Although the initial investment in a rapid prototyping machine is significant, the machine can be used by several disciplines within an engineering technology program. For example, a common application of rapid prototypes is the creation of a single part or assembly of parts. The other important factor when considering rapid prototyping is the speed of build and the cost of the consumables to build. For the purpose of brevity, this paper will only address the popular prototyping technologies seen in academic settings: the Dimension BST printer and the Z

Corporation ZPrinter 310. The purchase prices of the platforms are comparable. The list price of a Dimension BST is \$18,900 and the list price of a ZPrinter 310 is \$19,900. The other factors that dictate how often a prototype will be made for a given design is the cost of the consumables and the time required to build a prototype. Table 1 illustrates the differences between these two platforms when building some of the molds described in this paper. The third example listed in Table 1 is the creation of a solid block that measures 8” wide by 8” long by 2” thick. This is a trivial shape, but it clearly illustrates the comparison of FDM solid fill, FDM sparse fill, and ZPrinter (gypsum). It should be noted that when vent holes are created in an FDM mold, it slows the time to build for a comparable volume of mold due to the slower traversing required to create the small hole details, as in Figure 7.

Product	Basic dimensions (L x W x height)	Notable Features of prototype	FDM Solid fill		FDM Sparse Fill		Zprinter 310	
			Build Time (hr)	Material Cost	Build Time (hr)	Material Cost	Build Time (hr)	Material Cost
Cup Mold	5" diam x 2" high	large cavity	19	\$ 153	6	\$ 31	2	\$ 78.00
Candy Tray	5.8 x 6.8 x .75	many small holes	20	\$ 117	14	\$ 43	1	\$ 59.00
Block	8 x 8 x 2	"solid" block	66	\$ 590	14	\$ 99	3	\$ 256.00

Build layer factors: FDM build layer 0.010 inches; ZPrinter build layer 0.005 inches at 2 layers/min.

Build material costs: FDM at \$4.50/cubic inch; Zprinter at \$2.00/cubic inch.

Table 1 Rapid prototype consumables for various mold designs

Forming machine options

The other capital investment needed to deploy net-shaped manufacturing in a design curriculum as outlined in this paper is the purchase of a thermoforming machine. A conventional thermoforming machine has a heat source to soften the plastic sheet and a movable platen that holds the mold. The mold is typically pushed into the softened sheet just prior to forming. Forming is achieved with atmospheric pressure pushing against the vacuum created below the mold surface. Vent holes created in the mold allow the air in a cavity space to be evacuated during forming. There are three levels of sophistication available in forming machines, each with a significant increase in cost. Table 2 summarizes the key differences in operation and cost for forming machines offered from representative vendors. A very simple bench-top unit is available for \$1,500, the Therm-O-Vac from Pitsco⁶. This unit does not have a movable platen but instead has a frame that holds the plastic as it is heated, and through a pivot action the softened sheet is pushed onto a stationary mold before vacuum is applied. Formech Inc.⁷ offers a similar small table-top unit, the Formech Compact-Mini, which has a movable lower platen and a movable oven, so the clamped sheet remains stationary. Formech sells larger versions of this manual, movable lower platen machine. With greater cost, one gets a larger forming area and more control of the heating profile imparted to the thermoplastic sheet. The machines offered by Formech, however, are all manually controlled machines. Zed Industries⁸ offers several platforms suitable for education. Their lowest level machine is a bench-top unit, the Model L, which has similar functionality to the Formech 450. The Zed Industries Model L2 is a fully functional thermoforming machine. It has pneumatically driven upper and lower platens with PLC control and zoned oven temperature control. This platform would allow all major types of thermoforming to be accomplished: vacuum, drape, plug-assist, and snap-back. A lower cost alternative to the Zed Model L is the MAAC ASP offered by MAAC Machinery⁹. If only the basics of net-shaped design are the goal of the design program, then the author would suggest a

Formech model 450 or the Zed Industries Model L. The under \$10,000 price provides enough functionality to demonstrate design challenges related to packaging. The Zed Industries Model L2 and the MAAC ASP are industry-type machines that offer the full breath of the thermoforming process for students.

Grant monies are available to universities seeking to implement the thermoforming process in their program. The Society of Plastics Engineers, through the Thermoforming Division¹⁰, provides a generous matching grant of up to \$10,000 to purchase thermoforming machinery.

Manufacturer/Model	Number of Platens	Power and Controls	Zoned Heat Control	Forming Area	Approx. Cost
Therm-O-Vac	none: swing frame	manual	no	15" x 20"	\$ 1,500
Formech Compact Mini	single lower	manual	no	9" x 11"	\$ 2,400
Formech 450	single lower	manual, heat timer	yes	17" x 17"	\$ 9,500
Formech 660	single lower	manual, heat timer	yes	24" x 24"	\$ 19,800
Zed Industries Model L	single lower	manual, heat timer	yes	14" x 15"	\$ 9,000
Zed Industries Model L2	upper & lower	pneumatic, PLC	yes	25" x 25"	\$ 50,000
MAAC ASP	upper & lower	pneumatic, PLC	yes	30" x 36"	\$ 35,000

Table 2 Thermoforming machine platform comparisons

Conclusion

It has been shown that combination of rapid prototyping technology and thermoforming make it possible to teach a one-semester product design course that includes a net-shaped manufacturing activity. Rapid prototyping technology permits a “design to formed part” experience that does not involve any CNC machining of a mold. Thermoforming is an attractive manufacturing platform because the tooling design is not overly complex and yet non-trivial design problems can be posed to students. For programs that already have prototyping technology, a thermoforming machine can be added for well under \$10,000. This investment will provide design students with first-hand experience of the important net-shaped product design process.

Bibliographic Information

- Rodriguez, J, Choudhury, A., Keil, M., Ramrattan, S., & Ikononov, P. (2006). Applications of Rapid Prototyping for Engineering Design Projects, Proceedings of the 2006 American Society for Engineering Education Annual Conference and Exposition.
- Czajkiewicz, Z., Sirinterlikci, A., & Usla, O. (2007) Rapid Manufacturing – The Future of Production Systems, Proceedings of the 2007 American Society for Engineering Education Annual Conference and Exposition.
- Creese, R. (2007) Rapid Manufacturing via Metal Casting, Proceedings of the 2007 American Society for Engineering Education Annual Conference and Exposition.
- Stratasy, Inc., Eden Prairie, MN <http://www.stratasy.com>
- Z Corporation, Burlington, MA <http://www.zcorp.com>
- Pitsco, Pittsburg, KS <http://pitsco.com>
- Formech Inc., Chicago, IL <http://www.formech.com>
- Zed Industries, Vandalia, OH <http://www.zedindustries.com>
- MAAC Machinery, Carol Stream, IL <http://www.maacmachinery.com>
- Society of Plastics Engineers, Thermoforming Division <http://www.thermoformingdivision.com>