

Scaling Analysis – A Valuable Technique In Engineering Teaching And Practice

Eugene M. Kopaygorodsky, William B. Krantz, Vadim V. Gulians
University of Cincinnati

Abstract

This paper describes a scaling technique that can be used as a teaching tool in engineering courses that involve the development of mathematical models for physical processes. This scaling technique provides a systematic means for achieving the minimum parametric representation of a physical problem. Moreover, since it involves order-of-one scaling, it permits assessing the relative importance of the various terms that appear in a mathematical model. As such, scaling analysis is of considerable value in engineering practice as well. The scaling analysis method is illustrated via an example problem involving Pressure-Swing Adsorption (PSA) for producing oxygen-enriched air. Its utility is demonstrated by showing that it can provide quantitative criteria for invoking simplifying assumptions that oftentimes are made without rigorous justification. Moreover, this example illustrates how scaling analysis can be used to assess the performance of novel process innovations, in this case Ultra-Rapid PSA that is being proposed for providing a portable device for supplying oxygen to patients suffering from Chronic Obstructive Pulmonary Disease (COPD).

I. Introduction

Scaling analysis is a useful technique that involves a systematic method for recasting the describing equations for a physical process in dimensionless form. The end result of a proper scaling analysis is a set of dimensionless equations that describes a physical process in terms of the minimum number of dimensionless parameters. Moreover, a proper scaling analysis insures that the dependent and independent variables and their derivatives are scaled to be of order one. When the describing equations are scaled in this manner, the magnitude of the dimensionless groups that multiply certain terms permits assessing simplifying assumptions that can be invoked in solving the physical problem.

Scaling analysis is particularly useful as a teaching tool since it permits quantifying concepts that are sometimes presented in an intuitive way. For example, the concept of a hydrodynamic boundary layer is often justified using nonquantitative “hand-waving” arguments. It also useful as a teaching tool that provides a systematic method for making simplifying assumptions in the description of a physical problem that oftentimes are made without justification. A knowledge of

scaling analysis can help the engineering educator more effectively teach courses that involve modeling. It also is an invaluable aid in helping engineering students learn subtle engineering concepts more easily.

Scaling analysis is also quite useful in engineering practice. It permits reducing the describing equations for a physical process to their minimum parametric form; that is, in terms of the minimum number of dimensionless parameters. These dimensionless parameters are then useful in scale-up or scale-down analyses such as are involved in wind-tunnel studies of vehicle aerodynamics. The minimum parametric representation also is useful for obtaining generalized correlations from experimental data or numerical simulations. Scaling analysis also permits an initial assessment of the viability of proposed process innovations and thereby can be used to screen alternative methodologies for carrying out physical processes. Finally, scaling can also be used to determine optimal process parameters in engineering design.

Various applications of scaling analysis have been discussed in prior publications by one of the authors [1,2,3]. This paper considers a novel example problem for illustrating scaling analysis, namely Pressure Swing Adsorption (PSA). No scaling analysis has been published for this important separations process. This example provides a meaningful basis for illustrating the utility of scaling analysis to arrive at the minimum parametric representation, and to assess the relative importance of the various terms in a physical model for the PSA process. In particular, it permits assessing how the performance of Ultra-Rapid PSA process might be different.

II. The Scaling Analysis Technique

The following steps are involved in scaling analysis:

1. Write down the complete set of describing algebraic or differential equations including any relevant boundary, initial, and auxiliary conditions.
2. Introduce dimensionless variables for the relevant dependent and independent variables employing arbitrary scale and reference factors; in some cases the relevant dependent variable might be a spatial or time derivative.
3. Introduce the dimensionless variables into the model equations and relevant boundary, initial, and auxiliary conditions.
4. In each equation divide through by the dimensional coefficient of a term that one assumes should be retained in order to assure a physically meaningful solution; this will yield dimensionless groups in front of other terms in each equation that contain the arbitrary scale and reference factors.
5. Determine the unknown scale and reference factors by setting the resulting dimensionless groups equal to one or zero in order to bound the relevant independent variables, and the dependent variables and their spatial and time derivatives, to be of order one; by "order one" we mean that the maximum magnitude of the dimensionless quantity is approximately one; the quantity could in fact be considerably less than one or even zero.
6. The aforementioned process yields the minimum parametric representation of the physical problem; the magnitude of the remaining dimensionless groups permits assessing the relative importance of the various terms in the describing equations. The

dimensionless groups can be used to correlate experimental or numerical data as well as for scale-down or scale-up analyses.

The implementation of scaling analysis will be shown via an example problem, specifically, the Pressure Swing Adsorption (PSA) process used for separating gas feed streams into enriched product streams. Applying scaling analysis to PSA not only provides a practical example problem, but also leads to novel results in terms of innovative modifications of the PSA process.

III. Pressure Swing Adsorption

Pressure Swing Adsorption (PSA) is a separations technology that is used to produce a concentrated gas product stream from a gas feed mixture. We will use scaling analysis both to justify approximations that are oftentimes used in modeling conventional PSA and to assess the viability of a proposed innovation in PSA technology that involves rapid cycling on a microscale that will be referred to as Ultra-Rapid Pressure Swing Adsorption.

This example is a meaningful practical problem to consider. Conventional PSA is used to produce oxygen for both industrial as well as medical applications; indeed, 20% of the world's oxygen production is accomplished by conventional PSA. In particular, conventional PSA is used for critical life support for patients suffering from Chronic Obstructive Pulmonary Disease (COPD). There is considerable motivation to develop a compact portable oxygenator that would greatly improve the quality of life of COPD patients. Ultra-Rapid PSA technology offers this promise since it potentially permits very efficient oxygen production via a device that is a small fraction of the size and weight of current oxygenators.

The PSA process shown in Figure 1 separates air into an oxygen-enriched product and a nitrogen-enriched waste by using a packed bed of particles that selectively adsorb nitrogen relative to oxygen. The air feed to the packed bed is cycled between a high pressure at which adsorption occurs and a low pressure at which desorption occurs. Since the nitrogen is held up on the adsorbent particles relative to the oxygen, the latter passes through the PSA packed bed more rapidly than the nitrogen and thereby is separated from it. Since the process pressure is cycled between high and low values, this process is called "Pressure Swing Adsorption" or PSA.

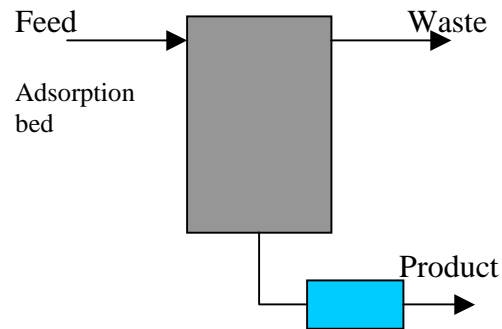

Figure 1: Conventional PSA

Since the focus of this paper is to illustrate the utility of scaling analysis, we will simplify the PSA process by assuming that the feed stream consists of pure nitrogen rather than a mixture of oxygen and nitrogen. This obviates the need to solve the differential species balance equation in addition to the differential overall mass-balance equation. Hence, in the example considered here we seek to determine the pressure in the packed bed of adsorbent particles as a function of axial position and time. From the pressure one can determine the mass of nitrogen adsorbed in the bed

as a function of axial distance and time. We will invoke scaling analysis in order to assess the relative magnitude of the various terms in the differential overall mass balance, and to determine when simplifying assumptions are justified. We also seek to determine how Ultra-Rapid PSA might differ from conventional PSA and how the operating parameters can be chosen to optimize its performance.

IV. Scaling the PSA Process

In the following we will sequentially apply the six-steps involved in the scaling analysis procedure. A subsection will be devoted to each step.

Step 1:

An overall mass balance for a differential length of the packed bed of adsorbent particles shown in Figure 1 yields the following equation:

$$\frac{\varepsilon}{RT} \frac{\partial P}{\partial t} = -\frac{\varepsilon}{RT} \frac{\partial(PU)}{\partial x} - (1-\varepsilon)\dot{q} \quad (1)$$

where P is the pressure, U is the gas velocity, \dot{q} is the rate of nitrogen adsorption per unit volume of adsorbent particles, x is the axial distance, t is time, R is the gas constant, T is the absolute temperature, and ε is the porosity of the packed bed. The first term in the above equation is the accumulation of total mass in the differential volume element; the second term is the advection of mass owing to the pressure-induced gas velocity in the packed bed; the third term is the loss of mass owing to adsorption of nitrogen onto the adsorbent particles within the differential volume element.

The nitrogen adsorption rate \dot{q} in the above equation is given by one of the two following equations:

$$\dot{q} = k(q^E - q) \quad (2)$$

or

$$\dot{q} = \dot{q}^E \quad (3)$$

where k is an adsorption rate constant (units of reciprocal time), q^E (a variable) is the equilibrium nitrogen concentration at the instantaneous pressure (moles per unit volume of adsorbent particles), q is the actual nitrogen concentration on the adsorbent particles at the instantaneous pressure, and \dot{q}^E (a variable) is the equilibrium nitrogen adsorption rate per unit volume of adsorbent particles. Equation 2 is called the Linear Driving Force (LDF) approximation and allows for a nonzero resistance to nitrogen transfer within the adsorbent particles. Equation 3 is an equilibrium adsorption approximation since it assumes a negligible

resistance to nitrogen transfer within the particles and therefore that the adsorbed phase concentration is in instantaneous equilibrium at the pressure in the bed.

The adsorbed nitrogen concentration as a function of pressure is determined by an appropriate adsorption isotherm. Here we will employ the Langmuir isotherm given by the following:

$$q^E = \frac{q^0 l P}{1 + l P} \quad (4)$$

where q^0 is the saturation adsorption value (a constant for a specified gas on a particular adsorbent) and l (units of reciprocal pressure) is the equilibrium constant (characteristic of a specified gas on a particular adsorbent).

The gas velocity in the packed bed of adsorbent particles is determined from Darcy's law given by the following equation:

$$U = -\frac{b}{\mu} \frac{dP}{dx} \quad (5)$$

where b is the Darcy constant (characteristic of the packed bed of adsorbent particles) and μ is the shear viscosity of the gas.

Equation 1 in combination with equation 5 constitute a nonlinear partial differential equation that must be solved for the pressure as a function of x and t . This equation is second-order in x and hence requires two boundary conditions:

$$\text{At } x = 0, \begin{cases} P = P_L + P_A \sin \omega t & \text{for } \frac{n2\pi}{\omega} \leq t \leq \frac{n2\pi + \pi/2}{\omega} & \text{for pressurization} & (6) \\ P = P_L + P_A \sin\left(\frac{\pi}{2} + \omega t\right) & \text{for } \frac{n2\pi + \pi/2}{\omega} \leq t \leq \frac{n2\pi + \pi}{\omega} & \text{for depressurization} & (7) \end{cases}$$

$$P = P_L \quad \text{at} \quad x = L \quad (8)$$

where n is zero or a positive integer. Equations 6 and 7 state that the pressure at the one end of the adsorbent bed is periodically pulsated above and below, respectively, some average pressure P_L depending on whether it is the adsorption or desorption part of the PSA cycle. Equation 8 states that the pressure at the other end of the bed is held constant. Here we have assumed that the average pressure at the upstream end of the packed bed is equal to the constant pressure maintained at the downstream end. During pressurization the pressure increases from P_L to $P_L + P_A$ at the upstream end of the adsorbent bed. This causes flow of nitrogen into the bed at $x = 0$ and adsorption onto the adsorbent particles. During depressurization the pressure decreases from P_L to $P_L - P_A$ at the upstream end of the adsorbent bed. This causes flow of nitrogen from the bed at $x = 0$ and desorption from the particles. Since we seek to describe PSA, which involves periodic pressure swings, it is not necessary to satisfy any initial condition. Equations 1–8

constitute a complete description of the physical process necessary to determine the pressure in the packed bed of adsorbent particles as a function of axial distance and time.

Step 2:

Introduce the following dimensionless variables:

$$\hat{x} \equiv \frac{x}{x_s}; \quad \hat{t} \equiv \frac{t-t_r}{t_s}; \quad \hat{U} \equiv \frac{U}{U_s}; \quad \hat{P} \equiv \frac{P-P_r}{P_s}; \quad \hat{q} \equiv \frac{q}{q_s}; \quad \hat{\dot{q}} \equiv \frac{\dot{q}}{\dot{q}_s} \quad (9)$$

where the subscript s denotes a scale factor and the subscript r denotes a reference factor. Scale factors are introduced in order to normalize the dimensionless variable to be of order one, whereas reference factors are introduced in order to reference the dimensionless dependent or independent variable to zero. Note that we have scaled all the dependent and independent variables. Note also that we have considered the adsorption rate to be a dependent variable that is scaled by \dot{q}_s . It is not necessarily true that the adsorption rate would be scaled by q_s/t_s , since the amount adsorbed might not experience a characteristic change of q_s over the characteristic time t_s . Recall here that our goal is to scale all the above dependent and independent variables to be of order one. The time scale t_s is characteristic of the time over which the pressure swing occurs, which is not necessarily the time for adsorption to occur. Note also that we have introduced reference factors for the pressure and time since we will see that this permits referencing both the dimensionless pressure and time variables to zero.

Steps 3 and 4:

Introduce the dimensionless variables defined by equations 9 into equations 1–8 and divide through by the dimensional coefficient of a term that one assumes should be retained to insure that the model has physical significance in order to obtain the following set of equations:

$$\frac{x_s}{U_s t_s} \frac{\partial \hat{P}}{\partial \hat{t}} = - \frac{\partial}{\partial \hat{x}} \left(\hat{P} \hat{U} \right) - \frac{x_s RT (1-\epsilon) \dot{q}_s}{\epsilon U_s P_s} \hat{\dot{q}} \quad (10)$$

$$\hat{\dot{q}} = \frac{k q_s}{\dot{q}_s} (\hat{q}^E - \hat{q}) \quad (11)$$

or

$$q = \hat{q}^E = \frac{q^0 l P_s}{\dot{q}_s t_s} \left[1 + l P_s \left(\hat{P} + P_r / P_s \right) \right]^{-2} \frac{d \hat{P}}{d \hat{t}} \quad (12)$$

$$\hat{q}^E = \frac{q^0 l P_s}{q_s} \frac{\left(\hat{P} + P_r / P_s \right)}{1 + l P_s \left(\hat{P} + P_r / P_s \right)} \quad (13)$$

$$\hat{U} = - \frac{b P_s}{\mu x_s U_s} \frac{d \hat{P}}{d \hat{x}} \quad (14)$$

$$\text{At } \hat{x}=0, \left\{ \begin{array}{l} \hat{P} = \frac{P_L - P_r}{P_s} + \frac{P_A}{P_s} \sin \omega t_s \left(\hat{t} + \frac{t_r}{t_s} \right) \quad \text{for } \frac{n2\pi}{\omega t_s} - \frac{t_r}{t_s} \leq \hat{t} \leq \frac{n2\pi}{\omega t_s} - \frac{t_r}{t_s} + \frac{\pi}{2\omega t_s} \\ P = \frac{P_L - P_r}{P_s} + \frac{P_A}{P_s} \sin \left[\frac{\pi}{2} + \omega t_s \left(\hat{t} + \frac{t_r}{t_s} \right) \right] \quad \text{for } \frac{n2\pi}{\omega t_s} - \frac{t_r}{t_s} + \frac{\pi}{2\omega t_s} \leq \hat{t} \leq \frac{n2\pi}{\omega t_s} - \frac{t_r}{t_s} + \frac{\pi}{\omega t_s} \end{array} \right. \quad (15)$$

$$\quad (16)$$

$$\hat{P} = \frac{P_L - P_r}{P_s} \quad \text{at} \quad \hat{x} = \frac{L}{x_s} \quad (17)$$

Note in equation 10 that we have elected to divide all the terms by the coefficient of the advection term since this term must be retained if we are to determine the axial dependence of the pressure. If the subsequent choice of the scale factors results in obtaining a very large dimensionless group in front of one of the other terms, thereby implying that it is larger than the principal term, it indicates that one or more of our scales is incorrect. This is the advantage of scaling all the relevant variables to be of order one. That is, the dimensionless groups then multiply dimensionless variables and their derivatives that are of order one. If a dimensionless group is found to be very large, it implies that some assumption in the analysis regarding either the principal terms or the scale factors was incorrect.

Step 5:

Equations 10, 11 and 13–17 for the case of intraparticle-controlled adsorption, and equations 10 and 12–17 for adsorption equilibrium contain 12 dimensionless groups that involve 8 undetermined scale and reference factors. We can set 8 of these dimensionless groups equal to one or zero (in the case of determining a reference factor) in order to scale the relevant variables and their derivatives to be of order one. However, this cannot be done arbitrarily. One must make some assumptions as to the proper groups to set equal to one and then determine if this choice was correct by evaluating the remaining dimensionless groups to be if they are also bounded of order one. We will make the following choices:

$$\frac{L}{x_s} = 1 \quad \Rightarrow \quad x_s = L \quad (18)$$

$$\frac{n2\pi}{\omega t_s} - \frac{t_r}{t_s} = 0 \quad \Rightarrow \quad t_r = \frac{n2\pi}{\omega} \quad (19)$$

$$\frac{\pi}{2\omega t_s} = 1 \quad \Rightarrow \quad t_s = \frac{\pi}{2\omega} \quad (20)$$

$$\frac{P_L - P_r}{P_s} = 0 \Rightarrow P_r = P_L \quad (21)$$

$$\frac{P_A}{P_s} = 1 \Rightarrow P_s = P_A \quad (22)$$

$$\frac{q^0 l P_s}{q_s} = 1 \Rightarrow q_s = q^0 l P_A \quad (23)$$

and

$$\frac{k q_s}{\dot{q}_s} = 1 \Rightarrow \dot{q}_s = k q^0 l P_A \quad (24)$$

or

$$\frac{q^0 l P_s}{\dot{q}_s t_s} = 1 \Rightarrow \dot{q}_s = \frac{2 q^0 l P_A \omega}{\pi} \quad (25)$$

$$\frac{b P_a}{\mu x_s U_s} = 1 \Rightarrow U_s = \frac{b P_A}{\mu L} \quad (26)$$

Step 6:

The scale and reference factors defined by equations 18–26 can be determined using the characteristic values for the physical properties and system parameters given in Table 1 for both conventional and Ultra-Rapid PSA. Before preceding any further it is convenient to determine whether the intraparticle transfer rate or equilibrium adsorption determines the characteristic adsorption rate scale; that is, whether equation 24 or equation 25, respectively, determines \dot{q}_s .

Table 1: System Parameters for Conventional and Ultra-Rapid PSA

System Parameters	Conventional PSA	Ultra-Rapid PSA
b (m ²)	1.33×10^{-9}	2.71×10^{-15}
k (s ⁻¹)	19	1.5×10^6
l (m ² /N)	5.15×10^{-7}	5.15×10^{-7}
L (m)	1.0	2.0×10^{-4}
q^0 (mol/m ³)	2.7×10^3	2.7×10^3
P_A (Pa)	1×10^5	0.4×10^5
P_L (Pa)	1×10^5	1×10^5
R (Pa·m ³ /mol·K)	8.314	8.314
T (K)	298	298
ε	0.35	0.35
μ (Pa·s)	1.83×10^{-5}	1.83×10^{-5}
ω (rad/s)	0.06	157

This can be assessed by dividing equation 25 by equation 24. This ratio is a measure of the time scale for intraparticle transfer to that for adsorption equilibrium. The criterion for assuming equilibrium adsorption is then given by the following:

$$\frac{2\omega}{\pi k} \ll 1 \quad (27)$$

That is, equilibrium adsorption is favored by large intraparticle transfer coefficients and by longer cycle times. Table 1 summarizes the characteristic values of the physical properties and system parameters for both conventional and Ultra-Rapid PSA. These characteristic values, when substituted into equation 27, indicate that both processes operate under conditions of rapid adsorption equilibrium. Hence, in the following we will assume that the adsorption rate scale is determined by equation 25.

When the scale and reference factors determined by equations 18–23 and 25–26 are substituted into equations 10–17, the minimum parametric representation of the problem is obtained:

$$\frac{2\omega\mu L^2}{\pi b P_A} \frac{\partial \hat{P}}{\partial \hat{t}} = -\hat{P} \frac{\partial}{\partial \hat{x}} (\hat{P} \hat{U}) - \frac{2\omega RT(1-\varepsilon)q^0 l \mu L^2}{\pi \varepsilon b P_A} \hat{q} \quad (28)$$

$$q = \hat{q}^E = \left[1 + l P_A \left(\hat{P} + P_L / P_A \right) \right]^{-2} \frac{d\hat{P}}{d\hat{t}} \quad (29)$$

$$\hat{q}^E = \frac{\hat{P} + P_L / P_A}{1 + l P_A \left(\hat{P} + P_L / P_A \right)} \quad (30)$$

$$\hat{U} = -\frac{d\hat{P}}{d\hat{x}} \quad (31)$$

$$\text{At } \hat{x} = 0 \left\{ \begin{array}{ll} \hat{P} = \sin \frac{\pi}{2} (\hat{t} + 4n) & \text{for } 0 \leq \hat{t} \leq 1 \quad \text{pressurization} \\ \hat{P} = \sin \left[\frac{\pi}{2} + \frac{\pi}{2} (\hat{t} + 4n) \right] & \text{for } 1 \leq \hat{t} \leq 2 \quad \text{depressurization} \end{array} \right. \quad (32)$$

$$\quad (33)$$

$$\hat{P} = 0 \quad \text{at} \quad \hat{x} = 1 \quad (34)$$

The four dimensionless groups remaining in equations 28–34 are summarized below:

$$N_1 \equiv \frac{2\omega\mu L^2}{\pi b P_A} \quad (35)$$

$$N_2 \equiv \frac{2\omega RT(1-\varepsilon)q^0 l \mu L^2}{\pi \varepsilon b P_A} \quad (36)$$

$$N_3 \equiv l P_A \quad (37)$$

$$N_4 \equiv \frac{P_A}{P_L} \quad (38)$$

The group N_1 permits assessing the relative important of the unsteady-state term in the overall mass balance. The group N_2 permits assessing the importance of mass loss owing to adsorption in the overall mass balance. The group N_3 permits determining when the Langmuir adsorption isotherm reduces to a linear relationship, that is, a Henry's law type approximation. The group N_4 is a measure of the relative magnitude of the pressure swing. If values of the physical properties and process parameters are known, the groups N_1 , N_2 , N_3 , and N_4 can be calculated to assess the relative importance of various terms in describing equations.

V. Discussion and Conclusions

Table 2 summarizes the values of these four groups for both conventional PSA and Ultra-Rapid PSA based on the characteristic physical properties and process parameters given in Table 1.

Table 2: Characteristic Dimensionless Groups for Conventional and Ultra-Rapid PSA

Dimensionless group	Conventional PSA	Ultra-Rapid PSA
N_1	0.04	1.35
N_2	0.035	4.3
N_3	0.05	0.02
N_4	1.00	0.40

One sees that these two processes are markedly different. The magnitude of N_1 indicates that conventional PSA can be assumed to be quasi-steady-state; that is, one can safely neglect the unsteady-state term in the overall mass balance in determining the pressure distribution. However, this simplification cannot be made for Ultra-Rapid PSA. The magnitude of N_2 indicates that one can ignore the effect of the gas adsorption in solving the overall mass balance for conventional PSA. However, this term is significant for Ultra-Rapid PSA owing to its more rapid adsorption rate and the superior properties of the adsorbent material, such as smaller adsorbent particle size, the monolith structure of the adsorption bed, and the active binder that holds the small adsorbent particles together. For Ultra-Rapid PSA, the absorption term is so important that its presence in the total mass balance is essential. The magnitude of the group N_3 indicates that the adsorption equilibrium can be described by a simple linear relationship for both conventional as well as Ultra-Rapid PSA.

This example indicates the power of scaling analysis as a systematic method for achieving the minimum parametric representation of a physical process. Moreover, by employing the systematic scaling method to insure that the dependent variables and their derivatives are of order one, it is possible to assess the relative importance of the various terms that appear in the describing equations for a physical process. In particular, scaling analysis provides quantitative criteria for invoking simplifying assumptions. In the example problem presented here for pressure swing adsorption (PSA), scaling analysis was used to develop a quantitative criterion for assuming quasi-steady-state, namely

$$N_1 = \frac{2\omega\mu L^2}{\pi b P_A} \ll 1 \quad (40)$$

Scaling analysis also provided a quantitative criterion for when the mass loss owing to adsorption could be ignored in the overall mass balance used to determine the pressure distribution in the PSA device, name

$$N_2 = \frac{2\omega RT(1-\varepsilon)q^0 l \mu L^2}{\pi \varepsilon b P_A} \ll 1 \quad (41)$$

Scaling analysis also provides a quantitative way to determine the optimal design parameters for PSA. Since the group N_2 for Ultra-Rapid PSA is somewhat larger than unity, it suggests that the characteristic pressure swing P_A does not occur over the full adsorption-bed length L . Rather, for Ultra-Rapid PSA the adsorption is so efficient that the pressure undergoes a characteristic change over a distance somewhat less than the full bed length. This implies that for the design parameters given for Ultra-Rapid PSA in Table 1, the adsorption bed is not being fully utilized. Hence, either a larger pressure swing P_A or a slower cycle frequency ω could be employed to more fully utilize the adsorption bed. Feasible values for either the pressure swing or cycle time can be determined by setting N_2 equal to one. More efficient use of the adsorption bed can be achieved for Ultra-Rapid PSA by increasing the pressure swing to $P_A = 1.72 \times 10^5$ Pa or by decreasing the cycle time to $\omega = 36.5$ rad/s.

In addition, scaling analysis provided a quantitative criterion for when the Langmuir adsorption isotherm could be simplified and approximated via a linear relationship, namely

$$N_3 = l P_A \ll 1 \quad (42)$$

The approximations of quasi-steady-state, negligible adsorption, linear adsorption equilibrium behavior, *etc.*, are well known in the design of conventional PSA [4]. However, these assumptions are often made without providing any quantitative criteria to assess their validity. Scaling analysis is a systematic method for developing these criteria as shown in this paper.

In practice, the error encountered in making a particular assumption based on scaling analysis is on the order of the size of the dimensionless group used to provide the quantitative criterion for the approximation; that is, if the dimensionless group is of order 0.1, 0.01, *etc.*, the error encountered in making the approximation will be 10%, 1%, *etc.*, respectively. This conclusion follows directly from the scaling methodology whereby each term is of order one. Hence, if a dimensionless group multiplying a particular term is small, the error encountered when this term is ignored is on the order of the discarded term.

Scaling analysis is a valuable tool in engineering teaching. It can be used to justify simplifying assumptions such as those considered in the example presented in this paper and in prior papers on this subject by one of the co-authors [1,2]. Moreover, it can be used to introduce subtle concepts such as creeping flow or boundary layer theory in fluid mechanics and penetration theory in mass transfer [1]. Scaling analysis is also quite useful in engineering practice since it can be used to achieve the minimum parametric representation of a physical problem and thereby

to provide the dimensionless groups that can be used to correlate experimental data or the results of a numerical simulation [3]. The dimensionless groups resulting from scaling analysis can also be used in scale-up and scale-down analyses such as for wind tunnel studies of aerodynamics. Finally, as shown in this example, scaling analysis can be used to estimate the optimal design parameters for a process.

Bibliography

1. Krantz, W.B., Scaling Initial and Boundary Value Problems as a Teaching Tool for a Course in Transport Phenomena, *Chemical Engineering Education*, **4**(3), 145 (1970).
2. Krantz, W.B. and J.G. Szechowski, Scaling Initial and Boundary Value Problems – A Tool in Engineering Teaching and Practice,” *Chemical Engineering Education*, **28**(4), 236-253 (1994).
3. Krantz, W.B., Dimensional Analysis: A More Effective Way to Teach and Implement It, *Chemical Engineering Education*, 216-221, Summer (2000).
4. Ruthven, D.M., S. Farooq, and K.S. Knaebel, *Pressure Swing Adsorption*, VCH Publishers, Inc., New York, NY (1994).

EUGENE M. KOPAYGORODSKY

Eugene Kopaygorodsky is presently an M.S. degree student in the Department of Chemical Engineering at the University of Cincinnati. He received a B.A. in business economics in 1997 and a B.S. in chemistry in 1998 from the University of Cincinnati. His current research is focused on developing a mathematical model for ultra-Ultra-Rapid PSA processes.

WILLIAM B. KRANTZ

William B. Krantz is a Professor of Chemical Engineering and the Rieveschl Ohio Eminent Scholar at the University of Cincinnati. He received a B.A. in chemistry in 1961 from Saint Joseph's College (Indiana), a B.S. in chemical engineering in 1962 from the University of Illinois (Urbana), and a Ph.D. in chemical engineering in 1968 from the University of California (Berkeley). He is a registered Professional Engineer. He received the ASEE George Westinghouse and Rocky Mountain Section Teaching Awards and is a Fellow of ASEE.

VADIM V. GULIANTS

Vadim Guliants is an Assistant Professor of Chemical Engineering at the University of Cincinnati. He received a Diploma in chemistry in 1987 from Moscow State University, an M.A. in 1993 and a Ph.D. in 1995, both in chemistry, from Princeton University. He worked for four years at Praxair, Inc., where he investigated gas separation in low silica zeolites. He came to the University of Cincinnati in 1999. His current research interests include the development of novel materials for adsorptive separations and catalysis.