

Teaching In-Circuit Test (ICT) Techniques in Electrical Engineering Technology

Glenn R. Blackwell
Purdue University, W. Lafayette, IN

Abstract

This paper describes the teaching and use of an industry-standard electronic test technique in a EET program. In-circuit test (ICT) is used in industry to perform tests on printed circuit assemblies during their assembly phase. Its purpose is to find both component and manufacturing problems before the assembly is completed. In a EET program, ICT can be used for the same purpose especially in an electronics project course. This teaches the student the basics of performing a test that is used throughout the electronics industry as well as introducing the student to the concept of testing an assembly before power is applied.

Introduction

In-circuit test (ICT) is considered in industry to be a manufacturing verification tool. It tests individual components and the components' interconnections to a substrate, usually a printed circuit board. ICT fits into an overall test scheme that includes both bare board and incoming parts testing, ICT, and final functional tests.

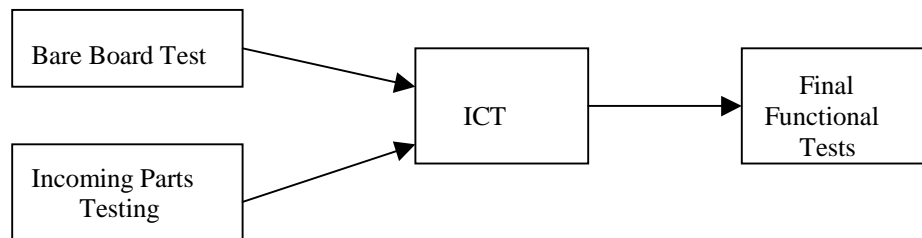

Figure 1. Overall electronic test scheme.

In applying this scheme within a freshman EET projects course, the students are provided a circuit board and parts kit for a triple-output power supply. They then check the bare board for trace continuity, shorts between traces, and proper drilled-hole count prior to assembly. In a similar fashion they check the parts which can be tested with an ohmmeter, such as resistor values, diode verification, and ability of capacitors to accept a charge.

Generally, ICT has two parts, tests performed before power is applied, and tests performed after power is applied. The basics of these tests are described below. If the power-off tests are performed on a separate test system, the power-off test system is generally known as either an In-circuit Analyzer (ICA) or a Manufacturing Defects Analyzer (MDA). Access to components

for both ICA/MDA and ICT tests in industry is through a bed-of-nails fixture, which can allow access to each node of the circuit assembly to be tested. In an educational lab, access is typically by selecting appropriate node pairs to test with a DMM or other test equipment.

Power-off Tests

Whether performed by an ICA/MDA system, an ICT system, or with a DMM, power-off tests are intended to find these common problems and verify correct assembly:

- Shorts between traces and/or component leads
- Open circuits (“opens”) where electrical continuity should exist
- Values of resistors in the circuit.
- Test for jumpers/switches in the correct location/setting
- Test for presence/absence of passive components
- Do limited testing for presence/absence of active analog components
- Do limited testing for component values

Many of these tests are performed in a manner analogous to basic testing with an ohmmeter. Shorts, opens, jumpers, switches and resistor tests are basic ohms tests. Presence of passive components are variations of ohms’ tests, with capacitors in the proper location testing as an increasing resistance, and inductors testing as a low ohms reading. Certain analog components will test as resistance values, such as the ~4K which is present between the output and ground terminals of a 7805 voltage regulator.

Power-on Tests

The In-circuit Test (ICT) system uses a guarding principle to measure the performance of individual electrical and electronic components. It performs these tests by electrically isolating the component to be tested (frequently called the device under test, or DUT). In addition to all of the tests listed above under Power-off Tests, the ICT can perform these additional tests:

- Mis-oriented analog component
- Mis-oriented digital component
- Wrong analog component
- Wrong digital component
- Capacitance and inductance values
- Transistor beta
- “Stuck” process bus
- Digital component timing

Obviously both power-off and power-on tests are of value to any electronics manufacturer. A student in a EET program needs to understand the basics of these tests, so that s/he has an understanding of manufacturers’ tests, and to that s/he can perform some of these tests when assembling a project, thereby finding problems before power is applied in the overall project system, with the accompanying risk of destroying all or part of the circuit. The power-on tests are difficult to do, since the guarding techniques used in industrial ICT systems are difficult to duplicate on a lab bench, especially at the freshman level. However, the student will have an understanding of the hierarchy of the in-circuit analysis and tests, and begins to understand what tests his/her lab equipment will support.

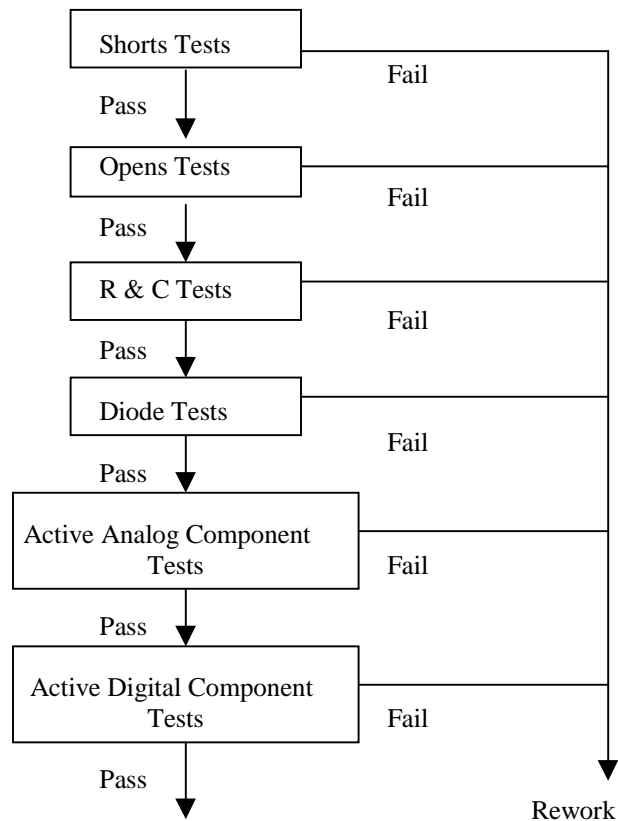

Figure 2. Hierarchy of in-circuit analysis and test.

Testing in a Freshman EET Course

As noted in earlier paragraphs, the primary testing performed in Purdue's freshman EET course is performed with a DMM, and consists of the following tests:

- Bare-board tests for shorts and opens
- Basic parts testing, including resistor values, diode F/R tests, and capacitor charging
- In-circuit analysis after parts are soldered to the board, which verify that parts are in the proper location, that diodes are in the proper orientation, and that capacitors will still accept a charge from the ohmmeter.

The student has the power supply schematic and the board layout. S/he is then expected to use these to develop a series of node-pairs across which components have been soldered. For each of these node pairs, s/he will predict the expected test results. Having done this, the student will then test the assembled board with a DMM. An example of a node pair, the expected results, and actual results are shown below.

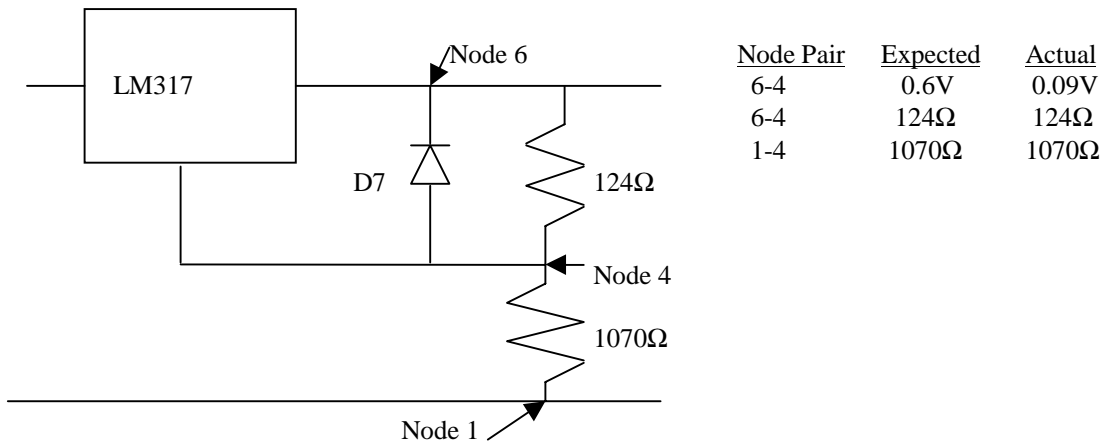

Figure 3. Node pair examples.

As can be seen, the student predicted the diode would be measured at the 6-4 node pair. However, the 124Ω resistor in parallel with the diode prevented the diode test mode from operating properly. The diode-test mode of the DMM showed a low voltage drop due to the resistor. In the resistance mode the resistor tested properly since its resistance is much lower than the diode's and the parallel combination resulted in the 124Ω resistor dominating and therefore measuring correctly.

Predicting the test results properly requires that the student have a basic understanding of series and parallel circuits, although numerical calculations of R//diode are not expected, nor are R//C which also occurs in the LM317 circuit. As the testing gets more involved with active components, the student learns that certain active components beyond transistors and diodes can be tested to some degree with the DMM. For example, an ohmmeter test across the output and ground terminals of a 7805 voltage regulator will result in a reading of ~4.5V. While this reading may vary among different manufacturers of 7805 regulators, the student does learn that a reading of 100Ω or 100KΩ does indicate a problem with the component. These applications of basic circuit principles help the student appreciate material learned in their basic circuits course.

In-class discussions also present test software examples. These help the students understand the scope of test systems which exist in industry.

Overall, the students' reception of the testing information is good. Since the class typically includes 60-100 students, each semester results in some bad components and assembly mistakes being detected by even our limited testing. Since some of their own colleagues find and correct errors/problems as a result of the testing, the students feel the testing is worthwhile.

Bibliography:

-----; "Just Enough Test". John Fluke Mfg. Co., Inc. Everett, WA, 1991

Bateson, John; In-Circuit Testing. Van Nostrand Reinhold Co., New York, 1985.

Kolts, B.S.; "Matching Test Software with Test Applications". Electronic Packaging and Production, Feb. 1998.

Biography:

Glenn R. Blackwell, P.E.

Associate Professor, Electrical Engineering Technology

Purdue University, Knoy 1415

W. Lafayette, IN 47907-1415

phone: 317-494-7726

e-mail: gblack@purdue.edu

fax: 317-496-1354

Glenn Blackwell currently is teaching in the areas of project courses, surface mount technology (SMT), and electronic manufacturing. To stay up-to-date in the SMT and manufacturing areas, he spent the 92-93 school year at Delco Electronics, Kokomo, IN, as a Senior Project Engineer in their Powertrain Electronics Manufacturing Development Group. He supervises design projects in both the freshman and senior years. He is a registered Professional Engineer in Ohio and Indiana, and consults in the areas of SMT and UL compliance.