



The Importance of Having a Critical Thinking Hands-On Project for Students in Electronic Communications Course

Dr. Stephen E. Frempong, State University of New York - Canton

Stephen Frempong, Ph.D., P. Eng(uk), NCE, CET Professor and Head of Department Electrical Engineering Technology & Engineering Science State University of New York at Canton 34 Cornell Drive Canton, New York 13617 frempongs@canton.edu sfrempong@ieee.org Tel: 315-386-7211

The importance of having a critical thinking hands-on project for students in Electronic Communications course

This paper discusses one of the projects in Electronic Communications II course which gives students the opportunity to think and apply their knowledge in electronics, communications and mathematics to design, build and test frequency modulated communication transmitter. The course is also designed to meet ABET general criteria 3: Student Outcomes (b, d, e). The transmitter consists of four blocks. There is audio source block which is a computer to provide the audio signal that needs to be modulated, a frequency modulator circuit that is used to combine both the audio and the high frequency carrier, a high frequency oscillator circuit that generates above 88MHz and below 108MHz carrier, a power amplifier to enhance the frequency modulated signals, and finally to an antenna to radiate the electromagnetic signals.

Students must first design, build and test the high frequency oscillator circuit that is capable of generating a carrier frequency above 88MHz and below 108MHz. Teamwork is encouraged so mostly two students work in a team, but individual who prefers to work on this project by themselves are allowed to do so. When student fails in the design of the tank circuit to generate the expected frequency (88MHz to 108MHz) range for modulation, that team or individual is allowed to submit the detail project paper including problems encountered, and do PowerPoint presentation. However, if your project did not work as expected, you or your team losses 50% of the points assigned to that part of the project. After successfully building and testing the oscillator circuit, the students build and test the required (FM) modulator circuit and the power amplifier which are all provided to students, and these circuits do not have a design component. Students connect all circuits together, and to antenna which is 8 inches magnetic wire (AWG #19) to transmit frequency modulated signal to several AM/FM radio receivers located in the electronics laboratory. These FM communication receivers (88MHz to 108MHz) band were constructed as project by each student in the first telecommunications course (ELEC225).

This project is designed for four weeks, and each team or individual student submits a complete report, and also do

PowerPoint presentation including demonstration of the project to students and faculty who are invited to the presentation.

Students are graded on successful completion of the FM transmitter, detail project report, and PowerPoint presentation (Quality/Communication).

Table 1 Project Grading

Successful Project Design, Construction and Demonstration	Project Detail Report	PowerPoint Presentation (Oral Communication, and Quality)
100 (Points)	40 (Points)	60 (Points)
Total		200 (Points)

This course is offered after students have completed Electronic Circuits, Telecommunications, and Electronic Communications I. As such, students are expected to have knowledge in Oscillators, Amplifiers, Modulator circuits, and etc. For evaluation purpose the target is 160 points, and 80% of students are expected to meet this target.

Figure1- Frequency Modulated (FM) transmitter

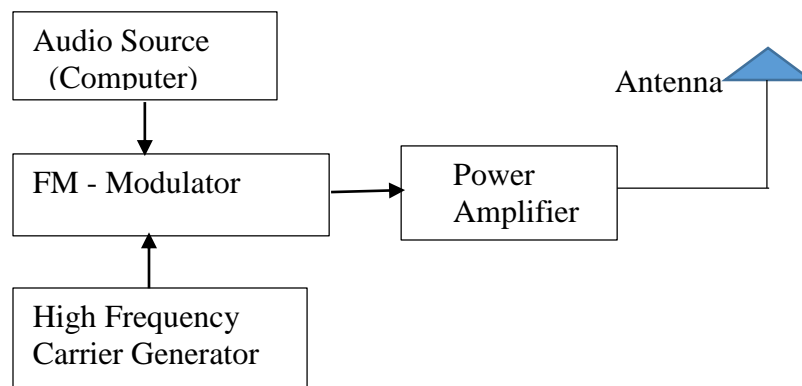

Audio Source Block:

The audio source is a computer to provide the audio information that needs to be transmitted. Some students have used their smart phones as audio source for this project.

FM Modulator Block:

Frequency modulator circuit is provided to students to build and test without design component.

Power Amplifier:

Class- C Power Amplifier is provided to students to build and test without design component.

High Frequency Carrier Generator:

Students are required to use Colpitts Oscillator where the tank circuit needs to be designed. The tank circuit calculations and design determines whether the oscillator circuit will be able to generate high carrier frequency above 88MHz and below 108MHz which is the most difficult part of the project and requires critical thinking. Students cannot use already made inductor for the oscillator tank circuit. American Wire Gauge (AWG) #18 magnetic wire is available and recommended for the design of the inductor (L) in the frequency determining tank. Those students who are unsuccessful in designing the high frequency oscillator circuit to generate enough carrier frequency for modulation, have no chance of being able to transmit to the FM receiver bandwidth 88MHz to 108MHz.

Design Information Provided to Students:

Antenna:

American Wire Gauge AWG #19 (8 inches) is used for the antenna.

Designing the required inductor for the tank of the Colpitts oscillator circuit:

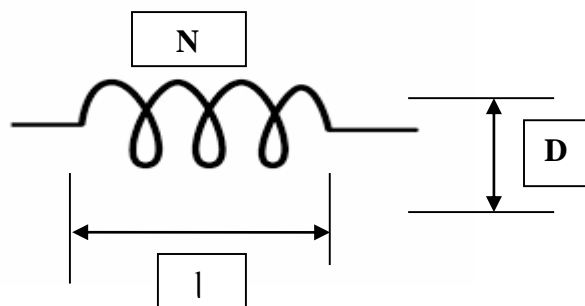

$$\text{Inductance (L)} = \frac{\mu r N^2 A (1.26 \times 10^{-6})}{l}$$

$$\text{Area (A)} = \frac{\pi D^2}{4}$$

μr = Permeability of the core (Air = 1)

Absolute permeability of Air = 1.26×10^{-6}

L = inductance, in μH

N = number of turns of coil

A = cross sectional area of coil, in sq. inches

l = length of coil, in inches

D = Coil diameter in inches

Use AWG 18 to design your inductor (L)

The total capacitance for the Colpitts Oscillator tank circuit can be calculated (series) by:

$$C_t = \frac{C_4 \times C_5}{C_4 + C_5}$$

$$\text{frequency of oscillation } f_r = \frac{1}{\sqrt{2\pi L C_t}}$$

Students can select a frequency within the 88MHz and 108MHz, or use the frequency suggested by instructor.

$$\text{Inductance (L)} = \frac{1}{4\pi^2 C_t f^2}$$

$$\text{Number of turns (N)} = \frac{\text{Length of coil (l)} \times \text{inductance (L)}}{\text{Area} \times 1.26 \times 10^{-6}}$$

Instructor suggested the following:

- Frequency (f_r) = 103 MHz
(This is about the midpoint between 88MHz and 108MHz, which gives student more room not to Exceed or fall below the frequency band after modulation)

- Inductor (coil) diameter using #2HB pencil and AWG #18 is about = 0.4 inches
- Coil length is determined by student after number of turns is calculated. Note: Stretching the coil will have effect on frequency.
- C4 and C5 must be replaced with student calculated values.

Figure 2 – Colpitts Oscillator Circuit

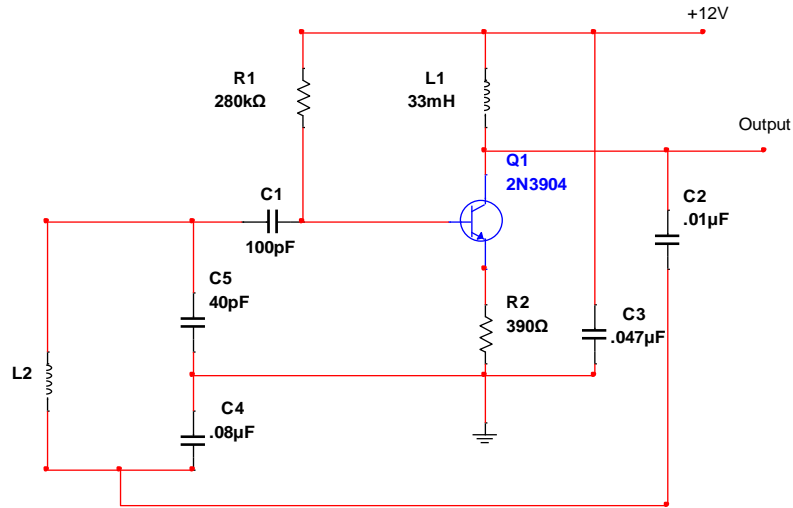

Figure 3 - FM Modulator Circuit

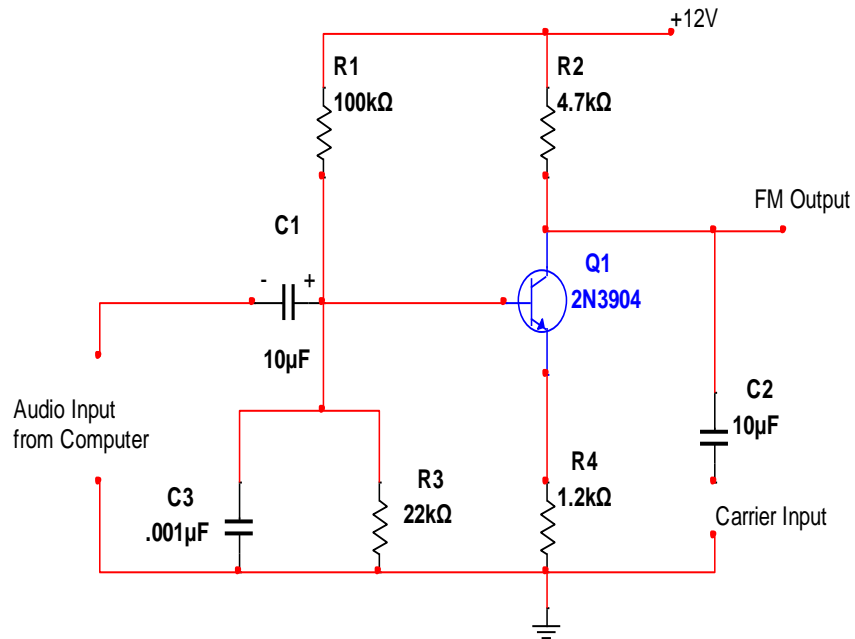

Figure 4 – Class - C Power Amplifier Circuit

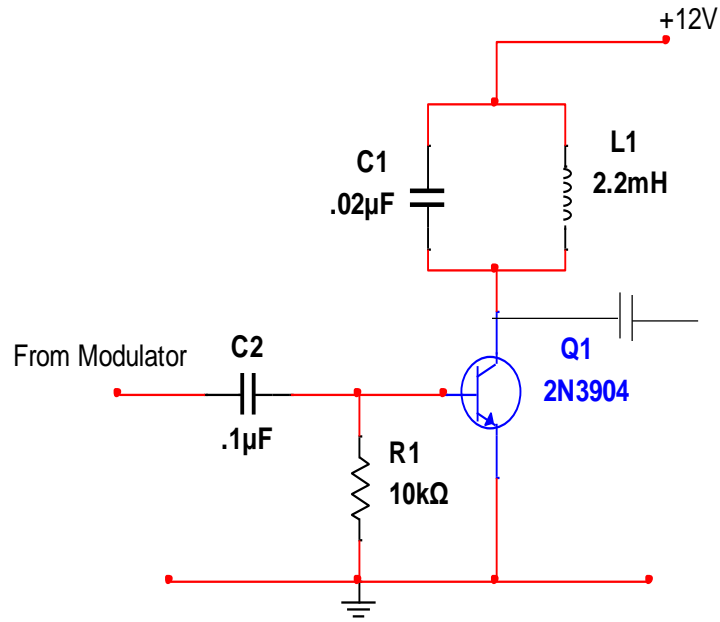

Figure 5- Construction of the high frequency oscillator circuit

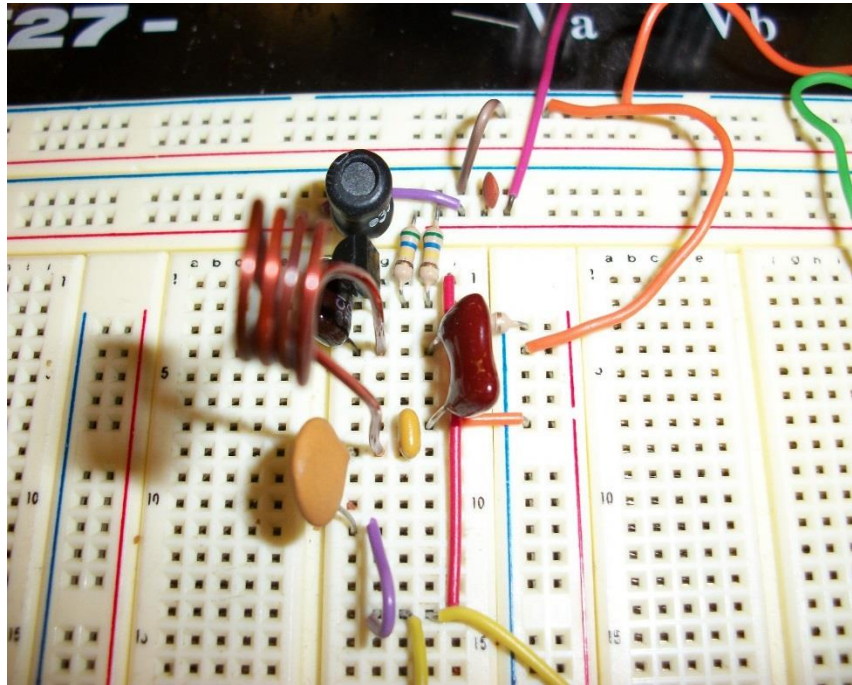
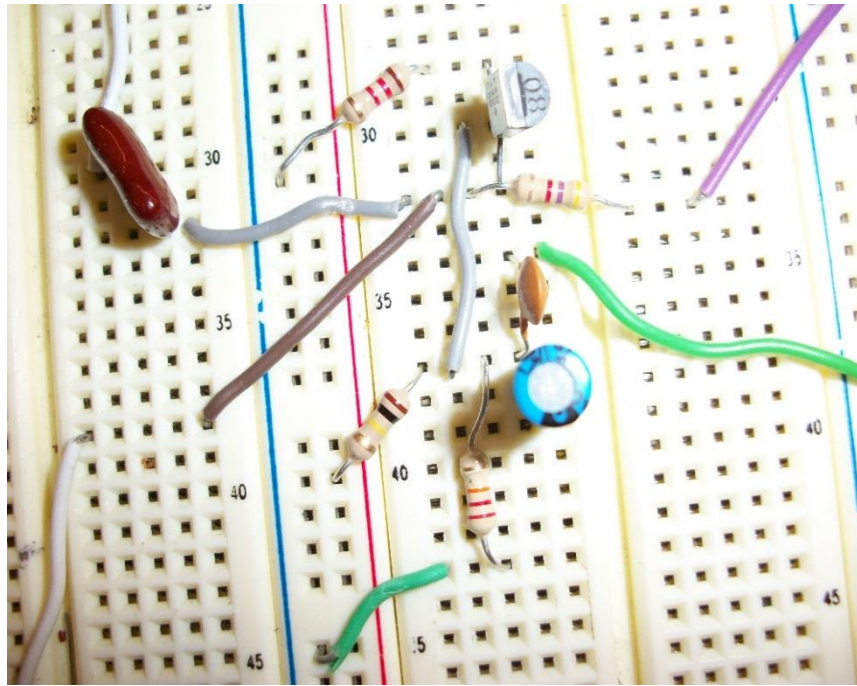

Figure 6- Construction of the modulator circuit



Modulation plays an important role in all communication transmitters, and students need to gain hands-on experience building and testing the modulator circuit.

Figure 7- Construction of Class-C Amplifier

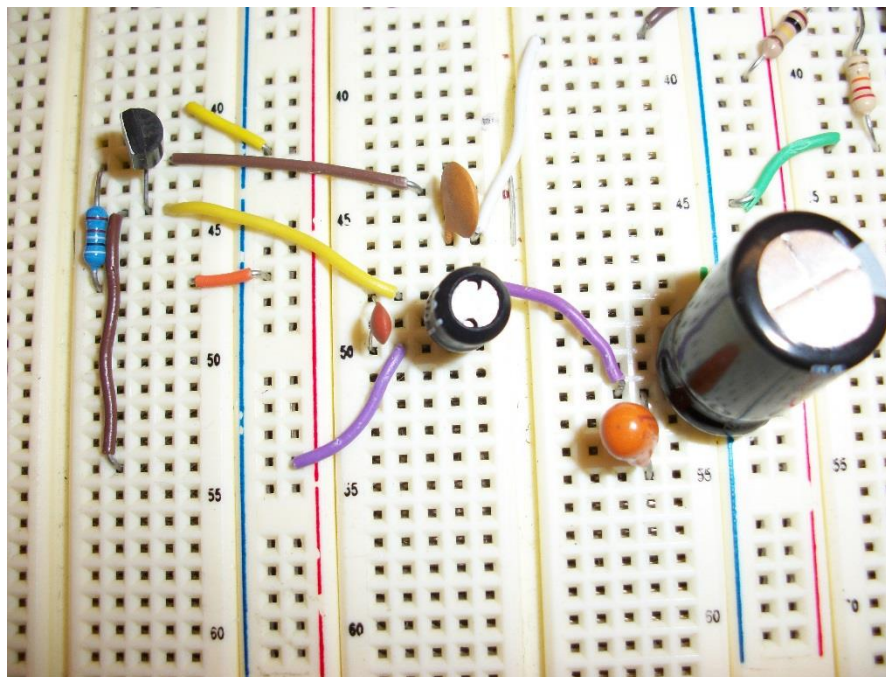

Figure 8- Connecting all three circuits together

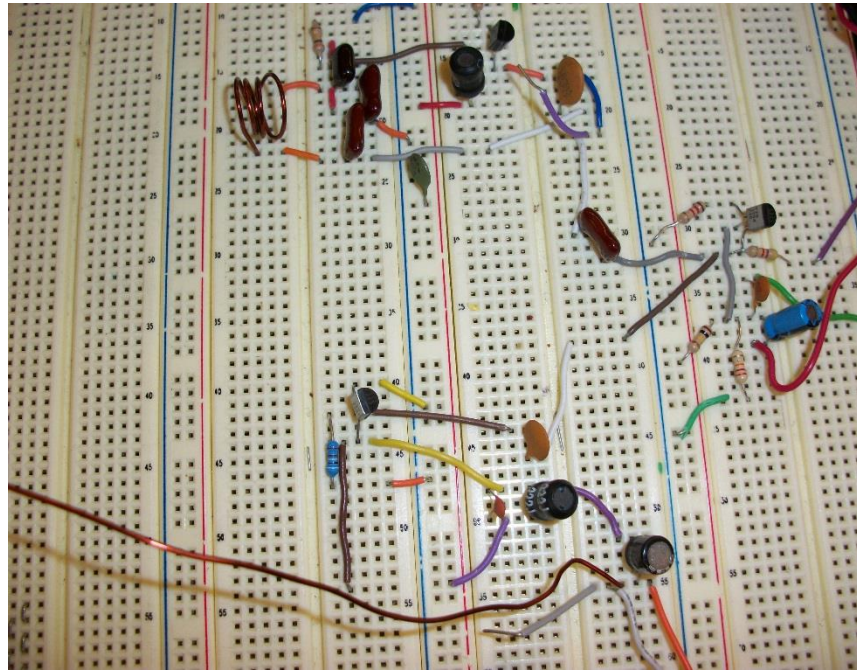
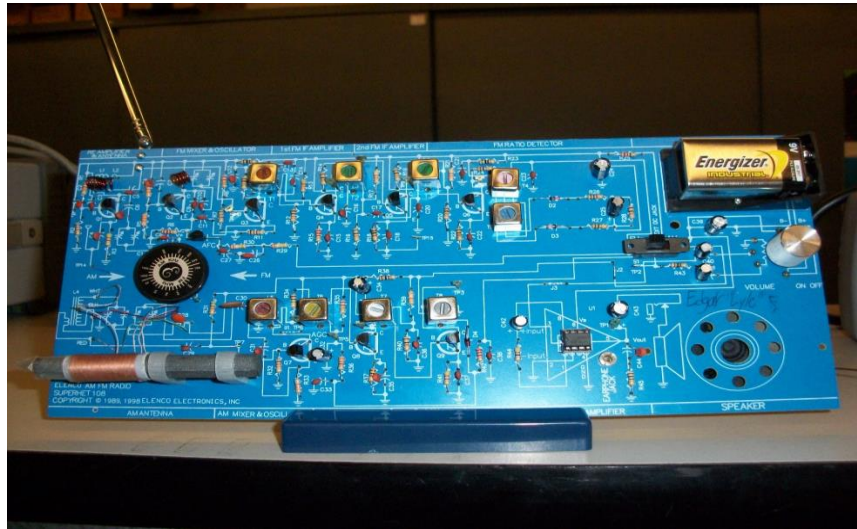

Figure 9- Successful Construction and Operation of FM Communications Transmitter



Figure 10 - AM/FM Communication Receiver



The AM/FM communication receiver is another project constructed by the students from previous telecommunications course (ELEC225) during their fourth semester. The students used the communication receiver to intercept the signals from the FM communication transmitted.

Performance Indicators

Student Project Teams	Project Success Demonstration (100 point)	Project Report (40) points	PowerPoint Presentation (60 points)	Total (200) points
Team (A)	100	37	50	187
Team(B)	100	35	40	175
Team (C)	100	30	45	175
Team (D)	50	38	48	136
Team (E)	100	40	45	185
Team (F)	100	36	55	191

Project Assessment:

83.3% of the students in this course scored above 160 points on this project, so overall target (80%) exceeded. There were 12 students total in both fall and spring semesters, and two students worked together as a team. The 16.7% that did not meet the target (team D) in the fall 2015, had difficulty designing and building the tank circuit to generate the high frequency (88-108MHz) needed

for modulation. However, the two students passed the course, but not with the grade they had expected.

Student Survey	Excellent	Very Good	Good	Poor
How will you rate this project in terms of skills and knowledge in electronic communications gained towards your educational objectives?	✓	✓	✓	
Number of students who selected excellent, very good, good, or poor	8	3	1	
Percentages	66.7%	25%	8.3%	
Total number of students : 12				

3-D Pie Graph for Student Survey

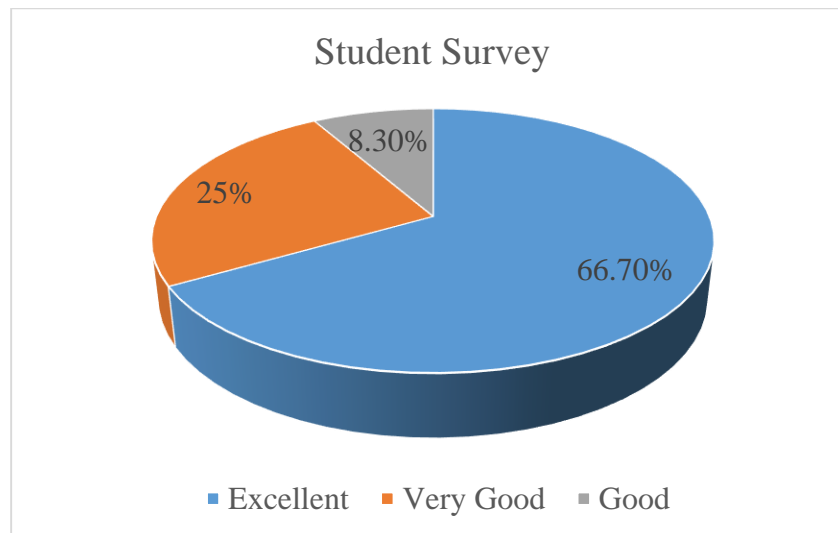

Analysis of student survey:

- (1) The student survey shows that 66.7% indicated the skills and knowledge in electronic communications is excellent, and their educational objectives are being fulfilled as a result of this course.
- (2) The survey also shows that 25% of the students indicated that the skills and knowledge received in this project is very good, and 8.3% indicated that it was good as shown in the 3-D pie graph.

This course is designed to satisfy ABET General Criteria 3:
Student Outcomes (b, d, e) -

(b) An ability to select and apply a knowledge of mathematics, science, engineering, and technology to engineering technology problems that require the application of principles and applied procedures or methodologies;

(d) An ability to design systems, components, or processes for broadly-defined engineering technology problems appropriate to program educational objectives;

(e) An ability to function effectively as a member or leader on a technical team.

Project improvement plan:

- (1) Instructor will ask students to modify the frequency tank circuit after the initial success to generate three specific frequencies (95MHz, 100MHz and 105MHz) that a customer can switch from one frequency to another.
- (2) Students who are unable to complete the project design and demonstration within four weeks, will be given an opportunity to complete the project with two weeks extension for 10% reduced points on their own time.

Conclusion

This project in Electronic Communications II creates critical thinking by introducing a design component in the critical part of the project which is the high frequency oscillator circuit to generate the required carrier frequency for modulation. When students understand modulation process and electronic circuits, and have the ability to design a circuit to generate specific high frequencies, and prepare detail project report, and demonstrate PowerPoint presentation and communication skills, then I can say that the students are meeting the course objectives.

Bibliography

- (1) Hoiki, Warren; Laboratory Manual to accompany Telecommunications, 4th ed. Upper Saddle River, NJ; Prentice Hall, 2001.

- (2) Frenzel, E. Louis Jr; Experiments Manual for Principles of Electronic Communication Systems, 3rd ed. McGraw Hill, 2008.
- (3) Schuler, A. Charles; Experiment Manual for Electronics Principles & Applications, 7th ed. McGraw Hill, 2008.
- (4) Paynter, T. Robert; Introductory Electronic Devices and Circuits, 7th ed. Upper Saddle River, NJ; Prentice Hall, 2006.
- (5) Malvino, A., and Bates, D. J. Electronic Principles Experiments Manual, 7th ed. McGraw Hill, 2007.