

Transfer of Knowledge and Skills Assessments in Engineering and Technological Education

Saleh M. Sbenaty
Middle Tennessee State University

I. Introduction

In today's fast changing world, companies spend large amounts of money on staff training and development. To reduce costs and training time, employers are increasingly interested in improving the way employees apply their acquired knowledge and skills to new settings or situations. This is defined as the Transfer of Knowledge and Skills. The current paper describes an assessment method that can be used to measure this transfer of knowledge. It also outlines a practical approach to curriculum development, delivery, and assessment targeted for engineering and technological education. This approach brings real-world problems to the classroom and is hoped to enhance learning and retention in these programs. This method has been applied in technological education in Tennessee and the preliminary results are discussed. The work is done through a three-year NSF-funded grant (\$1.8 million) entitled "The South-East Advanced Technological Education Consortium, SEATEC." The consortium is a collaborative effort of five institutions across Tennessee. Each team includes multi-disciplinary faculties, industry partners, university partners, and high school tech-prep teachers.

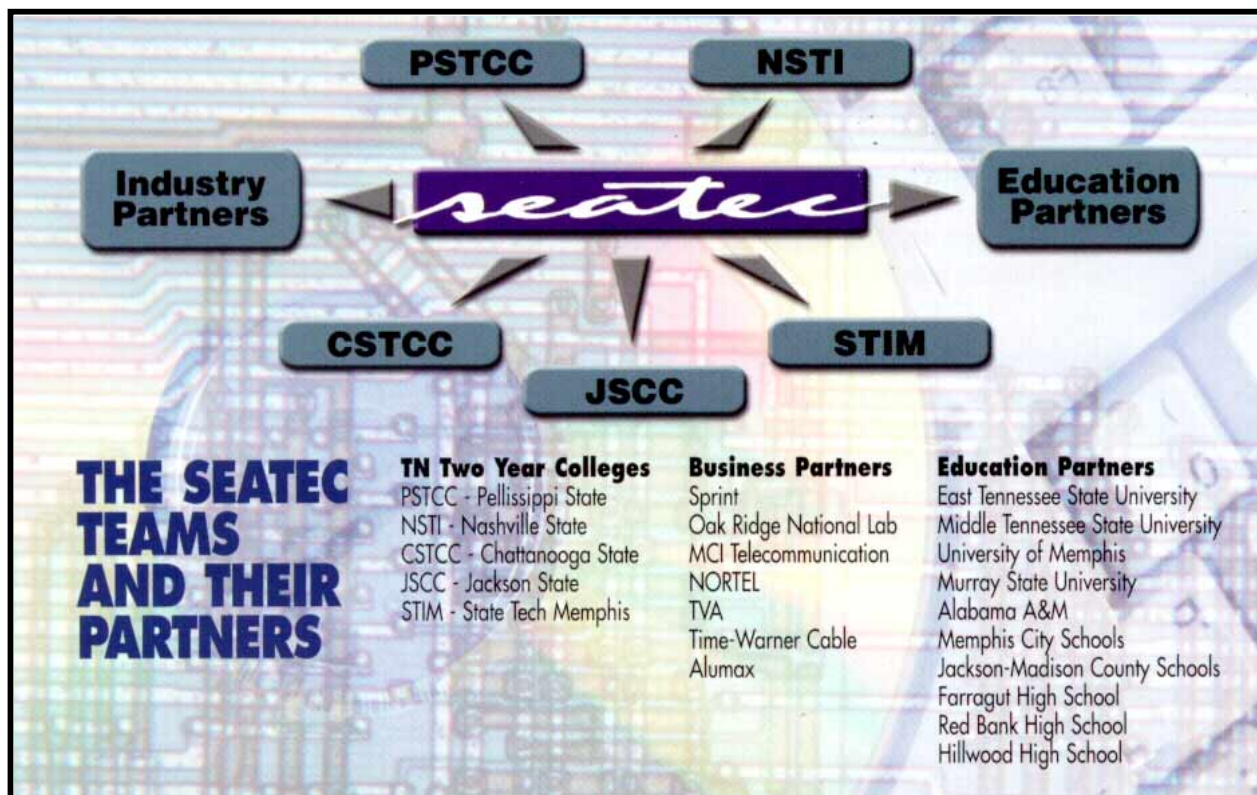

The SEATEC goals are:

1. To provide national leadership for the development and implementation of case-based instruction in technology and engineering education.
2. To provide opportunities for continuous and appropriate professional development of participating faculty.
3. To assess the effectiveness of the case study approach in teaching technology-related curriculum.
4. To nationally disseminate information related to SEATEC activities, materials, and results, including outcomes of the use of case studies in field-test setting.

The current paper focuses on the third goal.

II. Curriculum Development and Delivery Using the Case-Study Approach

Case studies have been proven to be effective teaching tools. They are usually based on real-world problems and allow students to use their critical thinking and logic reasoning abilities. While case studies are traditionally used in the medical and business field, the case method has recently gained acceptance and popularity in engineering and technological education. Students in these programs benefit from exposure to case studies developed by interdisciplinary faculty teams who have identified real-world problems during industry internships and site visits. Although the case method teaches specific technical contents and problem solving skills, it also integrates general educational skills. Collaborative education can be used effectively in a case-study environment. The use of the sciences, mathematics, technical writing, and oral communication knowledge as well as the SCANS 2000 skills can be integrated easily in case studies. Finally, case studies can make classroom learning an enjoyable experience.

One of the greatest challenges that most students face during the course of their higher education is relating classroom topics to real-life situations. Students enrolled in the first circuit analysis course or in college physics, for example, may be engaged in solving series and parallel circuits that are rarely linked to real industry-based problems. In addition, team approach and active learning that attract students with short attention spans are not widely used in technical programs. For this reason, many engineering and technology students often find themselves frustrated and sometimes lose interest in finishing their degrees in such fields. Furthermore, students who earn their degrees face additional challenges in the industry such as working in multi-disciplinary teams, using oral and written communication skills, and dealing with complex and open-ended problems. To address this growing problem, faculties from several institutions across Tennessee, Alabama, and Kentucky are pioneering the development and testing of industry-based case-study approach for the enhancement of engineering and technology education. Models for the development and applications of case studies that are interdisciplinary, multi-media enhanced, open-ended, and use active collaborative learning are being developed, tested and disseminated.

III. Activities to Achieve the SEATEC Objectives

Several activities have taken place to achieve the above set goals, some of which are:

1. Leadership in Case-Based Technical Instruction: The participating faculty had to go through rigorous training and professional development that included workshops and seminars in case study development and implementation; computer based training, team building, active collaborative education, and leadership training; applying multimedia in the classroom; numerous industry site visits and faculty internship in industry; and in applying and field-testing case studies in technology programs.
2. Professional Development: A “Professional Development Team” was formed and conducted campus-wide in-service sessions at the five participating institutions. In addition, numerous industrial site visits exposed the team members to the latest technological practices in the industry and provided the basis for real-world based problems to be used in case studies.
3. Assessment of the Case-Study Approach: Assessment tools for the case method are being developed in cooperation with the Learning Technology Center at Vanderbilt University <http://peabody.vanderbilt.edu/ctrs/ltc/>. Cases are reviewed independently for pedagogical and technical contents and transfer tools are being developed to measure student learning. Each team identified courses where field-testing will be performed and assessments are being conducted. Surveys of faculty and students were conducted before, during, and after testing. Videotaping and outside monitoring were also used. Transfer task tools to assess student learning were developed and used. Technical and pedagogical content reviews by professionals in the field were also conducted. Initial assessments indicate very favorable results.

Several instruments have been implemented to assess the effectiveness of the case method and can be summarized as follows:

- a. Pre and post student surveys: The pre-survey is done after the student briefly read the case and without looking at the case write-up. The post-survey is done after the student finished solving the case also without looking at the case write-up.
- b. Pre and post faculty surveys: Those are done before and after teaching the case.
- c. Interview with both faculty and students.
- d. Transfer Task questions: These questions are designed to measure the student’s retained knowledge gained in the case method and the ability to apply that knowledge in a different problem/situation.

The first fully assessed case was about calculating the resistance of a pizza warmer. The warmer is made of a sheet of conducting material with slits and copper busses. The students were asked later in the semester to calculate the resistance of other non-traditional conducting shapes. The results are compared to those with another section of the same course but without exposure to the case method. Early findings indicate very encouraging results.

4. Dissemination: SEATEC members have published several papers and presented at various international, national, and regional conferences and are disseminating the preliminary results of this grant. A web site has been also created to electronically disseminate materials related to the grant <http://www.nsti.tec.tn.us/SEATEC/>. Videotapes as well as other published materials are also being distributed to interested parties.

IV. Case Components

The initial key components that have been identified by the participating faculty and the team of experts are: A “set”—a brief story line intended to get the reader’s attention and generate interest in the case itself; A background narrative—to provide a historical context and situate the problem in a real-world workplace context; A problem, appropriate for the reader’s situation, and can be small and very specific or larger and more general—this is the issue that the reader must analyze to identify problems and develop solutions; Questions for the student to answer—to promote additional critical thinking and also to guide the analysis that the readers and student groups must conduct; An instructor’s guide—to provide comprehensive support for the teacher through instructional strategies, possible solutions, alternative problems to solve, and tailored support material based upon the content areas and the intended student level of the problem and material contained in the case. The teams agreed to adopt an additional checklist required for the model cases being developed in order to increase quality, consistency, and appropriateness for technology education. These include: student objectives, assessment tools and techniques, “Real-world” business applications, a mathematics component, a science component, technical writing and oral presentation components, a technical focus, identification of target audience, instructor’s guide, suggestions for extending the case, and supporting materials. These model cases are also being further enhanced by the use of multi-media delivery systems.

V. A Sample Case

The author has authored and coauthored several cases one of which is attracting the attention of various educators. It is based on the pizza warmer that the Electrical Product Division of Heatcraft in Murfreesboro, TN has developed. The material being used for the heating element is a revolutionary sheet of plastic impregnated with carbon-composition materials and is called Polytherm™. These sheets come in various thickness and widths. In the circuit analysis track of this case, the student is asked to model the pizza warmer’s electrical circuit and solve for the resistance, current, power, and energy consumption. The case can also take various other tracks such as circuit design, thermodynamics/heat transfer, and/or business applications (engineering economy).

The case is titled “I Want My Pizza Hot” with the following initial student objectives: Model an electrical circuit based on a real electrical load; use critical thinking and apply basic algebra in problem solving; convert between systems of units; calculate the resistance of a material from its physical parameters; apply Ohm’s law in DC circuit analysis; calculate power and energy; conceptualize duty cycle and basic heat transfer; consider electrical safety measures; use spreadsheets, interpret data, and apply charting skills; use software to simulate electrical circuits; use oral and written communications skills to present data and conclusions.

The case includes an Instructor Guide that details a possible approach for conducting the case and helps instructors new to the case method. It also offers solutions to various questions and lists common student misconceptions. The author recommends the use of active collaborative learning for conducting the case. The student is led through the case to a series of events describing the design process of the pizza warmer and then is asked questions that provoke

critical thinking and logic reasoning and to solve the case in cooperation with his/her teammates. The student is also asked to find the resistance the heating element of the warmer. The resistive element has a non-conventional shape (such as cylindrical or block wire) and is shown below. The complete case is available for field-testing and dissemination by contacting SEATEC at <http://www.nsti.tec.tn.us/SEATEC/>.

The pizza warmer heating element is shown in Figure 1 below.

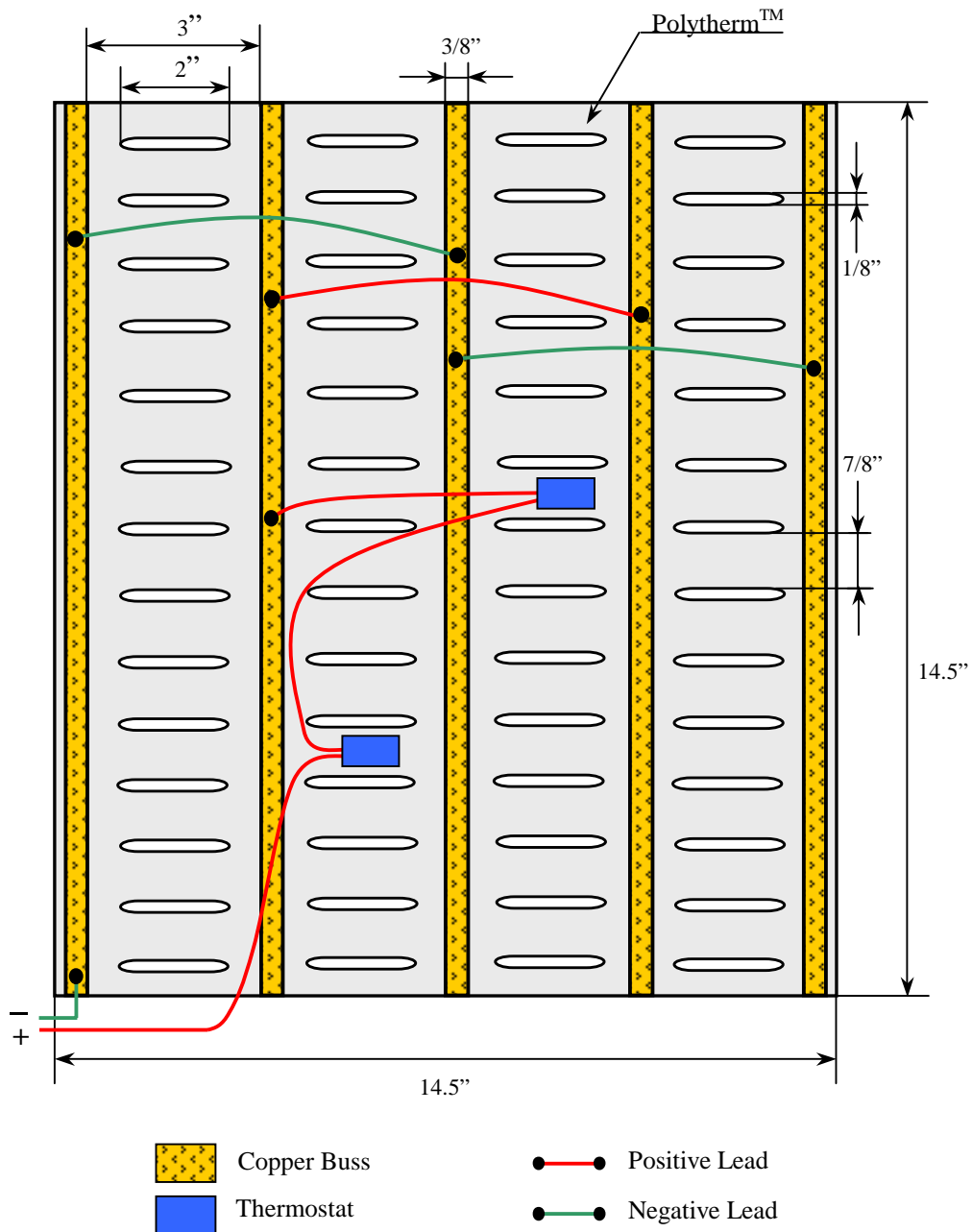

Figure 1. Polytherm™ Pizza Warmer Element

VI. Transfer Task Questions

During the final test, about two months after finishing the case, the students are asked to solve a series of questions to find the resistance of three different shapes: a cylindrical wire (conventional), a block of semiconductor, and a thin carbon-fiber sheet. The questions are distributed throughout the final. These text problems are not accompanied by 3-D figures that may help the student visualize current flow. After finishing this first part and turning it in, a second set of three questions with 3-D figures were given to see if the student can be cued using visual aids as seen in Fig 2-4.

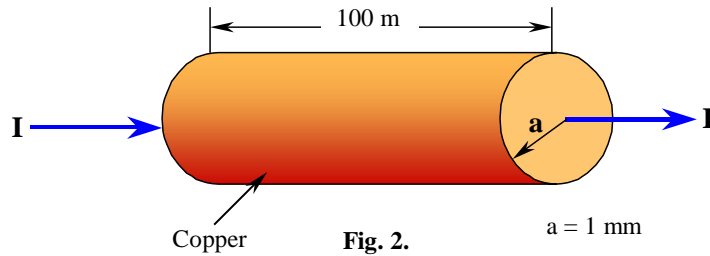

Fig. 2.

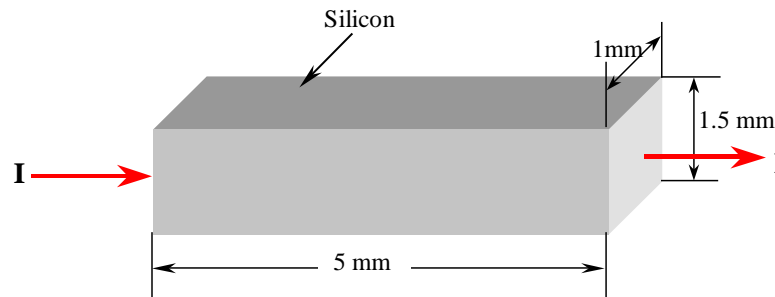

Fig. 3.

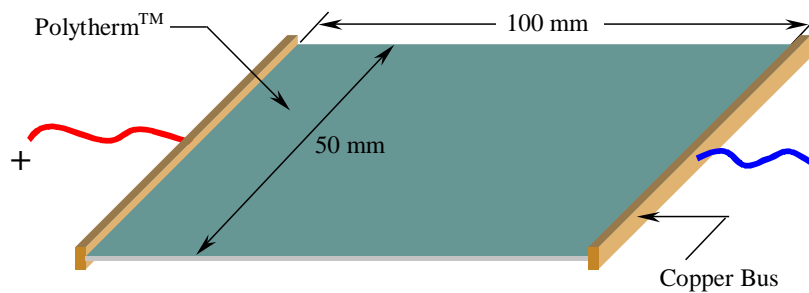

Fig. 4.

The author used a third section of the same class as a control section to compare results. The author taught all sections and covered same materials in the classroom except that cases were not used in the control section. The preliminary results indicate that the case method has helped the students in applying what they have learned using the case to other resistor shapes and forms. This was evident from the way that students answer these questions. It was also evident that the 3-D figures helped the students in all sections to a great extent.

The author is currently working with the TLC center at Vanderbilt to design self-assessment tools that will be imbedded within the case to help the student with self-assessment.

VII. Acknowledgements

The authors wish to express their sincere gratitude to the National Science Foundation for providing the means to execute this project, and to every member of the TEFATE and SEATEC family.

This project was supported, in part, by the National Science Foundation. Opinions expressed are those of the authors and not necessarily those of the Foundation.

SALEH SBENATY

Dr. Saleh M. Sbenaty is currently an Associate Professor of Engineering Technology at Middle Tennessee State University. He received the BS degree in EE from Damascus University, Syria and the MS and Ph.D. degrees in EE from Tennessee Technological University. He is the current team leader of the Nashville Tech. team and actively engaged in curriculum development for technology education. He has written and co-authored several case studies. He is also conducting research in the area of mass spectrometry, power electronics, lasers, and instrumentation.